

Gearmotors General Catalog

INDUCTION GEARMOTORS

- P.31 G/G3 Type Parallel Shaft**
- P.193 H/H2 Type Right Angle Shaft**
- P.307 F Type Right Angle Hollow Bore/Right Angle Shaft**
- P.365 F2/F3 Type Concentric Right Angle Hollow Bore/
Concentric Right Angle Shaft**
- P.463 Technical Documentation**

G/G3 Type

Parallel Shaft

Standard Specification
Model and Type Codes
Standard Model Lineup

P.56	INDUCTION GEARMOTORS
	1. Gearmotors/Gearmotors with Brake
	1-1. Motor Characteristics Table
	1-2. Performance Table
	1-3. Drawings
P.116	2. IP65 Gearmotors / IP65 Gearmotors with Brake
	2-1. Motor Characteristics Table
	2-2. Performance Table
	2-3. Drawings
P.142	3. Gearmotors with Clutch/Brake
	3-1. Motor Characteristics Table
	3-2. Performance Table
	3-3. Drawings
P.152	4. Speed Control Gearmotors
	4-1. Properties and Motor Characteristics Table
	4-2. Graph for Speed Characteristics
	4-3. Performance Table
	4-4. Drawings
P.168	5. Reducers (Double Shaft Type)
	5-1. Performance Table
	5-2. Drawings
P.178	6. S-Type Reducers (Type That Can Be Equipped with Designated Motor)
	6-1. Performance Table
	6-2. Drawings



Standard Specification

G Type Gearmotors/Gearmotors with Brake

Series		MINI		
Motor Unit	Number of Phases	3-Phase	1-Phase	
	Power	15 W to 90 W	15 W to 90 W	
	Power Supply	Standard Voltage	200 V/50 Hz, 200 V/60 Hz, 220 V/60 Hz	Standard Voltage 100 V/50 Hz, 100 V/60 Hz
		High Voltage (400 V Class)	380 V/50 Hz, 400 V/50 Hz, 400 V/60 Hz, 440 V/60 Hz	High Voltage (200 V Class) 200 V/50 Hz, 200 V/60 Hz
	Insulation Class	Ins. B	Ins. B	
	Startup Method	Direct Power Input	Capacitor Run	
	Cooling Method	Totally Enclosed Non-Ventilated (TENV) (IC410) or Totally Enclosed Fan Cooled (TEFC) (IC411)		
	Number of Motor Poles	4		
Rating	Continuous			
Reducer	Reduction Type	Helical Gear		
	Lubrication Type	Grease Lubrication (Maintenance-free)		
	Output Shaft	JIS Key (JIS B 1301-1996 plain form) * The key is included.		
	Output Shaft Material	Carbon Steel		
Case Material	Aluminum Die-cast			
Ambient Conditions	Ambient Temperature	-10 °C to 40 °C		
	Ambient Humidity	85 % max (No Condensation)		
	Altitude	1,000 m max		
	Installation Environment	A place free from corrosive gas, explosive gas, and/or vapor. Well ventilated place with no dust.		
Installation Place	Indoors			
Paint	Paint Color	Gray		
Mounting Direction	No limitations to mounting angle			
Motor Characteristics Table	P.56	P.57		
Performance Table	P.60			
Drawings	P.68			

G/G3 Type
Parallel Shaft

H/H2 Type
Right Angle Shaft

F Type
Right Angle Hollow Bore/
Right Angle Shaft

F2/F3 Type
Concentric Right Angle Hollow Bore/
Concentric Right Angle Shaft

Technical Documentation

G3 Type Gearmotors/Gearmotors with Brake

Series		MID			
Motor Unit	Number of Phases	3-Phase			1-Phase
	Power	0.1 kW to 2.2 kW			0.1 kW to 0.4 kW
	Power Supply	Type	Global Standards Conformance	Power Supply/Frequency	
		Standard Voltage	UL/CE/CCC	200 V/50 Hz, 200 V/60 Hz, 220 V/60 Hz	
		High Voltage (400 V Class)	UL/CE/CCC	380 V/50 Hz, 400 V/50 Hz, 400 V/60 Hz, 440 V/60 Hz	
		Special Voltage	South Korea UL/CE/CCC	220 V/60 Hz, 380 V/60 Hz (Dual Voltage)	
			China/Europe UL/CE/CCC	220 V/50 Hz, 380 V/50 Hz (Dual Voltage)	
			North America/Europe UL/CE/CCC	208 V/60 Hz, 230 V/60 Hz, 460 V/60 Hz (Dual Voltage)	
	North America/Europe UL/CE/CCC	415 V/50 Hz, 440 V/50 Hz, 480 V/60 Hz			
	North America UL	575 V/60 Hz			
Insulation Class	Ins. F			Ins. B	
Startup Method	Direct Power Input			Capacitor Start	
Cooling Method	Totally Enclosed Fan Cooled (TEFC) (IC411) (All of 0.1 kW and 0.2 kW models without brake are totally enclosed non-ventilated (TENV) (IC410))			Totally Enclosed Fan Cooled (TEFC) (IC411) (0.1 kW models without a brake are totally enclosed (TENV) (IC410))	
Number of Motor Poles	4				
Rating	Power	Motor Efficiency	UL/CE Standard	CCC Standard	Continuous
	0.1 kW	IE1	Continuous	Continuous	
	0.2 kW, 0.4 kW (Note 1)	IE2	Continuous	Short Time (120 minutes)	
	0.75 kW or above	IE3, GB3	Continuous	Continuous	
Reducer	Reduction Type	Helical Gear			
	Lubrication Type	Grease Lubrication (Maintenance-free)			
	Output Shaft	JIS Key (JIS B 1301-1996 plain form) * The key is included.			
	Output Shaft Material	Carbon Steel			
	Case Material	Aluminum Die-cast (Frame size 50 is made of cast iron.)			
Ambient Conditions	Ambient Temperature	-10 °C to 40 °C			
	Ambient Humidity	85 % max (No Condensation)			
	Altitude	1,000 m max			
	Installation Environment	A well ventilated place free from corrosive gas, explosive gas, vapor and/or chemicals Not to be exposed to direct rain. Not to be exposed to direct sunlight. The brake should not to be exposed to water, dust, oil/grease, or oil mist. Models with water protection rating IPX0 shall not be exposed directly to water.			
Paint	Paint Color	Gray			
Protective Structure (Note 2)	IP44 or IP40			IP40	
Mounting Direction	No limitations to mounting angle				
Motor Characteristics Table	P.58			P.59	
Performance Table	P.63			P.66	
Drawings	P.68				

Note 1: For CCC Standard, Three-phase 0.2 kW and Three-phase 0.4 kW are certified under limited duty cycle. Please be cautious upon selecting this product.
Note 2: The protective structure differs depending on the model.

G/G3 Type
Parallel Shaft

H/H2 Type
Right Angle Shaft

F Type
Right Angle Hollow Bore/
Right Angle Shaft

F2/F3 Type
Concentric Right Angle Hollow Bore/
Concentric Right Angle Shaft

Technical Documentation

G/G3 Type IP65 Gearmotors/IP65 Gearmotors with Brake

Series		MINI		MID			
Motor Unit	Number of Phases	3-Phase	1-Phase	3-Phase			
	Power	15 W to 90 W	15 W to 60 W	0.1 kW to 2.2 kW			
	Power Supply	Standard Voltage 200 V/50 Hz, 200 V/60 Hz, 220 V/60 Hz	Standard Voltage 100 V/50 Hz, 100 V/60 Hz	Type	Global Standards Conformance	Power Supply/ Frequency	
				Standard Voltage	UL/CE/CCC	200 V/50 Hz, 200 V/60 Hz, 220 V/60 Hz	
				High Voltage (400 V Class)	UL/CE/CCC	380 V/50 Hz, 400 V/50 Hz, 400 V/60 Hz, 440 V/60 Hz	
				Special Voltage	South Korea UL/CE/CCC	220 V/60 Hz, 380 V/60 Hz (Dual Voltage)	
					China/Europe UL/CE/CCC	220 V/50 Hz, 380 V/50 Hz (Dual Voltage) 230 V/50 Hz	
					North America/ Europe UL/CE/CCC	208 V/60 Hz, 230 V/60 Hz, 460 V/60 Hz (Dual Voltage) 400 V/50 Hz	
	North America/ Europe UL/CE/CCC	415 V/50 Hz, 440 V/50 Hz, 480 V/60 Hz					
	North America UL	575 V/60 Hz					
Insulation Class	Ins. B		Ins. F				
Startup Method	Direct Power Input	Capacitor Run	Direct Power Input				
Cooling Method	Totally Enclosed Non-Ventilated (TENV) (IC410)		Totally Enclosed Fan Cooled (TEFC) (IC411) (All of 0.1 kW and 0.2 kW models without brake are totally enclosed non-ventilated (TENV) (IC410))				
Number of Motor Poles	4						
Rating	Continuous		Power	Motor Efficiency	UL/CE Standard	CCC Standard	
			0.1 kW	IE1	Continuous	Continuous	
			0.2 kW, 0.4 kW (Note 1)	IE2	Continuous	Short Time (120 minutes)	
			0.75 kW or above	IE3, GB3	Continuous	Continuous	
Reducer	Reduction Type	Helical Gear					
	Lubrication Type	Grease Lubrication (Maintenance-free)					
	Output Shaft	JIS Key (JIS B 1301-1996 plain form) * The key is included.					
	Output Shaft Material	Stainless Steel	Stainless steel or carbon steel				
	Case Material	Aluminum Die-cast	Aluminum Die-cast (Frame size 50 is made of cast iron.)				
Ambient Conditions	Ambient Temperature	-10 °C to 40 °C					
	Ambient Humidity	100 % max (No Condensation)					
	Altitude	1,000 m max					
	Installation Environment	A place free from corrosive gas, explosive gas, and/or vapor Not to be exposed to strong rain and wind. Not to be exposed to direct sunlight. Not to be used underwater, environments with exposure to high pressure water splashes, and exposure to cleansing chemicals.					
Paint	Paint Color	Gray					
Protective Structure	IP65						
Mounting Direction	No limitations to mounting angle						
Motor Characteristics Table	P.116	P.117					
Performance Table	P.118	P.120					
Drawings	P.123						

Note 1: For CCC Standard, Three-phase 0.2 kW and Three-phase 0.4 kW are certified under limited duty cycle. Please be cautious upon selecting this product.

G3 Type Gearmotors with Clutch/Brake

Series		MID
Motor Unit	Number of Phases	3-Phase
	Power	0.1 kW to 0.75 kW
	Power Supply	Standard Voltage 200 V/50 Hz, 200 V/60 Hz, 220 V/60 Hz
		High Voltage (400 V Class) 380 V/50 Hz, 400 V/50 Hz, 400 V/60 Hz, 440 V/60 Hz
	Insulation Class	Ins. F
	Startup Method	Direct Power Input
	Cooling Method	Totally Enclosed Fan Cooled (TEFC) (IC411) (0.1 kW to 0.2 kW models are totally enclosed non-ventilated. (TENV) (IC410))
	Number of Motor Poles	4
	Rating	Continuous
Reducer	Reduction Type	Helical Gear
	Lubrication Type	Grease Lubrication (Maintenance-free)
	Output Shaft	JIS Key (JIS B 1301-1996 plain form) * The key is included.
	Output Shaft Material	Carbon Steel
	Case Material	Aluminum Die-cast
Ambient Conditions	Ambient Temperature	-10 °C to 40 °C
	Ambient Humidity	85 % max (No Condensation)
	Altitude	1,000 m max
	Installation Environment	A place free from corrosive gas, explosive gas, and/or vapor. Well ventilated place with no dust.
Installation Place	Indoors	
Paint	Paint Color	Gray
Mounting Direction		No limitations to mounting angle
Motor Characteristics		P.142
Performance Table		P.143
Drawings		P.145

G Type Speed Control Gearmotors

Series		MINI
Motor Unit	Number of Phases	1-Phase
	Power	15 W to 90 W
	Power Supply	Standard Voltage 100 V/50 Hz, 100 V/60 Hz
		High Voltage (200 V Class) 200 V/50 Hz, 200 V/60 Hz
	Insulation Class	Ins. B
	Startup Method	Capacitor Run
	Cooling Method	Totally Enclosed Non-Ventilated (TENV) (IC410) (60 to 90 W: provided with a forced fan (TEFC) (IC411))
	Number of Motor Poles	4
	Rating	Continuous
Reducer	Reduction Type	Helical Gear
	Lubrication Type	Grease Lubrication (Maintenance-free)
	Output Shaft	JIS Key (JIS B 1301-1996 plain form) * The key is included.
	Output Shaft Material	Carbon Steel
	Case Material	Aluminum Die-cast
Ambient Conditions	Ambient Temperature	-10 °C to 40 °C
	Ambient Humidity	85 % max (No Condensation)
	Altitude	1,000 m max
	Installation Environment	A place free from corrosive gas, explosive gas, and/or vapor. Well ventilated place with no dust.
Installation Place	Indoors	
Paint	Paint Color	Gray
Mounting Direction		No limitations to mounting angle
Motor Characteristics Table		P.152
Performance Table		P.154
Drawings		P.157

G/G3 Type
Parallel Shaft

H/H2 Type
Right Angle Shaft

F Type
Right Angle Hollow Bore/
Right Angle Shaft

F2/F3 Type
Concentric Right Angle Hollow Bore/
Concentric Right Angle Shaft

Technical Documentation

G3 Type Reducers (Double Shaft Type)

Series		MID
4-Poles Motor Power Class		0.1 kW Class to 2.2 kW Class
Reducer	Reduction Type	Helical Gear
	Lubrication Type	Grease Lubrication (Maintenance-free)
	Output Shaft	JIS Key (JIS B 1301-1996 plain form) * The key is included.
	Input Shaft	JIS Key (JIS B 1301-1996 plain form) * The key is included.
	Output Shaft Material	Carbon Steel
	Input Shaft Material	Carbon Steel
	Case Material	Aluminum Die-cast (Frame size 50 is made of cast iron.)
Ambient Conditions	Ambient Temperature	-10 °C to 40 °C
	Ambient Humidity	85 % max (No Condensation)
	Altitude	1,000 m max
	Installation Environment	A place free from corrosive gas, explosive gas, and/or vapor. Well ventilated place with no dust.
	Installation Place	Indoors
Paint	Paint Color	Gray
Mounting Direction		No limitations to mounting angle
Performance Table		P.168
Drawings		P.170

G3 Type S-Type Reducers

Series		MID
4-Poles Motor Power Class		0.1 kW Class to 2.2 kW Class
Reducer	Reduction Type	Helical Gear
	Lubrication Type	Grease Lubrication (Maintenance-free)
	Output Shaft	JIS Key (JIS B 1301-1996 plain form) * The key is included.
	Output Shaft Material	Carbon Steel
	Case Material	Aluminum Die-cast (Frame size 50 is made of cast iron.)
	Ambient Conditions	Ambient Temperature
Ambient Humidity		85 % max (No Condensation)
Altitude		1,000 m max
Installation Environment		A place free from corrosive gas, explosive gas, and/or vapor. Well ventilated place with no dust.
	Installation Place	Indoors
Paint	Paint Color	Gray
Mounting Direction		No limitations to mounting angle
Performance Table		P.178
Drawings		P.180

G/G3 Type
Parallel Shaft

H/H2 Type
Right Angle Shaft

F Type
Right Angle Hollow Bore/
Right Angle Shaft

F2/F3 Type
Concentric Right Angle Hollow Bore/
Concentric Right Angle Shaft

Technical Documentation

G Type Gearmotors/Gearmotors with Brake MINI Series

Mounting Type	Motor Type	Frame Size	Reduction Ratio	Motor Power	Supply Voltage	Terminal Box	Option	Option Code
GL	M	12	50	T25				
GF	MN	40	1500	S90	W	C	X	T6
①	②	③	④	⑤	⑥	⑦	⑧	⑨

① Mounting Type	GL : Parallel Shaft Foot Mount
	GF : Parallel Shaft Flange Mount
	GK : Parallel Shaft Small Flange Mount (Frame sizes 22 to 32)
② Motor Type	M : With Motor
	MN : With Brakemotor
	MR : Motor with Simple Brake (Option)
③ Frame Size and Output Shaft Diameter	Output Shaft Diameter
④ Reduction Ratio	5: 1/5 to 1800: 1/1800
⑤ Motor Power	T15 : 3-Phase 15 W
	T25 : 3-Phase 25 W
	T40 : 3-Phase 40 W
	T60 : 3-Phase 60 W
	T90 : 3-Phase 90 W
	S15 : 1-Phase 15 W
	S25 : 1-Phase 25 W
	S40 : 1-Phase 40 W
	S60 : 1-Phase 60 W
	S90 : 1-Phase 90 W
⑥ Supply Voltage (High Voltage Option)	Blank : Standard Voltage 3-Phase: 200 V/50 Hz, 200 V/60 Hz, 220 V/60 Hz 1-Phase: 100 V/50 Hz, 100 V/60 Hz
	W : High Voltage 3-Phase: 380 V/50 Hz, 400 V/50 Hz, 400 V/60 Hz, 440 V/60 Hz 1-Phase: 200 V/50 Hz, 200 V/60 Hz
⑦ Terminal Box (Option) (Note 1)	Blank : Flying Leads (Standard Type)
	T : T Type Terminal Box
	K : K Type Terminal Box
	C : Terminal Box with Built-in Rectifier for Gearmotor with Brake (Note 1)
⑧ Option	Blank : Standard Specification
	X : Special Specification Code
⑨ Option Code (Note 2)	Lead Wires/Terminal Box Position Code Please refer to the list of option codes on page 523 for details.

Note 1: When using an inverter for a C type terminal box, be sure to designate an AC switching (A) connection.

Please refer to page 495 for details.

Note 2: The option code will not be shown in the nomenclature on the nameplate. But it will be shown in the Option code row of the nameplate.

G/G3 Type
Parallel Shaft

H/H2 Type
Right Angle Shaft

F Type
Right Angle Hollow Bore/
Right Angle Shaft

F2/F3 Type
Concentric Right Angle Hollow Bore/
Concentric Right Angle Shaft

Technical Documentation

G3 Type Gearmotors/Gearmotors with Brake MID Series [3-Phase]

Gearhead Type				Motor Type								Brake Specifications		Option	
Mounting Type	Frame Size	Shaft Arrangement	Reduction Ratio	Motor Type	Motor Specifications	Motor Power	Number of Phases	Supply Voltage	Standards	Terminal Box	Brake	Option	Option Code		
G3L	18	N	50	M	M	01	T	N	N	T	N				
G3F	32	N	100	M	M	04	T	W	N	E	B4	X	AA		
G3K	32	N	25	M	D	15	T	K	N	T	B2	X	T9HZ		
①	②	③	④	⑤	⑥	⑦	⑧	⑨	⑩	⑪	⑫	⑬	⑭		

① Mounting Type	G3L : Parallel Shaft Foot Mount G3F : Parallel Shaft Flange Mount G3K : Parallel Shaft Small Flange Mount (Frame sizes 18 to 32)	
② Frame Size and Output Shaft Diameter	Output Shaft Diameter	
③ Shaft Arrangement	N : Parallel Shaft	
④ Reduction Ratio	5: 1/5 to 12X: 1/1200	
⑤ Motor Type	M : Standard Induction Motor (IP40 or IP44)	
⑥ Motor Specifications (Note 1)	M : IE1 Efficiency Ins. F (0.1 kW) IE2 Efficiency Ins. F (0.2 kW to 0.4 kW) D : IE3 Efficiency Ins. F (0.75 kW to 2.2 kW)	
⑦ Motor Power	01 : 0.1 kW 02 : 0.2 kW 04 : 0.4 kW 08 : 0.75 kW 15 : 1.5 kW 22 : 2.2 kW	
⑧ Number of Phases	T : 3-Phase	
⑨ Supply Voltage	⑨ Supply Voltage	
	N : 200 V/50 Hz, 200 V/60 Hz, 220 V/60 Hz	⑫ Brake Specifications (Note 2)
	W : 380 V/50 Hz, 400 V/50 Hz, 400 V/60 Hz, 440 V/60 Hz	N B2 B4 J2 J4
	K : 220 V/60 Hz, 380 V/60 Hz	○ ○ ○ ○ ○
	C : 220 V/50 Hz, 230 V/50 Hz, 380 V/50 Hz	○ ○ ○ ○ ○
	A : 208 V/60 Hz, 230 V/60 Hz, 460 V/60 Hz, 400 V/50 Hz	○ ○ ○ ○ ○
	E : 415 V/50 Hz, 440 V/50 Hz, 480 V/60 Hz	○ ○ ○ ○ ○
M : 575 V/60 Hz	○ ○ ○ ○ ○	
⑩ Standards	N : UL/CE/CCC A : UL* Supply Voltage: M (575 V/60 Hz) only	
⑪ Terminal Box (Note 3)	T : T Type Terminal Box (steel plate) (induction motor standard) N : Flying Leads	
⑫ Brake Specifications	N : No Brake B2 : 200 V Class Brake B4 : 400 V Class Brake J2 : 200 V Class Brakemotor with Manual Release J4 : 400 V Class Brakemotor with Manual Release	
	⑬ Option	Blank : Standard Specification X : Special Specification Code
	⑭ Option Code (Note 4)	Built-in Rectifier Connection Code For details, please refer to the list of option codes on page 504.
		Terminal Box Position Code For details, please refer to the list of option codes on page 524.
		For other option codes, please refer to the list of option codes on page 900.

Note 1: For CCC Standard, Three-phase 0.2 kW and Three-phase 0.4 kW are certified under limited duty cycle. Please be cautious upon selecting the product.

Note 2: ○ indicates a brake specification that can be manufactured.

Note 3: With regard to the types of flying leads, only supply voltage codes N and W are covered.

Note 4: The option code will not be shown in the nomenclature on the nameplate. But it will be shown in the Option code row of the nameplate.

G3 Type Gearmotors/Gearmotors with Brake MID Series [1-Phase]

Gearhead Type				Motor Type								Brake Specifications	Option	
Mounting Type	Frame Size	Shaft Arrangement	Reduction Ratio	Motor Type	Motor Specifications	Motor Power	Number of Phases	Supply Voltage	Standards	Terminal Box	Brake	Option	Option Code	
G3L	18	N	50	M	M	01	C	N	J	A	N			
G3F	32	N	450	M	M	02	C	W	J	A	B2			
G3K	28	N	100	M	M	04	C	N	J	A	B2	X	T9HZ	
①	②	③	④	⑤	⑥	⑦	⑧	⑨	⑩	⑪	⑫	⑬	⑭	

① Mounting Type	G3L : Parallel Shaft Foot Mount
	G3F : Parallel Shaft Flange Mount
	G3K : Parallel Shaft Small Flange Mount (Frame sizes 18 to 32)
② Frame Size and Output Shaft Diameter	Output Shaft Diameter
③ Shaft Arrangement	N : Parallel Shaft
④ Reduction Ratio	5: 1/5 to 12X: 1/1200
⑤ Motor Type	M : Standard Induction Motor (IP40)
⑥ Motor Specifications	M : IE1 Efficiency Ins. B
	01 : 0.1 kW
	02 : 0.2 kW
⑦ Motor Power	04 : 0.4 kW
⑧ Number of Phases	C : 1-Phase Capacitor Start
⑨ Supply Voltage (Note 1)	N : 100 V/50 Hz, 100 V/60 Hz
	W : 200 V/50 Hz, 200 V/60 Hz
⑩ Standards	J : No Standards
⑪ Terminal Box	A : A Type Terminal Box (Aluminum)
⑫ Brake Specifications	N : No Brake
	B2 : 200 V Class Brake
⑬ Option	Blank : Standard Specification
	X : Special Specification Code
⑭ Option Code (Note 2)	Terminal Box Position Code Please refer to page 526 for details.

Note 1: For voltages/frequencies not listed above, please contact your nearest Sales Office or the CS Center.

Note 2: The option code will not be shown in the nomenclature on the nameplate. But it will be shown in the Option code row of the nameplate.

G/G3 Type
Parallel Shaft

H/H2 Type
Right Angle Shaft

F Type
Right Angle Hollow Bore/
Right Angle Shaft

F2/F3 Type
Concentric Right Angle Hollow Bore/
Concentric Right Angle Shaft

Technical Documentation

G Type IP65 Gearmotors/IP65 Gearmotors with Brake MINI Series

Mounting Type	Motor Type	Frame Size	Reduction Ratio	Motor Power	Option	Option Code
GL	W	12	50	T25		
GF	V	18	200	T90	X	T6
①	②	③	④	⑤	⑥	⑦

① Mounting Type	GL : Parallel Shaft Foot Mount
	GF : Parallel Shaft Flange Mount
② Motor Type	W : With IP65 Motor (Output Shaft Material: Stainless Steel)
	V : With IP65 Brakemotor (Output Shaft Material: Stainless Steel)
③ Frame Size and Output Shaft Diameter	Output Shaft Diameter
④ Reduction Ratio	5: 1/5 to 240: 1/240
⑤ Motor Power and Supply Voltage/ Frequency	T15 : 3-Phase 15 W
	T25 : 3-Phase 25 W
	T40 : 3-Phase 40 W
	T60 : 3-Phase 60 W
	T90 : 3-Phase 90 W
	S15 : 1-Phase 15 W
	S25 : 1-Phase 25 W
	S40 : 1-Phase 40 W
S60 : 1-Phase 60 W	
⑥ Option	Blank : Standard Specification
	X : Special Specification Code
⑦ Option Code (Note 1)	Cabtyre Cable Position Code Please refer to the list of option codes on page 523 for details.

Note 1: The option code will not be shown in the nomenclature on the nameplate. But it will be shown in the Option code row of the nameplate.

G/G3 Type
Parallel Shaft

H/H2 Type
Right Angle Shaft

F Type
Right Angle Hollow Bore/
Right Angle Shaft

F2/F3 Type
Concentric Right Angle Hollow Bore/
Concentric Right Angle Shaft

Technical Documentation

G3 Type IP65 Gearmotors/IP65 Gearmotors with Brake MID Series

Gearhead Type				Motor Type							Brake Specifications	Option	
Mounting Type	Frame Size	Shaft Arrangement	Reduction Ratio	Motor Type	Motor Specifications	Motor Power	Number of Phases	Supply Voltage	Standards	Terminal Box	Brake	Option	Option Code
G3L	18	N	50	W	M	01	T	N	N	E	N		
G3F	32	S	100	W	M	04	T	W	N	E	V4	X	AA
G3K	32	N	60	W	D	08	T	K	N	E	V2	X	T9HZ
①	②	③	④	⑤	⑥	⑦	⑧	⑨	⑩	⑪	⑫	⑬	⑭

① Mounting Type	G3L : Parallel Shaft Foot Mount G3F : Parallel Shaft Flange Mount G3K : Parallel Shaft Small Flange Mount (Frame sizes 18 to 32)		
② Frame Size and Output Shaft Diameter	Output Shaft Diameter		
③ Shaft Arrangement and Material	Shaft Arrangement		Parallel Shaft
	Material	Carbon Steel Stainless Steel	N S
④ Reduction Ratio	5: 1/5 to 12X: 1/1200		
⑤ Motor Type	W : IP65 Induction Motor		
⑥ Motor Specifications (Note 1)	M : IE1 Efficiency Ins. F (0.1 kW) IE2 Efficiency Ins. F (0.2 kW to 0.4 kW)		
	D : IE3 Efficiency Ins. F (0.75 kW to 2.2 kW)		
⑦ Motor Power	01 : 3-Phase 0.1 kW		
	02 : 3-Phase 0.2 kW		
	04 : 3-Phase 0.4 kW		
	08 : 3-Phase 0.75 kW		
	15 : 3-Phase 1.5 kW		
	22 : 3-Phase 2.2 kW		
⑧ Number of Phases (Note 2)	T : 3-Phase		
⑨ Supply Voltage	⑨ Supply Voltage		⑫ Brake Specifications (Note 3)
			N V2 V4
	N : 200 V/50 Hz, 200 V/60 Hz, 220 V/60 Hz		<input type="radio"/> <input type="radio"/> <input type="radio"/>
	W : 380 V/50 Hz, 400 V/50 Hz, 400 V/60 Hz, 440 V/60 Hz		<input type="radio"/> <input type="radio"/> <input type="radio"/>
	K : 220 V/60 Hz, 380 V/60 Hz		<input type="radio"/> <input type="radio"/> <input type="radio"/>
	C : 220 V/50 Hz, 230 V/50 Hz, 380 V/50 Hz		<input type="radio"/> <input type="radio"/> <input type="radio"/>
	A : 208 V/60 Hz, 230 V/60 Hz, 460 V/60 Hz, 400 V/50 Hz		<input type="radio"/> <input type="radio"/> <input type="radio"/>
	E : 415 V/50 Hz, 440 V/50 Hz, 480 V/60 Hz		<input type="radio"/> <input type="radio"/> <input type="radio"/>
⑩ Standards	M : 575 V/60 Hz		
	N : UL/CE/CCC A : UL* Supply Voltage: M (575 V/60 Hz) only		
⑪ Terminal Box	E : E Type Terminal Box (Aluminum)		
⑫ Brake Specifications (Note 5)	N : No Brake		
	V2 : IP65 200 V Class Brake (Note 4)		
	V4 : IP65 400 V Class Brake (Note 4)		
⑬ Option	Blank : Standard Specification		
	X : Special Specification Code		
⑭ Option Code (Note 6)	Built-in Rectifier Connection Code For details, please refer to the list of option codes on page 504.		
	Terminal Box Position Code For details, please refer to the list of option codes on page 524.		
	For other option codes, please refer to the list of option codes on page 900.		

Note 1: For CCC Standard, Three-phase 0.2 kW and Three-phase 0.4 kW are certified under limited duty cycle. Please be cautious upon selecting the product.

Note 2: Single-phase types are not available.

Note 3: indicates a brake specification that can be manufactured.

Note 4: IP65 gearmotors with a brake are not available for 1.5 kW and 2.2 kW.

Note 5: The rectifier is included with the product.

Note 6: The option code will not be shown in the nomenclature on the nameplate. But it will be shown in the Option code row of the nameplate.

G/G3 Type
Parallel Shaft

H/H2 Type
Right Angle Shaft

F Type
Right Angle Hollow Bore/
Right Angle Shaft

F2/F3 Type
Concentric Right Angle Hollow Bore/
Concentric Right Angle Shaft

Technical Documentation

G3 Type Gearmotors with Clutch/Brake MID Series

Gearhead Type				Motor Type								Brake Specifications	Option	
Mounting Type	Frame Size	Shaft Arrangement	Reduction Ratio	Motor Type	Motor Specifications	Motor Power	Number of Phases	Supply Voltage	Standards	Terminal Box	Brake	Option	Option Code	
G3L	18	N	25	E	M	02	T	N	J	T	N			
G3F	22	N	80	E	M	04	T	W	J	T	N			
G3K	32	N	100	E	D	08	T	W	J	T	N	X	T9HZ	
①	②	③	④	⑤	⑥	⑦	⑧	⑨	⑩	⑪	⑫	⑬	⑭	

① Mounting Type	G3L : Parallel Shaft Foot Mount
	G3F : Parallel Shaft Flange Mount
	G3K : Parallel Shaft Small Flange Mount (Frame sizes 18 to 32)
② Frame Size and Output Shaft Diameter	Output Shaft Diameter
③ Shaft Arrangement	N : Parallel Shaft
④ Reduction Ratio	5: 1/5 to 200: 1/200
⑤ Motor Type	E : Induction Motor With Clutch/Brake
⑥ Motor Specifications	M : IE1 Efficiency Ins. F (0.1 kW) IE2 Efficiency Ins. F (0.2 kW to 0.4 kW)
	D : IE3 Efficiency Ins. F
⑦ Motor Power	01 : 0.1 kW
	02 : 0.2 kW
	04 : 0.4 kW
	08 : 0.75 kW
⑧ Number of Phases	T : 3-Phase
⑨ Supply Voltage (Note 1)	N : 200 V/50 Hz, 200 V/60 Hz, 220 V/60 Hz
	W : 380 V/50 Hz, 400 V/50 Hz, 400 V/60 Hz, 440 V/60 Hz
⑩ Standards	J : No Standards
⑪ Terminal Box	T : T Type Terminal Box (Steel Plate)
⑫ Brake Specifications	N : No Brake (With Clutch/Brake)
⑬ Option	Blank : Standard Specification
	X : Special Specification Code
⑭ Option Code (Note 2)	Terminal Box Position Code Please refer to page 526 for details.

Note 1: For voltages/frequencies not listed above, please contact your nearest Sales Office or the CS Center.

Note 2: The option code will not be shown in the nomenclature on the nameplate. But it will be shown in the Option code row of the nameplate.

Note 3: Please avoid using gearmotors with clutch/brake in vertical operation (lifting). There is a danger of falling during a power outage.

G Type Speed Control Gearmotors MINI Series

Mounting Type	Motor Type	Frame Size	Reduction Ratio	Motor Power	Supply Voltage	Terminal Box	Option	Option Code
GL	U	12	50	S25				
GF	P	40	1500	S90	W	C	X	T6
①	②	③	④	⑤	⑥	⑦	⑧	⑨

① Mounting Type	GL	: Parallel Shaft Foot Mount
	GF	: Parallel Shaft Flange Mount
	GK	: Parallel Shaft Small Flange Mount (Frame sizes 22 to 32)
② Motor Type	U	: U Type with Speed Control Motor (Controller Set)
	P	: P Type with Speed Control Motor (Controller: Sold Separately)
③ Frame Size and Output Shaft Diameter	Output Shaft Diameter	
④ Reduction Ratio	5: 1/5 to 1800: 1/1800	
⑤ Motor Power	S15	: 1-Phase 15 W
	S25	: 1-Phase 25 W
	S40	: 1-Phase 40 W
	S60	: 1-Phase 60 W
	S90	: 1-Phase 90 W
⑥ Supply Voltage (High Voltage Option)	Blank	: Standard Voltage 1-Phase: 100 V/50 Hz, 100 V/60 Hz
	W	: High Voltage (200 V Class) 1-Phase: 200 V/50 Hz, 200 V/60 Hz
⑦ Terminal Box (Option) (Note 1)	Blank	: Flying Leads (Standard Type)
	C	: Terminal Box for P Type Speed Controller
⑧ Option	Blank	: Standard Specification
	X	: Special Specification Code
⑨ Option Code (Note 2)	Lead Wires/Terminal Box Position Code Please refer to the list of option codes on page 523 for details.	

Note 1: Please refer to page 579 for the specifications of terminal boxes.

Note 2: The option code will not be shown in the nomenclature on the nameplate. But it will be shown in the Option code row of the nameplate.

Controller

Type Code

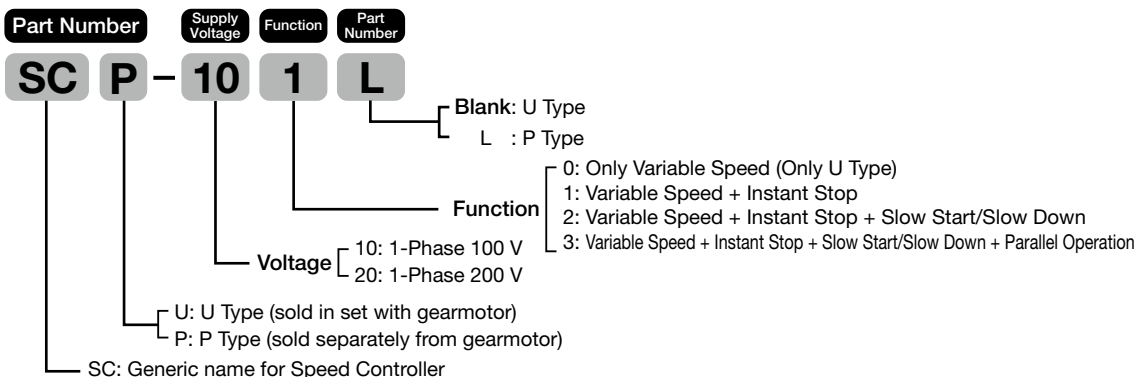

G/G3 Type Parallel Shaft

H/H2 Type Right Angle Shaft

F Type Right Angle Hollow Bore/Right Angle Shaft

F2/F3 Type Concentric Right Angle Hollow Bore/Concentric Right Angle Shaft

Technical Documentation

G3 Type Reducers (Double Shaft Type) MID Series

Mounting Type	Motor Type	Frame Size	Reduction Ratio	Motor Power Class	Option	Terminal Box	Option	Option Code
G3L		22	50	020				
G3F		40	200	075			X	
①	②	③	④	⑤	⑥	⑦	⑧	⑨

① Mounting Type	G3L : Parallel Shaft Foot Mount
	G3F : Parallel Shaft Flange Mount
	G3K : Parallel Shaft Small Flange Mount (Frame sizes 18 to 32)
② Motor Type	Blank : Without Motor (Double Shaft Type)
③ Frame Size and Output Shaft Diameter	Output Shaft Diameter
④ Reduction Ratio	5: 1/5 to 1200: 1/1200
⑤ Motor Power Class	010 : 0.1 kW Class
	020 : 0.2 kW Class
	040 : 0.4 kW Class
	075 : 0.75 kW Class
	150 : 1.5 kW Class
	220 : 2.2 kW Class
⑥ Option	Blank : Standard Specification There is no applicable option.
⑦ Terminal Box	Blank : Standard Specification
⑧ Option	Blank : Standard Specification
	X : Special Specification Code
⑨ Option Code (Note 1)	Blank : Standard Specification

Note 1: The option code will not be shown in the nomenclature on the nameplate. But it will be shown in the Option code row of the nameplate.

G3 Type S-Type Reducers MID Series

Mounting Type	Motor Type	Frame Size	Reduction Ratio	Motor Power Class	Option	Terminal Box	Option
G3L	S	22	50	020			
G3F	S	40	200	075			X
①	②	③	④	⑤	⑥	⑦	⑧

① Mounting Type	G3L : Parallel Shaft Foot Mount
	G3F : Parallel Shaft Flange Mount
	G3K : Parallel Shaft Small Flange Mount (Frame sizes 18 to 32)
② Motor Type	S : Type That Can be Equipped with Designated Motor (S-Type)
③ Frame Size and Output Shaft Diameter	Output Shaft Diameter
④ Reduction Ratio	5: 1/5 to 1200: 1/1200
⑤ Motor Power Class	010 : 0.1 kW Class
	020 : 0.2 kW Class
	040 : 0.4 kW Class
	075 : 0.75 kW Class
	150 : 1.5 kW Class
220 : 2.2 kW Class	
⑥ Option	Blank : Standard Specification
⑦ Terminal Box	Blank : Standard Specification
⑧ Option	Blank : Standard Specification
	X : Special Specification Code

G/G3 Type
Parallel Shaft

H/H2 Type
Right Angle Shaft

F Type
Right Angle Hollow Bore/
Right Angle Shaft

F2/F3 Type
Concentric Right Angle Hollow Bore/
Concentric Right Angle Shaft

Technical Documentation

Standard Model Lineup

G Type Gearmotors/Gearmotors with Brake MINI Series

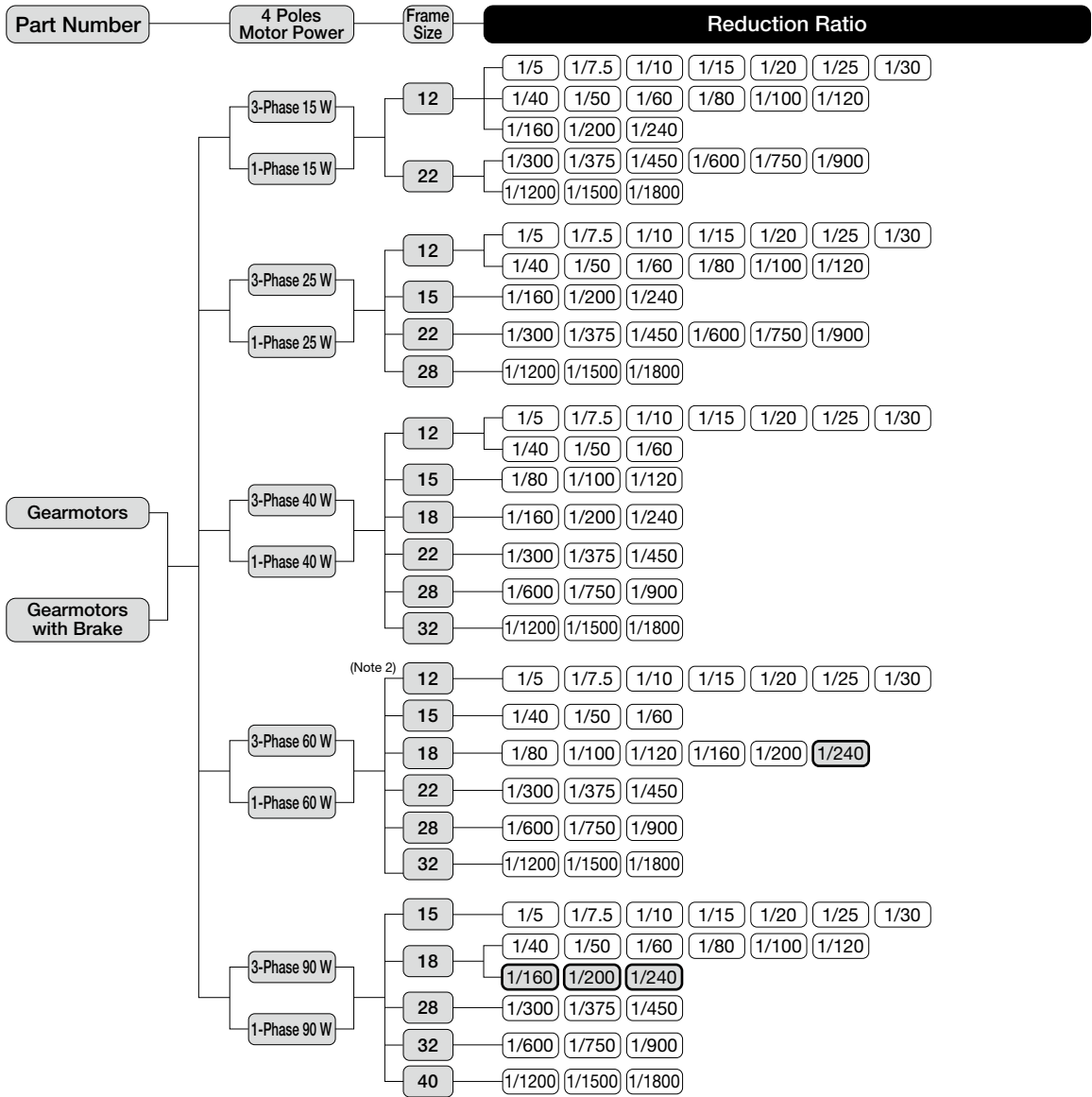

Note 1: Please note that mounting type GK is available only for frame sizes 22 to 32.
 Note 2: The frame size for types other than Three-phase standard voltage types is 15. The frame size for all Single-phase types is 15.
 Note 3: indicates a limited torque type. Please make sure to check the allowable output shaft torque in the performance table.

G3 Type Gearmotors/Gearmotors with Brake MID Series

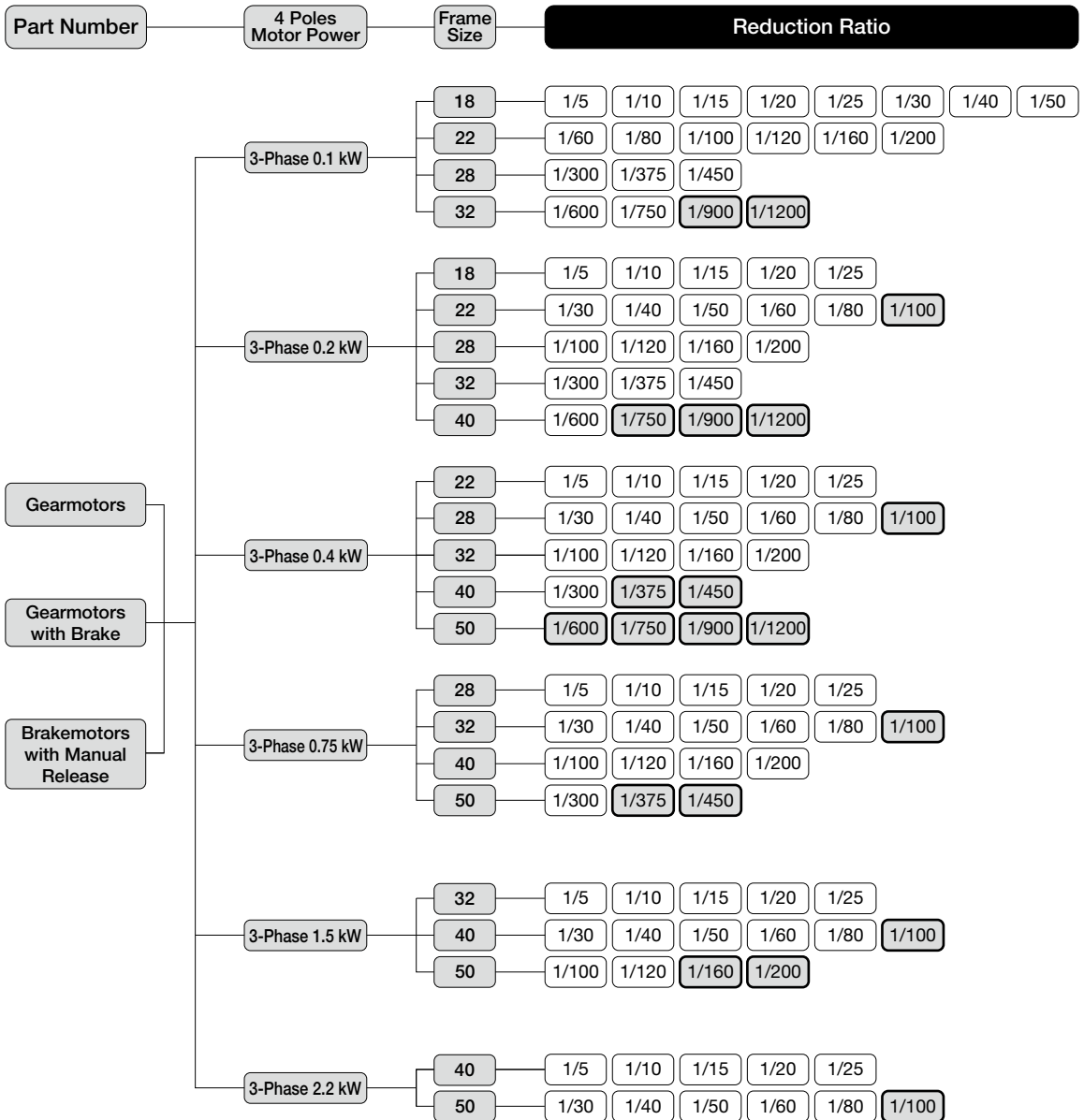

Note 1: The G3 Type is available in three types: Foot mount, Flange mount, and Small flange mount.

Please note that mounting type G3K is available only for frame sizes 18 to 32.

Note 2: indicates a limited torque type. Please make sure to check the allowable output shaft torque in the performance table.

G/G3 Type
Parallel Shaft

H/H2 Type
Right Angle Shaft

F Type
Right Angle Hollow Bore/
Right Angle Shaft

F2/F3 Type
Concentric Right Angle Hollow Bore/
Concentric Right Angle Shaft

Technical Documentation

G3 Type Gearmotors/Gearmotors with Brake MID Series

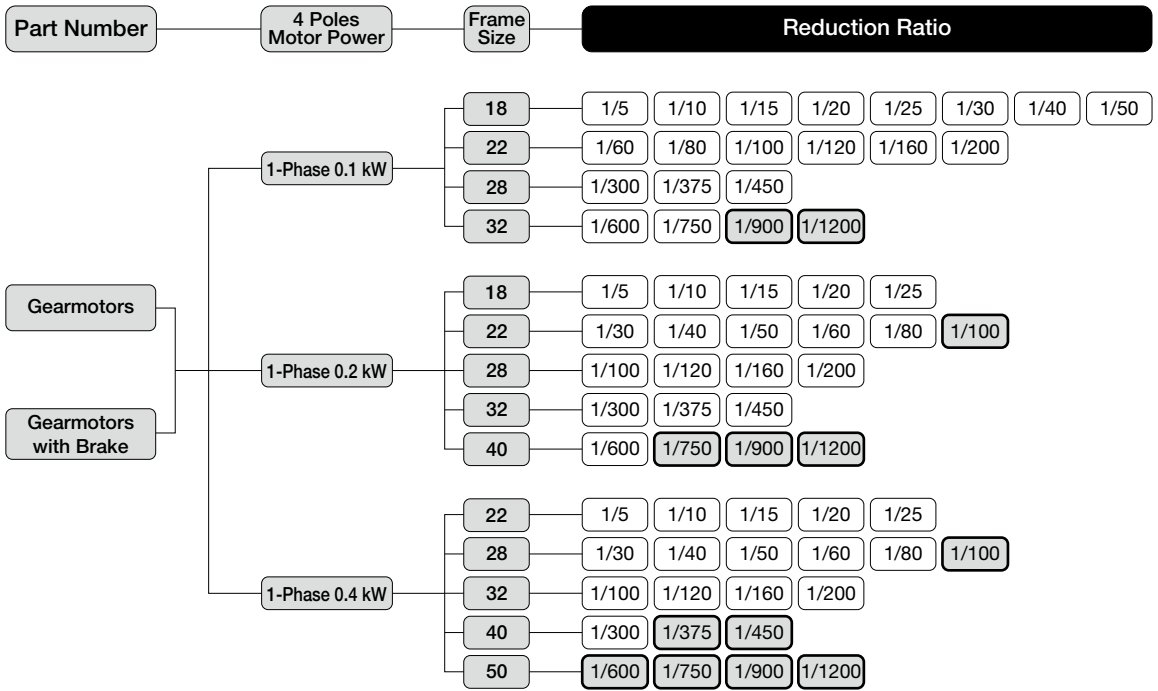

Note 1: The G3 Type is available in three types: Foot mount, Flange mount, and Small flange mount.

Please note that mounting type G3K is available only for frame sizes 18 to 32.

Note 2: indicates a limited torque type. Please make sure to check the allowable output shaft torque in the performance table.

G Type IP65 Gearmotors/IP65 Gearmotors with Brake MINI Series

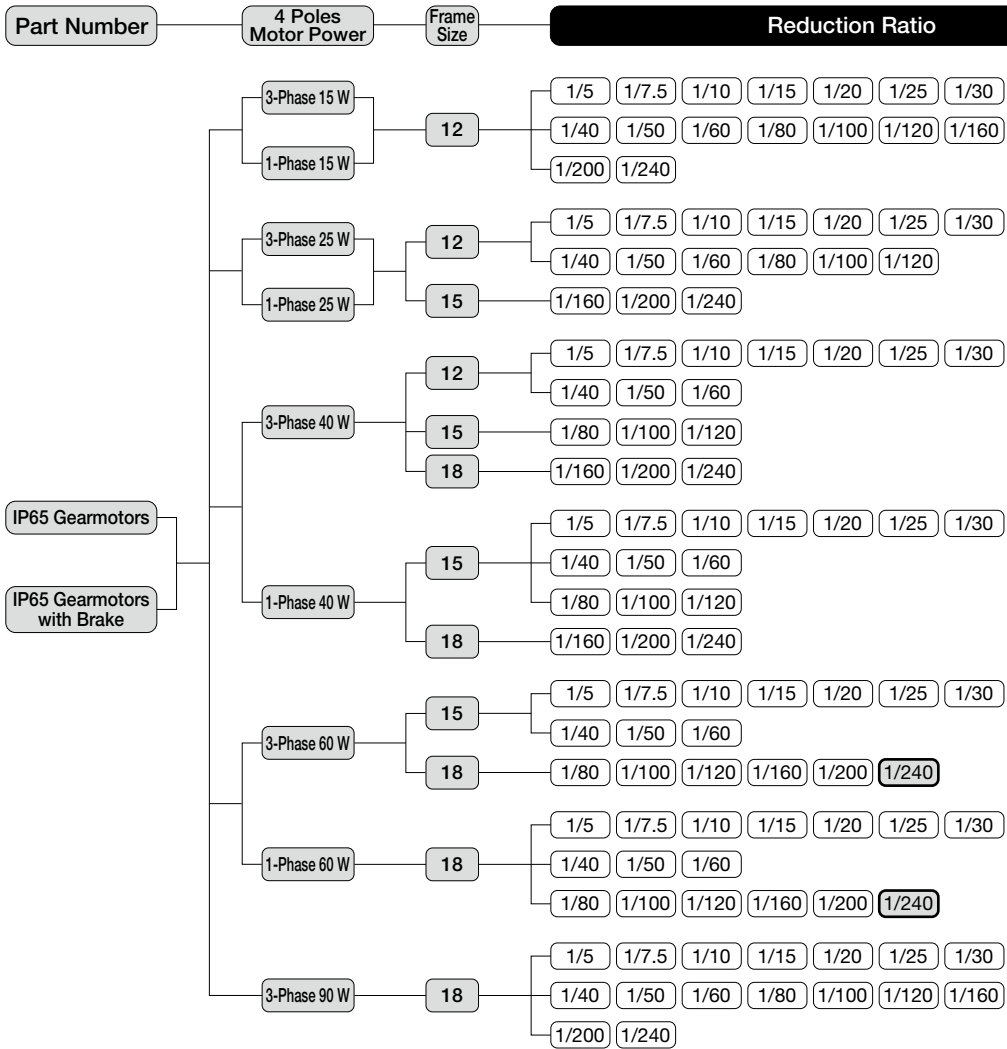

Note 1: Single-phase types are not available.

Note 2: indicates a limited torque type. Please make sure to check the allowable output shaft torque in the performance table.

G/G3 Type
Parallel Shaft

H/H2 Type
Right Angle Shaft

F Type
Right Angle Hollow Bore/
Right Angle Shaft

F2/F3 Type
Concentric Right Angle Hollow Bore/
Concentric Right Angle Shaft

Technical Documentation

G3 Type IP65 Gearmotors/IP65 Gearmotors with Brake MID Series

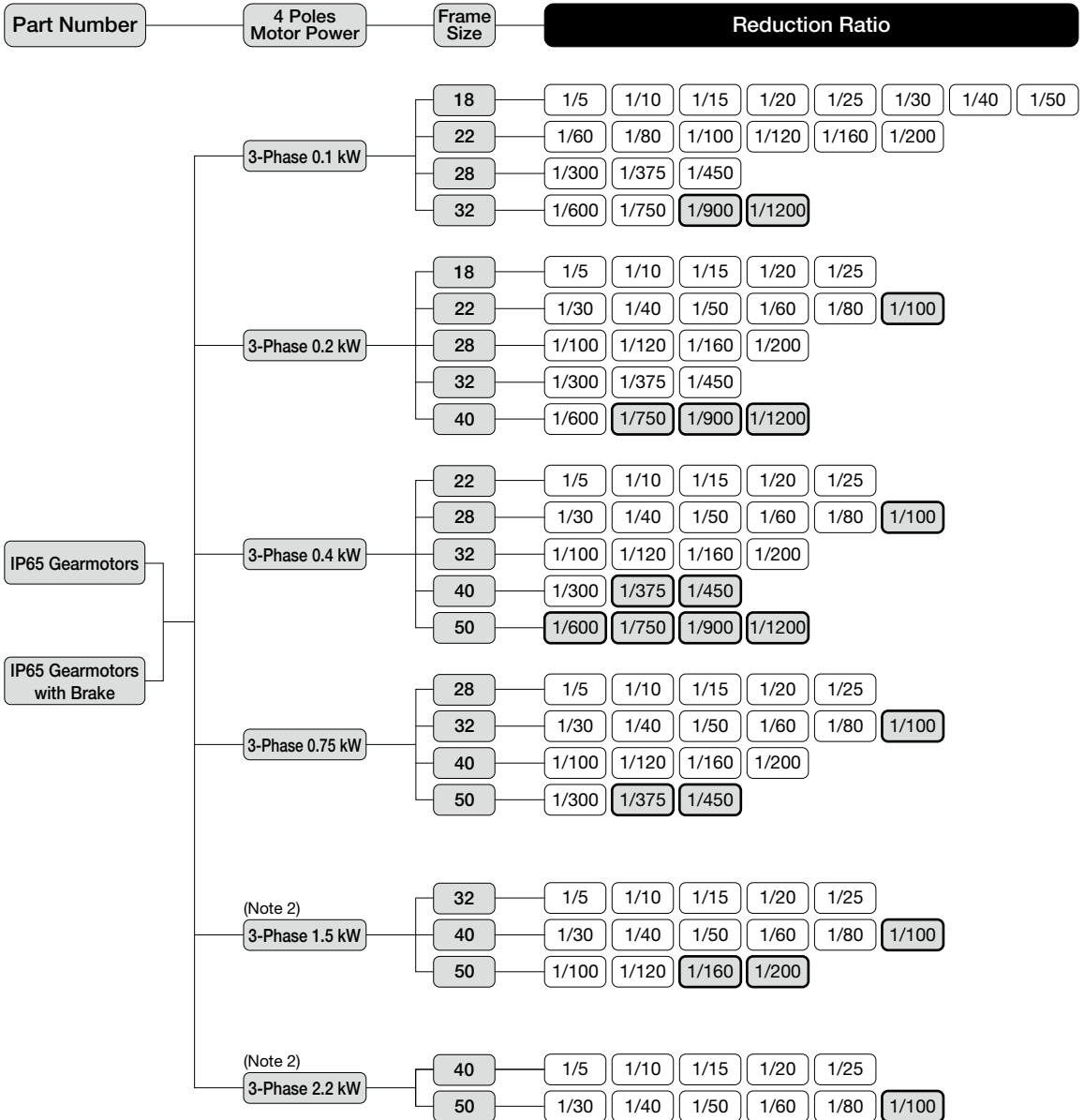

Note 1: The G3 Type is available in three types: Foot mount, Flange mount, and Small flange mount.

Please note that mounting type G3K is available only for frame sizes 18 to 32.

Note 2: IP65 gearmotors with a brake are not available with motor powers of 1.5 kW and 2.2 kW.

Note 3: indicates a limited torque type. Please make sure to check the allowable output shaft torque in the performance table.

G3 Type Gearmotors with Clutch/Brake MID Series

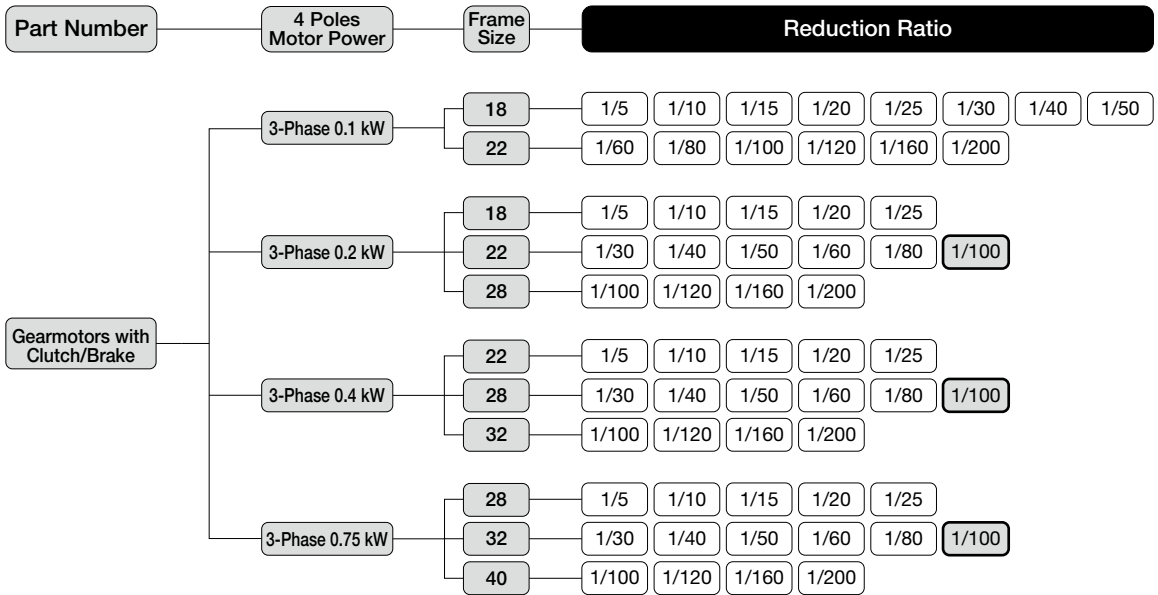

Note 1: The G3 Type is available in three types: Foot mount, Flange mount, and Small flange mount.

Please note that mounting type G3K is available only for frame sizes 18 to 32.

Note 2: **[Thick border]** indicates a limited torque type. Please make sure to check the allowable output shaft torque in the performance table.

G/G3 Type
Parallel Shaft

H/H2 Type
Right Angle Shaft

F Type
Right Angle Hollow Bore/
Right Angle Shaft

F2/F3 Type
Concentric Right Angle Hollow Bore/
Concentric Right Angle Shaft

Technical Documentation

G Type Speed Control Gearmotors MINI Series

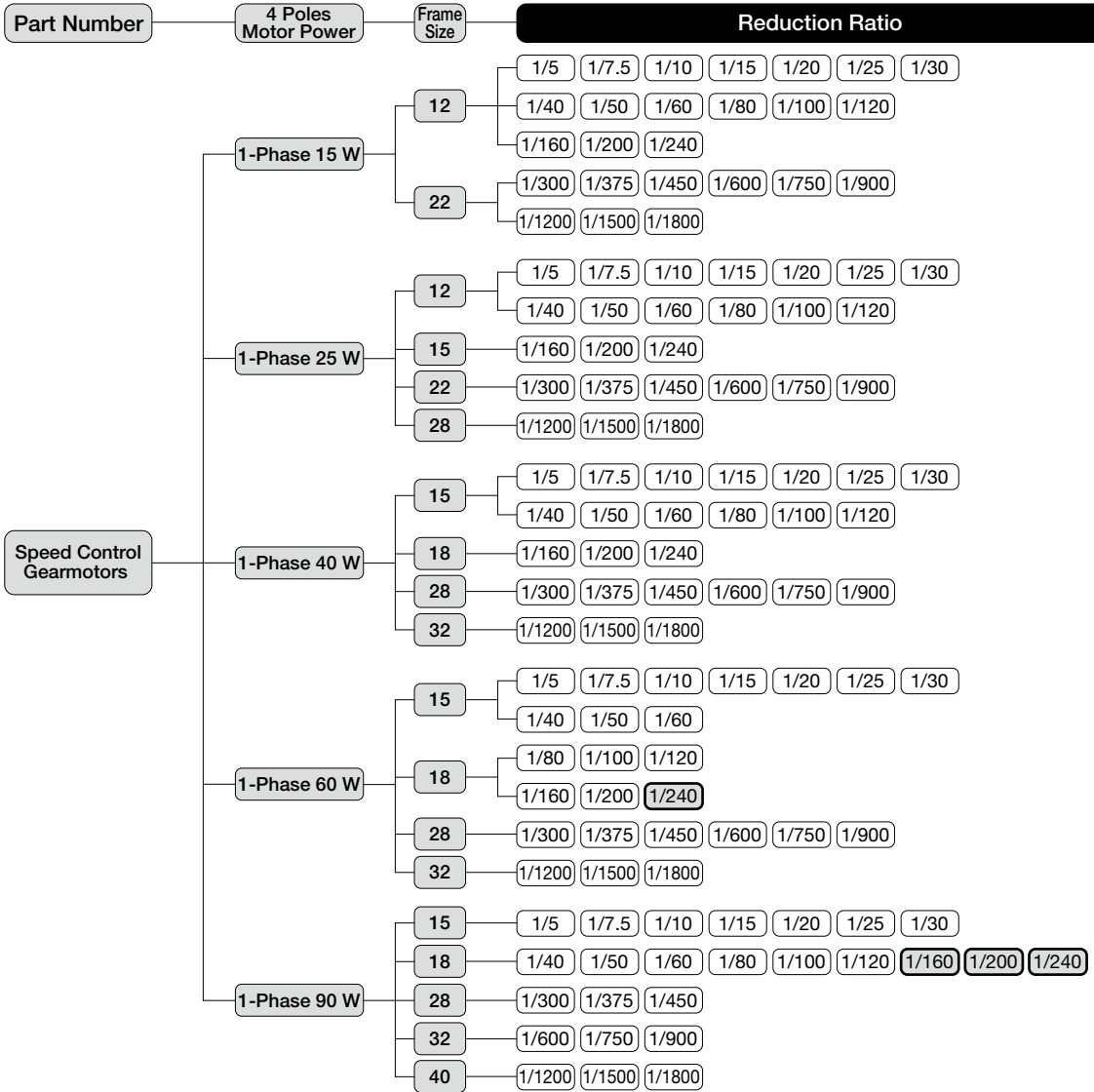

Note 1: Please note that mounting type GK is available only for frame sizes 22 to 32.

Note 2: indicates a limited torque type. Please make sure to check the allowable output shaft torque in the performance table.

G/G3 Type
Parallel Shaft

H/H2 Type
Right Angle Shaft

F Type
Right Angle Hollow Bore/
Right Angle Shaft

F2/F3 Type
Concentric Right Angle Hollow Bore/
Concentric Right Angle Shaft

Technical Documentation

G3 Type Reducers (Double Shaft Type) MID Series

Part Number	Motor Power Class	Frame Size	Reduction Ratio									
Reducers (Double Shaft Type)	0.1 kW	18	1/5	1/10	1/15	1/20	1/25	1/30	1/40	1/50		
		22	1/60	1/80	1/100	1/120	1/160	1/200				
		28	1/300	1/375	1/450							
		32	1/600	1/750	1/900	1/1200						
	0.2 kW	18	1/5	1/10	1/15	1/20	1/25					
		22	1/30	1/40	1/50	1/60	1/80	1/100				
		28	1/100	1/120	1/160	1/200						
		32	1/300	1/375	1/450							
		40	1/600	1/750	1/900	1/1200						
	0.4 kW	22	1/5	1/10	1/15	1/20	1/25					
		28	1/30	1/40	1/50	1/60	1/80	1/100				
		32	1/100	1/120	1/160	1/200						
		40	1/300	1/375	1/450							
		50	1/600	1/750	1/900	1/1200						
	0.75 kW	28	1/5	1/10	1/15	1/20	1/25					
		32	1/30	1/40	1/50	1/60	1/80	1/100				
		40	1/100	1/120	1/160	1/200						
		50	1/300	1/375	1/450							
	1.5 kW	32	1/5	1/10	1/15	1/20	1/25					
		40	1/30	1/40	1/50	1/60	1/80	1/100				
		50	1/100	1/120	1/160	1/200						
	2.2 kW	40	1/5	1/10	1/15	1/20	1/25					
		50	1/30	1/40	1/50	1/60	1/80	1/100				

Note 1: The G3 Type is available in three types: Foot mount, Flange mount, and Small flange mount.

Please note that mounting type G3K is available only for frame sizes 18 to 32.

Note 2: indicates a limited torque type. Please make sure to check the allowable output shaft torque in the performance table.

G/G3 Type
Parallel Shaft

H/H2 Type
Right Angle Shaft

F Type
Right Angle Hollow Bore/
Right Angle Shaft

F2/F3 Type
Concentric Right Angle Hollow Bore/
Concentric Right Angle Shaft

Technical Documentation

G3 Type S-Type Reducers MID Series

Part Number	Motor Power Class	Frame Size	Reduction Ratio													
S-Type Reducers	0.1 kW	18	1/5	1/10	1/15	1/20	1/25	1/30	1/40	1/50						
		22	1/60	1/80	1/100	1/120	1/160	1/200								
		28	1/300	1/375	1/450											
		32	1/600	1/750	1/900	1/1200										
	0.2 kW	18	1/5	1/10	1/15	1/20	1/25									
		22	1/30	1/40	1/50	1/60	1/80	1/100								
		28	1/100	1/120	1/160	1/200										
		32	1/300	1/375	1/450											
		40	1/600	1/750	1/900	1/1200										
	0.4 kW	22	1/5	1/10	1/15	1/20	1/25									
		28	1/30	1/40	1/50	1/60	1/80	1/100								
		32	1/100	1/120	1/160	1/200										
		40	1/300	1/375	1/450											
		50	1/600	1/750	1/900	1/1200										
	0.75 kW	28	1/5	1/10	1/15	1/20	1/25									
		32	1/30	1/40	1/50	1/60	1/80	1/100								
		40	1/100	1/120	1/160	1/200										
		50	1/300	1/375	1/450											
	1.5 kW	32	1/5	1/10	1/15	1/20	1/25									
		40	1/30	1/40	1/50	1/60	1/80	1/100								
		50	1/100	1/120	1/160	1/200										
	2.2 kW	40	1/5	1/10	1/15	1/20	1/25									
		50	1/30	1/40	1/50	1/60	1/80	1/100								

Note 1: The G3 Type is available in three types: Foot mount, Flange mount, and Small flange mount.

Please note that mounting type G3K is available only for frame sizes 18 to 32.

Note 2: indicates a limited torque type. Please make sure to check the allowable output shaft torque in the performance table.

MEMO

Technical Documentation	F2/F3 Type Concentric Right-Angle Hollow Bore/ Concentric Right Angle Shaft	F Type Right-Angle Hollow Bore/ Right Angle Shaft	H/H2 Type Right Angle Shaft	G/G3 Type Parallel Shaft
-------------------------	---	---	--------------------------------	-----------------------------

1. Gearmotors Gearmotors with Brake

1-1. Motor Characteristics Table

G Type 3-Phase Standard Voltage

Series	Power (W)	Voltage (V)	Frequency (Hz)	Frame Size	Rated Current (A)	Rated Speed (r/min)	Startup Current (A)
MINI	15	200/200/220	50/60/60	12	0.14/0.13/0.13	1350/1550/1600	0.30/0.28/0.31
				22	0.14/0.13/0.13	1350/1550/1600	0.30/0.28/0.31
	25	200/200/220	50/60/60	12	0.21/0.19/0.19	1350/1550/1600	0.44/0.42/0.46
				15	0.18/0.17/0.17	1350/1550/1600	0.43/0.41/0.46
				22	0.21/0.19/0.19	1350/1550/1600	0.44/0.42/0.46
				28	0.18/0.17/0.17	1350/1550/1600	0.43/0.41/0.46
	40	200/200/220	50/60/60	12	0.29/0.27/0.27	1350/1550/1600	0.67/0.62/0.68
				15	0.27/0.26/0.26	1350/1550/1550	0.73/0.69/0.76
				18	0.21/0.21/0.21	1350/1550/1600	0.66/0.64/0.70
				22	0.29/0.27/0.27	1350/1550/1600	0.67/0.62/0.68
				28	0.27/0.26/0.26	1350/1550/1550	0.73/0.69/0.76
				32	0.27/0.26/0.26	1350/1550/1550	0.73/0.69/0.76
	60	200/200/220	50/60/60	12	0.42/0.39/0.39	1350/1550/1550	0.94/0.86/1.00
				15	0.40/0.36/0.36	1350/1550/1600	1.04/0.97/1.07
				18	0.33/0.33/0.33	1350/1550/1600	1.06/1.01/1.11
				22	0.42/0.39/0.39	1350/1550/1550	0.94/0.86/1.00
				28	0.40/0.36/0.36	1350/1550/1600	1.04/0.97/1.07
				32	0.40/0.36/0.36	1350/1550/1600	1.04/0.97/1.07
	90	200/200/220	50/60/60	15	0.51/0.48/0.48	1350/1550/1550	1.42/1.36/1.49
				18	0.47/0.47/0.47	1350/1550/1600	1.59/1.51/1.66
				28	0.51/0.48/0.48	1350/1550/1550	1.42/1.36/1.49
				32	0.51/0.48/0.48	1350/1550/1550	1.42/1.36/1.49
				40	0.47/0.47/0.47	1350/1550/1600	1.59/1.51/1.66
				40	0.47/0.47/0.47	1350/1550/1600	1.59/1.51/1.66

G Type 3-Phase High Voltage (400 V Class)

Series	Power (W)	Voltage (V)	Frequency (Hz)	Frame Size	Rated Current (A)	Rated Speed (r/min)	Startup Current (A)
MINI	15	380/400/400/440	50/50/60/60	12	0.11/0.12/0.10/0.11	1400/1400/1700/1700	0.26/0.28/0.26/0.29
				22	0.11/0.12/0.10/0.11	1400/1400/1700/1700	0.26/0.28/0.26/0.29
	25	380/400/400/440	50/50/60/60	12	0.11/0.12/0.11/0.12	1350/1400/1600/1650	0.26/0.28/0.26/0.29
				15	0.09/0.09/0.09/0.09	1300/1350/1550/1600	0.20/0.21/0.20/0.22
				22	0.11/0.12/0.11/0.12	1350/1400/1600/1650	0.26/0.28/0.26/0.29
				28	0.09/0.09/0.09/0.09	1300/1350/1550/1600	0.20/0.21/0.20/0.22
	40	380/400/400/440	50/50/60/60	12	0.14/0.14/0.14/0.14	1300/1350/1550/1600	0.30/0.32/0.30/0.33
				15	0.13/0.14/0.13/0.14	1300/1350/1550/1600	0.33/0.35/0.33/0.37
				18	0.10/0.10/0.10/0.10	1350/1400/1600/1650	0.31/0.34/0.32/0.35
				22	0.14/0.14/0.14/0.14	1300/1350/1550/1600	0.30/0.32/0.30/0.33
				28	0.13/0.14/0.13/0.14	1300/1350/1550/1600	0.33/0.35/0.33/0.37
				32	0.13/0.14/0.13/0.14	1300/1350/1550/1600	0.33/0.35/0.33/0.37
	60	380/400/400/440	50/50/60/60	15	0.17/0.17/0.17/0.17	1300/1350/1550/1600	0.43/0.45/0.43/0.47
				18	0.16/0.16/0.16/0.16	1350/1400/1600/1650	0.48/0.51/0.49/0.54
				22	0.20/0.20/0.20/0.20	1250/1300/1500/1550	0.38/0.40/0.38/0.41
				28	0.17/0.17/0.17/0.17	1300/1350/1550/1600	0.43/0.45/0.43/0.47
				32	0.17/0.17/0.17/0.17	1300/1350/1550/1600	0.43/0.45/0.43/0.47
				40	0.26/0.26/0.26/0.26	1300/1350/1550/1600	0.70/0.74/0.69/0.77
	90	380/400/400/440	50/50/60/60	18	0.23/0.23/0.24/0.24	1350/1350/1600/1650	0.73/0.78/0.74/0.81
				28	0.26/0.26/0.26/0.26	1300/1350/1550/1600	0.70/0.74/0.69/0.77
				32	0.26/0.26/0.26/0.26	1300/1350/1550/1600	0.70/0.74/0.69/0.77
				40	0.23/0.23/0.24/0.24	1350/1350/1600/1650	0.73/0.78/0.74/0.81
				40	0.23/0.23/0.24/0.24	1350/1350/1600/1650	0.73/0.78/0.74/0.81
				40	0.23/0.23/0.24/0.24	1350/1350/1600/1650	0.73/0.78/0.74/0.81

The rated current in the motor characteristics table is the current data for the motor operating without a gearbox.

With regard to gearmotors with a brake, it is necessary to consider the current value flowing through the brake as needed.

For more details, please contact your nearest Sales Office or the CS Center.

1-1. Motor Characteristics Table

G Type 1-Phase Standard Voltage

Series	Power (W)	Voltage (V)	Frequency (Hz)	Frame Size	Rated Current (A)	Rated Speed (r/min)	Startup Current (A)	Capacitor (μF)
MINI	15	100/100	50/60	12	0.39/0.35	1350/1650	0.72/0.67	5
				22	0.39/0.35	1350/1650	0.72/0.67	5
	25	100/100	50/60	12	0.48/0.48	1350/1600	0.86/0.80	7
				15	0.44/0.45	1350/1650	1.00/0.92	7
				22	0.48/0.48	1350/1600	0.86/0.80	7
				28	0.44/0.45	1350/1650	1.00/0.92	7
	40	100/100	50/60	12	0.67/0.80	1400/1650	1.26/1.23	12
				15	0.61/0.66	1350/1650	1.43/1.36	10
				18	0.63/0.64	1400/1650	2.16/2.00	10
				22	0.67/0.80	1400/1650	1.26/1.23	12
				28	0.61/0.66	1350/1650	1.43/1.36	10
				32	0.61/0.66	1350/1650	1.43/1.36	10
	60	100/100	50/60	15	0.90/1.00	1350/1600	2.11/1.98	15
				18	0.90/1.00	1400/1650	2.55/2.37	15
				22	0.90/1.10	1300/1500	1.33/1.34	15
				28	0.90/1.00	1350/1600	2.11/1.98	15
	90	100/100	50/60	32	0.90/1.00	1350/1600	2.11/1.98	15
				15	1.30/1.40	1350/1600	2.89/2.68	20
				18	1.20/1.40	1350/1600	3.27/3.04	20
				28	1.30/1.40	1350/1600	2.89/2.68	20
32				1.30/1.40	1350/1600	2.89/2.68	20	
40	1.20/1.40	1350/1600	3.27/3.04	20				

G/G3 Type
Parallel Shaft

H/H2 Type
Right Angle Shaft

F Type
Right Angle Hollow Bore/
Right Angle Shaft

G Type 1-Phase High Voltage (200 V Class)

Series	Power (W)	Voltage (V)	Frequency (Hz)	Frame Size	Rated Current (A)	Rated Speed (r/min)	Startup Current (A)	Capacitor (μF)
MINI	15	200/200	50/60	12	0.21/0.19	1350/1650	0.35/0.33	1.2
				22	0.21/0.19	1350/1650	0.35/0.33	1.2
	25	200/200	50/60	12	0.26/0.25	1350/1600	0.47/0.44	1.7
				15	0.23/0.24	1350/1650	0.46/0.45	1.7
				22	0.26/0.25	1350/1600	0.47/0.44	1.7
				28	0.23/0.24	1350/1650	0.46/0.45	1.7
	40	200/200	50/60	12	0.34/0.33	1350/1600	0.66/0.60	2.5
				15	0.29/0.34	1350/1600	0.64/0.61	2.5
				18	0.31/0.32	1400/1650	0.98/0.92	2.5
				22	0.34/0.33	1350/1600	0.66/0.60	2.5
				28	0.29/0.34	1350/1600	0.64/0.61	2.5
				32	0.29/0.34	1350/1600	0.64/0.61	2.5
	60	200/200	50/60	15	0.45/0.48	1350/1600	1.06/1.00	3.5
				18	0.42/0.45	1400/1650	1.29/1.22	3.5
				22	0.43/0.50	1300/1500	0.67/0.64	3.5
				28	0.45/0.48	1350/1600	1.06/1.00	3.5
	90	200/200	50/60	32	0.45/0.48	1350/1600	1.06/1.00	3.5
				15	0.65/0.66	1350/1600	1.44/1.35	5
				18	0.59/0.65	1400/1650	1.67/1.58	5
				28	0.65/0.66	1350/1600	1.44/1.35	5
32				0.65/0.66	1350/1600	1.44/1.35	5	
40	0.59/0.65	1400/1650	1.67/1.58	5				

F2/F3 Type
Concentric Right Angle Hollow Bore/
Concentric Right Angle Shaft

Technical Documentation

The rated current in the motor characteristics table is the current data for the motor operating without a gearbox. With regard to gearmotors with a brake, it is necessary to consider the current value flowing through the brake as needed. For more details, please contact your nearest Sales Office or the CS Center.

G Type 3-Phase Standard Voltage/High Voltage (400 V Class)/Special Voltage

Series	Power	Power Supply/ Certification Codes	Voltage (V)	Frequency (Hz)	Rated Current (A)	Startup Current (A)	Rated Speed (r/min)
MID	0.1 kW	NN	200/200/220	50/60/60	0.61/0.54/0.54	2.39/2.27/2.52	1410/1690/1710
		WN	380/400/400/440	50/50/60/60	0.31/0.31/0.28/0.28	1.12/1.18/1.12/1.22	1400/1410/1690/1720
		KN	220/380	60/60	0.52/0.30	1.90/1.10	1680/1680
		CN	220/230/380	50/50/50	0.55/0.54/0.31	1.94/2.03/1.12	1400/1410/1400
		AN	208/230/460/400	60/60/60/50	0.54/0.57/0.29/0.31	2.35/2.62/1.26/1.21	1690/1730/1730/1410
		EN	415/440/480	50/50/60	0.30/0.29/0.26	1.06/1.12/1.17	1390/1420/1720
	MA	575	60	0.20	0.87	1700	
	0.2 kW IE2	NN	200/200/220	50/60/60	1.1/1.0/1.0	4.70/4.35/4.85	1400/1680/1700
		WN	380/400/400/440	50/50/60/60	0.56/0.56/0.50/0.50	2.29/2.38/2.29/2.48	1390/1400/1680/1710
		KN	220/380	60/60	0.93/0.52	3.70/2.20	1680/1680
		CN	220/230/380	50/50/50	0.99/0.98/0.56	3.97/4.15/2.29	1400/1410/1390
		AN	208/230/460/400	60/60/60/50	1.0/1.0/0.50/0.56	4.78/5.16/2.56/2.44	1680/1720/1720/1400
		EN	415/440/480	50/50/60	0.50/0.50/0.45	1.75/1.86/2.00	1370/1400/1700
	MA	575	60	0.40	1.78	1710	
	0.4 kW IE2	NN	200/200/220	50/60/60	2.1/1.8/1.8	9.50/8.60/9.60	1400/1680/1700
		WN	380/400/400/440	50/50/60/60	1.0/1.0/0.9/0.9	4.35/4.65/4.30/4.75	1390/1400/1680/1710
		KN	220/380	60/60	1.7/1.0	7.10/4.00	1670/1670
		CN	220/230/380	50/50/50	1.8/1.8/1.0	7.53/7.88/4.35	1390/1400/1390
		AN	208/230/460/400	60/60/60/50	1.8/1.8/0.9/1.0	8.90/9.76/4.73/4.78	1680/1720/1720/1400
		EN	415/440/480	50/50/60	0.96/0.95/0.82	3.96/4.20/4.20	1390/1410/1680
	MA	575	60	0.68	3.51	1700	
	0.75 kW IE3	NN	200/200/220	50/60/60	3.2/3.0/2.9	19.1/16.6/18.6	1440/1720/1740
		WN	380/400/400/440	50/50/60/60	1.65/1.60/1.50/1.40	9.00/9.60/8.30/9.30	1430/1440/1730/1740
		KN	220/380	60/60	2.8/1.6	17.9/10.8	1750/1750
CN		220/230/380	50/50/50	2.8/2.7/1.65	15.6/16.3/9.00	1430/1440/1430	
AN		208/230/460/400	60/60/60/50	2.9/2.8/1.4/1.6	18.3/19.6/10.2/10.0	1740/1750/1750/1440	
EN		415/440/480	50/50/60	1.50/1.50/1.35	9.1/9.65/9.70	1440/1450/1750	
MA	575	60	1.10	6.60	1750		
1.5 kW IE3	NN	200/200/220	50/60/60	6.4/6.0/5.7	43.5/36.0/40.3	1450/1740/1750	
	WN	380/400/400/440	50/50/60/60	3.3/3.2/3.0/2.9	21.7/23.1/18.6/20.7	1440/1450/1740/1750	
	KN	220/380	60/60	5.6/3.2	43.2/24.3	1760/1760	
	CN	220/230/380	50/50/50	5.6/5.6/3.3	37.6/39.3/21.7	1450/1460/1440	
	AN	208/230/460/400	60/60/60/50	5.9/5.7/2.9/3.2	42.3/45.3/23.0/24.3	1750/1760/1760/1450	
	EN	415/440/480	50/50/60	3.0/3.0/2.7	19.8/21.0/18.5	1460/1470/1760	
MA	575	60	2.2	15.3	1760		
2.2 kW IE3	NN	200/200/220	50/60/60	8.8/8.4/7.9	58.5/47.0/52.5	1450/1740/1750	
	WN	380/400/400/440	50/50/60/60	4.5/4.4/4.2/3.9	30.0/32.0/25.0/28.0	1440/1450/1740/1750	
	KN	220/380	60/60	7.8/4.5	56.4/32.3	1760/1760	
	CN	220/230/380	50/50/50	7.9/7.7/4.5	52.0/54.3/30.0	1460/1470/1440	
	AN	208/230/460/400	60/60/60/50	8.3/7.9/4.0/4.5	60.8/65.2/34.8/36.3	1750/1770/1770/1470	
	EN	415/440/480	50/50/60	4.3/4.3/3.8	33.1/35.5/29.8	1460/1470/1770	
MA	575	60	3.3	24.4	1760		

The rated current in the motor characteristics table is the current data for the motor operating without a gearbox. With regard to gearmotors with a brake, it is necessary to consider the current value flowing through the brake as needed. For more details, please contact your nearest Sales Office or the CS Center.

G/G3 Type
Parallel Shaft

H/H2 Type
Right Angle Shaft

F Type
Right Angle Hollow Bore/
Right Angle Shaft

F2/F3 Type
Concentric Right Angle Hollow Bore/
Concentric Right Angle Shaft

Technical Documentation

1-1. Motor Characteristics Table

G3 Type 1-Phase Standard Voltage

Series	Power	Startup Method	Voltage (V)	Frequency (Hz)	Rated Current (A)	Startup Current (A)	Rated Speed (r/min)	Startup Torque (%)	Breakdown Torque (%)
MID	0.1 kW	Capacitor Start	100/100	50/60	2.7/2.4	10.5/10.5	1420/1710	220/204	188/184
	0.2 kW	Capacitor Start	100/100	50/60	5.1/4.5	20.0/20.0	1420/1700	276/294	194/187
	0.4 kW	Capacitor Start	100/100	50/60	8.7/7.9	32.0/32.0	1440/1730	210/205	189/178

The rated current in the motor characteristics table is the current data for the motor operating without a gearbox.
 With regard to gearmotors with a brake, it is necessary to consider the current value flowing through the brake as needed.
 For more details, please contact your nearest Sales Office or the CS Center.

G3 Type 1-Phase High Voltage (200 V Class)

Series	Power	Startup Method	Voltage (V)	Frequency (Hz)	Rated Current (A)	Startup Current (A)	Rated Speed (r/min)	Startup Torque (%)	Breakdown Torque (%)
MID	0.1 kW	Capacitor Start	200/200	50/60	1.3/1.2	5.4/5.4	1420/1710	222/200	194/182
	0.2 kW	Capacitor Start	200/200	50/60	2.5/2.2	10.0/10.0	1420/1700	254/250	203/205
	0.4 kW	Capacitor Start	200/200	50/60	4.3/3.9	19.0/18.9	1440/1730	181/190	240/217

The rated current in the motor characteristics table is the current data for the motor operating without a gearbox.
 With regard to gearmotors with a brake, it is necessary to consider the current value flowing through the brake as needed.
 For more details, please contact your nearest Sales Office or the CS Center.

G/G3 Type
Parallel Shaft

H/H2 Type
Right Angle Shaft

F Type
Right Angle Hollow Bore/
Right Angle Shaft

F2/F3 Type
Concentric Right Angle Hollow Bore/
Concentric Right Angle Shaft

Technical Documentation

1-2. Performance Table

G Type Gearmotors/Gearmotors with Brake

[Notes]

- The output shaft speed is the value relative to the synchronous speed of the motor and the reduction ratio.
- Allowable output shaft O.H.L. is the value at the middle of the output shaft.
- In the performance table, the reduction ratio in indicates that when the connection is made as shown on page 492 (CW), the direction of rotation is clockwise in the case of a three-phase motor or counterclockwise in the case of a single-phase motor when viewed from the output shaft side. (Refer to the figure on the right)
- The “*” mark indicates a limited torque type. Please make sure to check the allowable output shaft torque in the performance table.

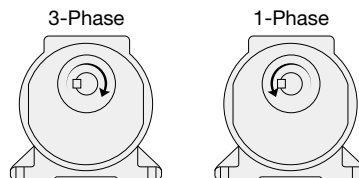

G/G3 Type
Parallel Shaft

H/H2 Type
Right Angle Shaft

F Type
Right Angle Hollow Bore/
Right Angle Shaft

F2/F3 Type
Concentric Right Angle Hollow Bore/
Concentric Right Angle Shaft

Technical Documentation

Series	Motor Power	Frame Size	Reduction Ratio	Actual Reduction Ratio	Output Shaft Speed		Allowable Output Shaft Torque	Allowable Output Shaft O.H.L.	Drawings		
					r/min				Foot Mount	Flange Mount	Small Flange Mount
					50 Hz	60 Hz	N·m	N			
MINI	15 W	12	1/5	1/5	300	360	0.29	98	P.68	P.87	-
			1/7.5	1/7.5	200	240	0.49	196			
			1/10	1/10	150	180	0.69	245			
			1/15	1/15	100	120	0.98	343			
			1/20	1/20	75	90	1.27	441			
			1/25	1/25	60	72	1.67	490			
			1/30	1/29	50	60	1.96	539			
			1/40	1/40	37.5	45	2.65	588			
			1/50	1/50	30	36	3.33	637			
			1/60	1/58	25	30	3.92	686			
			1/80	1/80	18.8	22.5	5.00	735			
			1/100	1/100	15	18	6.27	735			
		1/120	1/120	12.5	15	7.45	784				
		1/160	1/160	9.4	11.2	9.80	784				
		1/200	1/200	7.5	9	12.7	784				
		1/240	1/232	6.3	7.5	14.7	784				
		1/300	91/27000	5	6	16.7	1760				
		1/375	11/4050	4	4.8	20.6	1760				
		1/450	637/297000	3.3	4	25.5	1760				
		1/600	91/54000	2.5	3	33.3	1760				
		1/750	11/8100	2	2.4	42.1	1760				
		1/900	637/594000	1.7	2	50.0	1760				
		1/1200	91/104400	1.3	1.5	66.6	1760				
		1/1500	11/15660	1	1.2	83.3	1760				
	1/1800	637/1148400	0.8	1	98.0	1760					
	1/5	1/5	300	360	0.59	98					
	1/7.5	1/7.5	200	240	0.78	196					
	1/10	1/10	150	180	1.08	245					
	1/15	1/15	100	120	1.67	343					
	1/20	1/20	75	90	2.25	441					
	1/25	1/25	60	72	2.74	490					
	1/30	1/29	50	60	3.33	539					
	1/40	1/40	37.5	45	4.41	588					
	1/50	1/50	30	36	5.49	637					
	1/60	1/58	25	30	6.66	686					
	1/80	1/80	18.8	22.5	8.43	735					
	1/100	1/100	15	18	10.8	735					
	1/120	1/120	12.5	15	12.7	784					
	1/160	1/160	9.4	11.2	16.7	1080					
	1/200	1/200	7.5	9	20.6	1080					
	1/240	1/232	6.3	7.5	25.5	1080					
	1/300	91/27000	5	6	28.4	1760					
	1/375	11/4050	4	4.8	35.3	1760					
	1/450	637/297000	3.3	4	42.1	1760					
	1/600	91/54000	2.5	3	55.9	1760					
	1/750	11/8100	2	2.4	69.6	1760					
	1/900	637/594000	1.7	2	84.3	1760					
	1/1200	221/249690	1.3	1.5	108	2740					
1/1500	187/261870	1	1.2	137	2740						
1/1800	169/285360	0.8	1	167	2740						

1-2. Performance Table

Series	Motor Power	Frame Size	Reduction Ratio	Actual Reduction Ratio	Output Shaft Speed		Allowable Output Shaft Torque	Allowable Output Shaft O.H.L.	Drawings		
					r/min				Foot Mount	Flange Mount	Small Flange Mount
					50 Hz	60 Hz	N·m	N			
MINI	40 W	12	1/5	1/5	300	360	0.88	98	P.68	P.87	-
			1/7.5	1/7.5	200	240	1.37	196			
			1/10	1/10	150	180	1.76	245			
			1/15	1/15	100	120	2.65	343			
			1/20	1/20	75	90	3.53	441			
			1/25	1/25	60	72	4.41	490			
			1/30	1/29	50	60	5.29	539			
			1/40	1/40	37.5	45	7.06	588			
			1/50	1/50	30	36	8.82	637			
		1/60	1/58	25	30	10.8	686				
		1/80	1/80	18.8	22.5	13.7	980				
		1/100	1/100	15	18	16.7	980				
		1/120	1/120	12.5	15	20.6	1080				
		1/160	1/160	9.4	11.2	26.5	1370				
		1/200	1/200	7.5	9	33.3	1370				
		1/240	1/240	6.3	7.5	40.2	1370				
		1/300	91/27000	5	6	45.1	1760				
		1/375	11/4050	4	4.8	55.9	1760				
		1/450	637/297000	3.3	4	67.6	1760				
		1/600	221/129150	2.5	3	90.2	2740				
		1/750	187/135450	2	2.4	118	2740				
		1/900	169/147600	1.7	2	137	2740				
		1/1200	13/14964	1.3	1.5	176	5100				
		1/1500	11/15660	1	1.2	225	5100				
		1/1800	13/22446	0.8	1	274	5100				
		1/5	1/5	300	360	1.37	98				
		1/7.5	1/7.5	200	240	2.06	196				
		1/10	1/10	150	180	2.74	245				
		1/15	1/15	100	120	4.12	343				
		1/20	1/20	75	90	5.49	441				
		1/25	1/25	60	72	6.96	490				
		1/30	1/29	50	60	8.33	539				
		1/5	1/5	300	360	1.37	98				
		1/7.5	1/7.5	200	240	2.06	196				
		1/10	1/10	150	180	2.74	245				
		1/15	1/15	100	120	4.12	343				
	1/20	1/20	75	90	5.49	441					
	1/25	1/25	60	72	6.96	490					
	1/30	1/29	50	60	8.33	539					
	1/40	1/40	37.5	45	10.8	784					
	1/50	1/50	30	36	13.7	882					
	1/60	1/58	25	30	16.7	882					
	1/80	1/80	18.8	22.5	20.6	1270					
	1/100	1/100	15	18	26.5	1270					
	1/120	1/120	12.5	15	31.4	1370					
	1/160	1/160	9.4	11.2	42.1	1370					
	1/200	1/200	7.5	9	52.9	1370					
	* 1/240	1/240	6.3	7.5	53.9	1370					
	1/300	91/27000	5	6	70.6	1760					
	1/375	11/4050	4	4.8	88.2	1760					
	1/450	637/297000	3.3	4	108	1760					
	1/600	221/129150	2.5	3	137	2740					
	1/750	187/135450	2	2.4	176	2740					
	1/900	169/147600	1.7	2	216	2740					
	1/1200	13/14964	1.3	1.5	284	5100					
	1/1500	11/15660	1	1.2	353	5100					
	1/1800	13/22446	0.8	1	421	5100					

Note 1: Please note that with regard to reduction ratios of 1/5 to 1/30 of 60 W gearmotors, the frame size for Three-phase standard voltages (200 V class) is 12, but the frame size for Three-phase high voltage (400 V class) and Single-phase voltages is 15.

G/G3 Type
Parallel Shaft

H/H2 Type
Right Angle Shaft

F Type
Right Angle Hollow Bore/
Right Angle Shaft

F2/F3 Type
Concentric Right Angle Hollow Bore/
Concentric Right Angle Shaft

Technical Documentation

Series	Motor Power	Frame Size	Reduction Ratio	Actual Reduction Ratio	Output Shaft Speed		Allowable Output Shaft Torque	Allowable Output Shaft O.H.L.	Drawings		
					r/min				Foot Mount	Flange Mount	Small Flange Mount
					50 Hz	60 Hz	N·m	N			
MINI	90 W	15	1/5	1/5	300	360	2.06	147	P.69	P.88	-
			1/7.5	1/7.5	200	240	3.14	245			
			1/10	1/10	150	180	4.12	343			
			1/15	1/15	100	120	6.17	441			
			1/20	1/20	75	90	8.33	539			
			1/25	1/25	60	72	10.8	588			
			1/30	1/29	50	60	12.7	686			
		18	1/40	1/40	37.5	45	16.7	1080	P.70	P.89	-
			1/50	1/50	30	36	20.6	1180			
			1/60	1/60	25	30	24.5	1180			
			1/80	1/80	18.8	22.5	31.4	1270			
			1/100	1/100	15	18	39.2	1270			
			1/120	1/120	12.5	15	47.0	1370			
			* 1/160	1/160	9.4	11.2	53.9	1370			
		* 1/200	1/200	7.5	9	53.9	1370				
		* 1/240	1/240	6.3	7.5	53.9	1370				
		28	1/300	221/64575	5	6	108	2740	P.76	P.95	P.110
			1/375	187/67725	4	4.8	137	2740			
			1/450	169/73800	3.3	4	157	2740			
		32	1/600	13/7740	2.5	3	216	5100	P.79	P.98	P.113
			1/750	11/8100	2	2.4	265	5100			
			1/900	13/11610	1.7	2	314	5100			
		40	1/1200	13/14964	1.3	1.5	421	7060	P.82	P.101	-
			1/1500	11/15660	1	1.2	529	7060			
			1/1800	13/22443	0.8	1	637	7060			

Note 1: Please be sure to read the notes on page 60.

G3 Type Gearmotors/Gearmotors with Brake

[Notes]

- The output shaft speed is the value relative to the synchronous speed of the motor and the reduction ratio.
-  in the performance table indicates that the shaft rotates clockwise when viewed from the output shaft side when the connection is made as shown on page 493 (CW). (Refer to the figure on the right)
- Allowable output shaft O.H.L. is the value at the middle of the output shaft.
- The “*” mark indicates a limited torque type. Please make sure to check the allowable output shaft torque in the performance table.

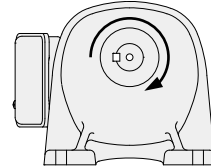

Series	Motor Power	Frame Size	Reduction Ratio	Actual Reduction Ratio	Output Shaft Speed		Allowable Output Shaft Torque		Allowable Output Shaft O.H.L.	Drawings			
					r/min		N·m			N	Foot Mount	Flange Mount	Small Flange Mount
					50 Hz	60 Hz	50 Hz	60 Hz					
MID	3-Phase 0.1 kW	18	1/5	33/164	300	360	3	2.5	770	P.71	P.90	P.105	
			1/10	77/779	150	180	6.1	5	1140				
			1/15	119/1804	100	120	9.1	7.5	1270				
			1/20	49/984	75	90	12	9.8	1530				
			1/25	28/697	60	72	15	12.7	1650				
			1/30	35/1066	50	60	19	14.7	1780				
		1/40	35/1404	37.5	45	24	19.6	1910					
		1/50	7/351	30	36	29	24.5	2040					
		22	1/60	11/684	25	30	35	29.4	2800	P.74	P.93	P.108	
			1/80	21/1634	18.8	22.5	47	39.2	3180				
			1/100	7/684	15	18	59	49	3180				
			1/120	147/17974	12.5	15	71	58.8	3180				
			1/160	21/3268	9.4	11.2	94	78.4	3180				
			1/200	21/4085	7.5	9	117	98	3180				
		28	1/300	221/65190	5	6	157	130	3430	P.77	P.96	P.111	
			1/375	187/68370	4	4.8	196	163	3430				
			1/450	1183/521520	3.3	4	235	196	3430				
		32	1/600	147/88192	2.5	3	313	261	5880	P.80	P.99	P.114	
			1/750	49/36464	2	2.4	391	326	5880				
			* 1/900	62/57063	1.7	2	431	391	5880				
			* 1/1200	46/55195	1.3	1.5	431	431	5880				
		3-Phase 0.2 kW	18	1/5	33/164	300	360	6.1	5	770	P.71	P.90	P.105
				1/10	77/779	150	180	11.8	9.8	1140			
				1/15	119/1804	100	120	18.6	14.7	1270			
	1/20			49/984	75	90	24.5	20.6	1450				
	1/25			28/697	60	72	30.4	25.5	1550				
	1/30			7/216	50	60	36.3	30.4	2280				
	22		1/40	91/3600	37.5	45	47	39.2	2410	P.74	P.93	P.108	
			1/50	11/540	30	36	58.8	49	2540				
			1/60	637/39600	25	30	70.6	58.8	2800				
			1/80	91/7200	18.8	22.5	94.1	78.4	3000				
			* 1/100	11/1080	15	18	97	80.4	3180				
			1/100	13/1353	15	18	117	98	3690				
	28		1/120	91/11000	12.5	15	140	117	4320	P.77	P.96	P.111	
			1/160	1/165	9.4	11.2	187	156	4450				
			1/200	7/1375	7.5	9	234	195	4450				
			1/300	91/27348	5	6	313	261	5880				
	32		1/375	77/28620	4	4.8	391	326	5880	P.80	P.99	P.114	
			1/450	91/41022	3.3	4	431	391	5880				
			1/600	9/5300	2.5	3	626	521	7060				
	40		* 1/750	62/46427	2	2.4	764	653	7060	P.83	P.102	-	
			* 1/900	23/21259	1.7	2	764	764	7060				
			* 1/1200	9/10600	1.3	1.5	764	764	7060				

G/G3 Type
Parallel Shaft

H/H2 Type
Right Angle Shaft

F Type
Right Angle Hollow Bore/
Right Angle Shaft

F2/F3 Type
Concentric Right Angle Hollow Bore/
Concentric Right Angle Shaft

Technical Documentation

Series	Motor Power	Frame Size	Reduction Ratio	Actual Reduction Ratio	Output Shaft Speed		Allowable Output Shaft Torque		Allowable Output Shaft O.H.L.	Drawings		
					r/min		N·m			Foot Mount	Flange Mount	Small Flange Mount
					50 Hz	60 Hz	50 Hz	60 Hz	N			
MID	3-Phase 0.4 kW	22	1/5	7/34	300	360	12	10	1140	P.74	P.93	P.108
			1/10	7/68	150	180	25	21	1530			
			1/15	49/748	100	120	36	30	1780			
			1/20	7/136	75	90	48	40	1910			
			1/25	7/170	60	72	61	50	2050			
		28	1/30	1/30	50	60	73	61	3310	P.77	P.96	P.111
			1/40	221/8610	37.5	45	94	78	3690			
			1/50	187/9030	30	36	117	98	4080			
			1/60	169/9840	25	30	140	117	4450			
			1/80	65/5166	18.8	22.5	187	156	4450			
		32	* 1/100	55/5418	15	18	193	161	4450	P.80	P.99	P.114
			1/100	7/688	15	18	234	195	6370			
			1/120	77/9360	12.5	15	281	234	7640			
			1/160	21/3328	9.4	11.2	374	313	7640			
		40	1/200	189/38272	7.5	9	431	390	7640	P.83	P.102	-
			1/300	7/2160	5	6	626	521	7060			
			* 1/375	77/29328	4	4.8	764	653	7060			
		50	* 1/450	49/21600	3.3	4	764	764	7060	P.85	P.104	-
			* 1/600	57/35360	2.5	3	1225	1044	9800			
			* 1/750	25/19448	2	2.4	1225	1225	9800			
* 1/900	5/4338		1.7	2	1225	1225	9800					
			* 1/1200	33/40664	1.3	1.5	1225	1225	9800			

Note 1: Please be sure to read the notes on page 63.

1-2. Performance Table

Series	Motor Power	Frame Size	Reduction Ratio	Actual Reduction Ratio	Output Shaft Speed		Allowable Output Shaft Torque		Allowable Output Shaft O.H.L.	Drawings					
					r/min		N·m			Foot Mount	Flange Mount	Small Flange Mount			
					50 Hz	60 Hz	50 Hz	60 Hz	N						
MID	3-Phase 0.75 kW	28	1/5	91/459	300	360	23	19	1650	P.77	P.96	P.111			
			1/10	1/10	150	180	45	38	2280						
			1/15	91/1360	100	120	68	57	2800						
			1/20	5/102	75	90	91	75	3050						
			1/25	7/170	60	72	114	94	3180						
		32	1/30	3/92	50	60	136	114	5220	P.80	P.99	P.114			
			1/40	13/516	37.5	45	175	146	5470						
			1/50	11/540	30	36	220	183	5780						
			1/60	13/774	25	30	264	220	6080						
			1/80	13/1032	18.8	22.5	351	293	6180						
		40	* 1/100	11/1080	15	18	362	302	6770	P.83	P.102	-			
			1/100	91/9000	15	18	439	366	9170						
			1/120	77/9400	12.5	15	527	439	9170						
			1/160	9/1400	9.4	11.2	703	585	9170						
		50	1/200	9/1750	7.5	9	764	732	9170	P.85	P.104	-			
			1/300	211/62013	5	6	1176	978	9800						
			* 1/375	94/36103	4	4.8	1225	1225	9800						
		3-Phase 1.5 kW	32	32	1/5	1/5	300	360	45	38	2280	P.80	P.99	P.114	
					1/10	1/10	150	180	91	75	3180				
					1/15	1/15	100	120	136	114	3690				
					1/20	1/20	75	90	181	151	4190				
					1/25	9/230	60	72	226	189	4410				
				40	1/30	1/30	50	60	272	226	6600	P.83	P.102	-	
					1/40	13/540	37.5	45	351	293	6960				
	1/50				11/564	30	36	439	366	6960					
	1/60				91/5400	25	30	527	439	7210					
	1/80				13/1080	18.8	22.5	703	585	7400					
	* 1/100				11/1128	15	18	724	603	7400					
	1/100				25/2618	15	18	878	732	12500					
	50		1/120	77/8993	12.5	15	1060	878	12500	P.85	P.104	-			
			* 1/160	33/5474	9.4	11.2	1230	1170	12500						
			* 1/200	30/5831	7.5	9	1230	1230	12500						
			1/5	7/36	300	360	67	56	2800				P.83	P.102	-
			1/10	7/72	150	180	133	111	4080						
	1/15		49/720	100	120	200	167	4580							
	1/20		7/144	75	90	266	221	5220							
	1/25		7/180	60	72	332	277	6110							
	3-Phase 2.2 kW		40	1/30	5/154	50	60	399	332	9040	P.85	P.104	-		
				1/40	399/15488	37.5	45	515	429	9420					
				1/50	399/20240	30	36	644	537	10000					
				1/60	49/2904	25	30	773	644	10000					
		50	1/80	49/3795	18.8	22.5	1029	858	10100	P.85	P.104	-			
			* 1/100	21/2116	15	18	1230	1080	10100						

Note 1: Please be sure to read the notes on page 63.

G/G3 Type
Parallel Shaft

H/H2 Type
Right Angle Shaft

F Type
Right Angle Hollow Bore/
Right Angle Shaft

F2/F3 Type
Concentric Right Angle Hollow Bore/
Concentric Right Angle Shaft

Technical Documentation

G3 Type Gearmotors/Gearmotors with Brake

[Notes]

- The output shaft speed is the value relative to the synchronous speed of the motor and the reduction ratio.
- in the performance table indicates that the shaft rotates clockwise when viewed from the output shaft side when the connection is made as shown on page 484 (CW). (Refer to the figure on the right)
- Allowable output shaft O.H.L. is the value at the middle of the output shaft.
- The “*” mark indicates a limited torque type. Please make sure to check the allowable output shaft torque in the performance table.

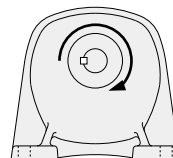

Series	Motor Power	Frame Size	Reduction Ratio	Actual Reduction Ratio	Output Shaft Speed		Allowable Output Shaft Torque		Allowable Output Shaft O.H.L.	Drawings		
					r/min		N·m		N	Foot Mount	Flange Mount	Small Flange Mount
					50 Hz	60 Hz	50 Hz	60 Hz				
MID	1-Phase 0.1 kW	18	1/5	33/164	300	360	3	2.5	770	P.72	P.91	P.106
			1/10	77/779	150	180	6.1	5	1140			
			1/15	119/1804	100	120	9.1	7.5	1270			
			1/20	49/984	75	90	12	9.8	1530			
			1/25	28/697	60	72	15	12.7	1650			
			1/30	35/1066	50	60	19	14.7	1780			
		1/40	35/1404	37.5	45	24	19.6	1910				
		1/50	7/351	30	36	29	24.5	2040				
		22	1/60	11/684	25	30	35	29.4	2800	P.75	P.94	P.109
			1/80	21/1634	18.8	22.5	47	39.2	3180			
			1/100	7/684	15	18	59	49	3180			
			1/120	147/17974	12.5	15	71	58.8	3180			
			1/160	21/3268	9.4	11.2	94	78.4	3180			
			1/200	21/4085	7.5	9	117	98	3180			
		28	1/300	221/65190	5	6	157	130	3430	P.78	P.97	P.112
			1/375	187/68370	4	4.8	196	163	3430			
			1/450	1183/521520	3.3	4	235	196	3430			
			1/600	147/88192	2.5	3	313	261	5880			
	32	1/750	49/36464	2	2.4	391	326	5880	P.81	P.100	P.115	
		* 1/900	62/57063	1.7	2	431	391	5880				
		* 1/1200	46/55195	1.3	1.5	431	431	5880				
	1-Phase 0.2 kW	18	1/5	33/164	300	360	6.1	5	770	P.72	P.91	P.106
			1/10	77/779	150	180	11.8	9.8	1140			
			1/15	119/1804	100	120	18.6	14.7	1270			
			1/20	49/984	75	90	24.5	20.6	1450			
			1/25	28/697	60	72	30.4	25.5	1550			
			1/30	7/216	50	60	36.3	30.4	2280			
		22	1/40	91/3600	37.5	45	47	39.2	2410	P.75	P.94	P.109
			1/50	11/540	30	36	58.8	49	2540			
			1/60	637/39600	25	30	70.6	58.8	2800			
			1/80	91/7200	18.8	22.5	94.1	78.4	3000			
			* 1/100	11/1080	15	18	97	80.4	3180			
			1/100	13/1353	15	18	117	98	3690			
		28	1/120	91/11000	12.5	15	140	117	4320	P.78	P.97	P.112
			1/160	1/165	9.4	11.2	187	156	4450			
			1/200	7/1375	7.5	9	234	195	4450			
1/300			91/27348	5	6	313	261	5880				
32		1/375	77/28620	4	4.8	391	326	5880	P.81	P.100	P.115	
		1/450	91/41022	3.3	4	431	391	5880				
	1/600	9/5300	2.5	3	626	521	7060					
	* 1/750	62/46427	2	2.4	764	653	7060					
40	* 1/900	23/21259	1.7	2	764	764	7060	P.84	P.103	-		
	* 1/1200	9/10600	1.3	1.5	764	764	7060					

1-2. Performance Table

Series	Motor Power	Frame Size	Reduction Ratio	Actual Reduction Ratio	Output Shaft Speed		Allowable Output Shaft Torque		Allowable Output Shaft O.H.L.	Drawings				
					r/min		N·m		N	Foot Mount	Flange Mount	Small Flange Mount		
					50 Hz	60 Hz	50 Hz	60 Hz						
MID	1-Phase 0.4 kW	22	1/5	7/34	300	360	12	10	1140	P.75	P.94	P.109		
			1/10	7/68	150	180	25	21	1530					
			1/15	49/748	100	120	36	30	1780					
			1/20	7/136	75	90	48	40	1910					
			1/25	7/170	60	72	61	50	2050					
		28	1/30	1/30	50	60	73	61	3310	P.78	P.97	P.112		
			1/40	221/8610	37.5	45	94	78	3690					
			1/50	187/9030	30	36	117	98	4080					
			1/60	169/9840	25	30	140	117	4450					
			1/80	65/5166	18.8	22.5	187	156	4450					
		32	* 1/100	55/5418	15	18	193	161	4450	P.81	P.100	P.115		
			1/100	7/688	15	18	234	195	6370					
			1/120	77/9360	12.5	15	281	234	7640					
			1/160	21/3328	9.4	11.2	374	313	7640					
		40	1/200	189/38272	7.5	9	431	390	7640	P.84	P.103	-		
			1/300	7/2160	5	6	626	521	7060					
			* 1/375	77/29328	4	4.8	764	653	7060					
		50	* 1/450	49/21600	3.3	4	764	764	7060	P.86	P.105	-		
			* 1/600	57/35360	2.5	3	1225	1044	9800					
			* 1/750	25/19448	2	2.4	1225	1225	9800					
			* 1/900	5/4338	1.7	2	1225	1225	9800					
					* 1/1200	33/40664	1.3	1.5	1225	1225	9800			

G/G3 Type
Parallel Shaft

H/H2 Type
Right Angle Shaft

F Type
Right Angle Hollow Bore/
Right Angle Shaft

F2/F3 Type
Concentric Right Angle Hollow Bore/
Concentric Right Angle Shaft

Technical Documentation

1-3. Drawings

G Type Parallel Shaft Shaft Diameter **12** **Foot Mounting**

The values in parenthesis are those for gearmotors with a brake.

<Figure 1>

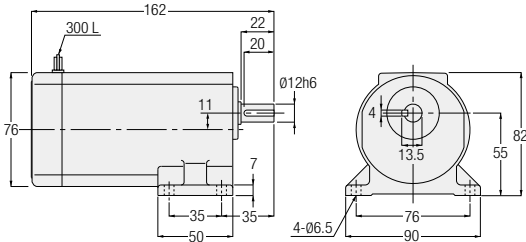

<Figure 2>

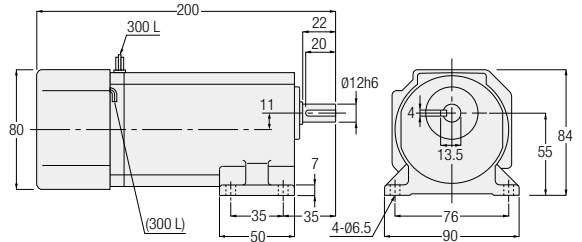

Number of Phases	Power	Part Number	Reduction Ratio	Figure Number	Brake	Approx. Weight (kg)
3-Phase	15 W	GLM-12-***-T15	5, 7.5, 10, 15, 20, 25, 30, 40, 50, 60, 80, 100, 120, 160, 200, 240	1	No	2
		GLMN-12-***-T15W		2	Yes	2
		GLM-12-***-T15	5, 7.5, 10, 15, 20, 25, 30, 40, 50, 60, 80, 100, 120, 160, 200, 240	1	No	2
		GLMN-12-***-T15W		2	Yes	2
	25 W	GLM-12-***-T25	5, 7.5, 10, 15, 20, 25, 30, 40, 50, 60, 80, 100, 120	1	No	2
		GLMN-12-***-T25W		2	Yes	2
		GLM-12-***-T25	5, 7.5, 10, 15, 20, 25, 30, 40, 50, 60, 80, 100, 120	1	No	2
		GLMN-12-***-T25W		2	Yes	2
	40 W	GLM-12-***-T40	5, 7.5, 10, 15, 20, 25, 30, 40, 50, 60	1	No	2
		GLMN-12-***-T40W		2	Yes	2
		GLM-12-***-T40	5, 7.5, 10, 15, 20, 25, 30, 40, 50, 60	1	No	2
		GLMN-12-***-T40W		2	Yes	2
60 W	GLM-12-***-T60	5, 7.5, 10, 15, 20, 25, 30	2	No	2	
	GLMN-12-***-T60		2	Yes	2	
1-Phase	15 W	GLM-12-***-S15	5, 7.5, 10, 15, 20, 25, 30, 40, 50, 60, 80, 100, 120, 160, 200, 240	1	No	2
		GLMN-12-***-S15W		2	Yes	2
		GLM-12-***-S15	5, 7.5, 10, 15, 20, 25, 30, 40, 50, 60, 80, 100, 120, 160, 200, 240	1	No	2
		GLMN-12-***-S15W		2	Yes	2
	25 W	GLM-12-***-S25	5, 7.5, 10, 15, 20, 25, 30, 40, 50, 60, 80, 100, 120	1	No	2
		GLMN-12-***-S25W		2	Yes	2
		GLM-12-***-S25	5, 7.5, 10, 15, 20, 25, 30, 40, 50, 60, 80, 100, 120	1	No	2
		GLMN-12-***-S25W		2	Yes	2
	40 W	GLM-12-***-S40	5, 7.5, 10, 15, 20, 25, 30, 40, 50, 60	2	No	2
		GLMN-12-***-S40W		2	Yes	2
		GLM-12-***-S40	5, 7.5, 10, 15, 20, 25, 30, 40, 50, 60	2	No	2
		GLMN-12-***-S40W		2	Yes	2

Note: A reduction ratio will be indicated as *** in the nomenclature.
 Note: Please refer to page 60 for the performance table.

G/G3 Type Parallel Shaft

H/H2 Type Right Angle Shaft

F Type Right Angle Hollow Bore/ Right Angle Shaft

F2/F3 Type Concentric Right Angle Hollow Bore/ Concentric Right Angle Shaft

Technical Documentation

G Type Parallel Shaft Shaft Diameter **15** **Foot Mounting**

The values in parenthesis are those for gearmotors with a brake.

<Figure 1>

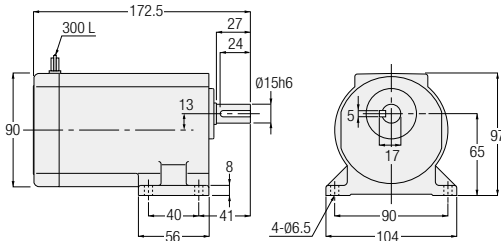

<Figure 2>

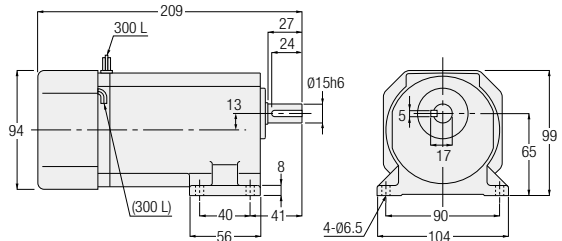

Number of Phases	Power	Part Number	Reduction Ratio	Figure Number	Brake	Approx. Weight (kg)
3-Phase	25 W	GLM-15-***-T25	160, 200, 240	1	No	3
		GLM-15-***-T25W				
		GLMN-15-***-T25	160, 200, 240	2	Yes	3
		GLMN-15-***-T25W				
	40 W	GLM-15-***-T40	80, 100, 120	1	No	3
		GLM-15-***-T40W				
		GLMN-15-***-T40	80, 100, 120	2	Yes	3
	60 W	GLM-15-***-T60	40, 50, 60	1	No	3
		GLM-15-***-T60W	5, 7.5, 10, 15, 20, 25, 30, 40, 50, 60			
		GLMN-15-***-T60	40, 50, 60	2	Yes	3
		GLMN-15-***-T60W	5, 7.5, 10, 15, 20, 25, 30, 40, 50, 60			
	90 W	GLM-15-***-T90	5, 7.5, 10, 15, 20, 25, 30	1	No	3
GLM-15-***-T90W						
GLMN-15-***-T90		5, 7.5, 10, 15, 20, 25, 30	2	Yes	3	
GLMN-15-***-T90W						
1-Phase	25 W	GLM-15-***-S25	160, 200, 240	1	No	3
		GLM-15-***-S25W				
		GLMN-15-***-S25	160, 200, 240	2	Yes	3
		GLMN-15-***-S25W				
	40 W	GLM-15-***-S40	80, 100, 120	1	No	3
		GLM-15-***-S40W				
		GLMN-15-***-S40	80, 100, 120	2	Yes	3
	60 W	GLM-15-***-S60	5, 7.5, 10, 15, 20, 25, 30, 40, 50, 60	2	No	3
		GLM-15-***-S60W				
		GLMN-15-***-S60	5, 7.5, 10, 15, 20, 25, 30, 40, 50, 60	2	Yes	3
		GLMN-15-***-S60W				
	90 W	GLM-15-***-S90	5, 7.5, 10, 15, 20, 25, 30	2	No	3
GLM-15-***-S90W						
GLMN-15-***-S90		5, 7.5, 10, 15, 20, 25, 30	2	Yes	3	
GLMN-15-***-S90W						

Note: A reduction ratio will be indicated as *** in the nomenclature.
 Note: Please refer to page 60 for the performance table.

G/G3 Type Parallel Shaft

H/H2 Type Right Angle Shaft

F Type Right Angle Hollow Bore/ Right Angle Shaft

F2/F3 Type Concentric Right Angle Hollow Bore/ Concentric Right Angle Shaft

Technical Documentation

G Type Parallel Shaft Shaft Diameter **18** **Foot Mounting**

The values in parenthesis are those for gearmotors with a brake.

<Figure 1>

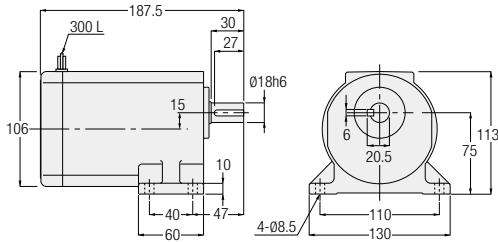

<Figure 2>

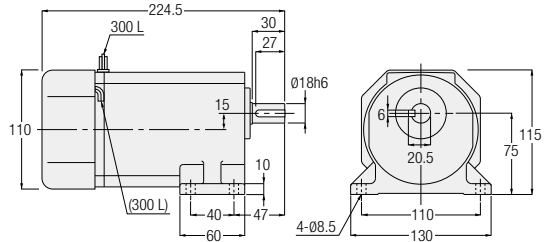

Number of Phases	Power	Part Number	Reduction Ratio	Figure Number	Brake	Approx. Weight (kg)
3-Phase	40 W	GLM-18-***-T40	160, 200, 240	1	No	4
		GLM-18-***-T40W				
		GLMN-18-***-T40	160, 200, 240	2	Yes	4
		GLMN-18-***-T40W				
	60 W	GLM-18-***-T60	80, 100, 120, 160, 200, 240	1	No	4
		GLM-18-***-T60W				
		GLMN-18-***-T60	80, 100, 120, 160, 200, 240	2	Yes	4
		GLMN-18-***-T60W				
	90 W	GLM-18-***-T90	40, 50, 60, 80, 100, 120, 160, 200, 240	1	No	4
		GLM-18-***-T90W				
		GLMN-18-***-T90	40, 50, 60, 80, 100, 120, 160, 200, 240	2	Yes	4
		GLMN-18-***-T90W				
1-Phase	40 W	GLM-18-***-S40	160, 200, 240	1	No	4
		GLM-18-***-S40W				
		GLMN-18-***-S40	160, 200, 240	2	Yes	4
		GLMN-18-***-S40W				
	60 W	GLM-18-***-S60	80, 100, 120, 160, 200, 240	1	No	4
		GLM-18-***-S60W				
		GLMN-18-***-S60	80, 100, 120, 160, 200, 240	2	Yes	4
		GLMN-18-***-S60W				
	90 W	GLM-18-***-S90	40, 50, 60, 80, 100, 120, 160, 200, 240	2	No	4
		GLM-18-***-S90W				
		GLMN-18-***-S90	40, 50, 60, 80, 100, 120, 160, 200, 240	2	Yes	4
		GLMN-18-***-S90W				

Note: A reduction ratio will be indicated as *** in the nomenclature.
 Note: Please refer to page 61 for the performance table.

G3 Type Parallel Shaft Shaft Diameter **18** Foot Mounting

The values in parenthesis are those for gearmotors with a brake.

<Figure 1>

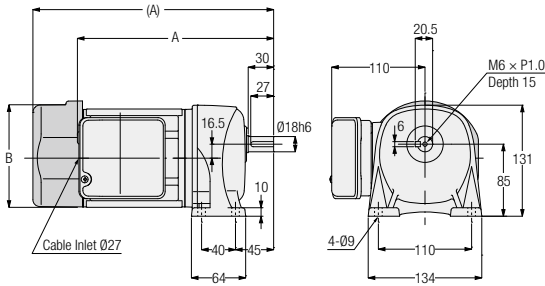

Number of Phases	Power	Part Number	Reduction Ratio	Figure Number	Brake	Approx. Weight (kg)	A	B
3-Phase	0.1 kW	G3L18N***-MM01T◇◇TN	5, 10, 15, 20, 25, 30, 40, 50	1	No	6	218.5	Ø115
		G3L18N***-MM01T◇◇TB◆			Yes	7.5	258.5	□126
	0.2 kW	G3L18N***-MM02T◇◇TN	5, 10, 15, 20, 25	1	No	6.5	233.5	Ø115
		G3L18N***-MM02T◇◇TB◆			Yes	8	284	□126

Note: A reduction ratio will be indicated as *** in the nomenclature. In addition, a supply voltage/certification code will be indicated as ◇◇, and a brake specification will be indicated as ◆.

Note: Please refer to page 63 for the performance table.

G/G3 Type Parallel Shaft

H/H2 Type Right Angle Shaft

F Type Right Angle Hollow Bore/Right Angle Shaft

F2/F3 Type Concentric Right Angle Hollow Bore/Concentric Right Angle Shaft

Technical Documentation

G3 Type Parallel Shaft Shaft Diameter **18** **Foot Mounting**

The values in parenthesis are those for gearmotors with a brake.

<Figure 1>

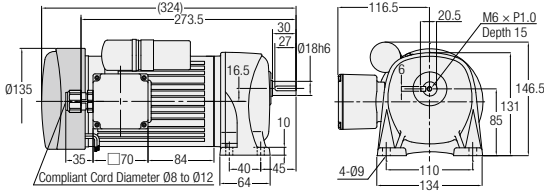

<Figure 2>

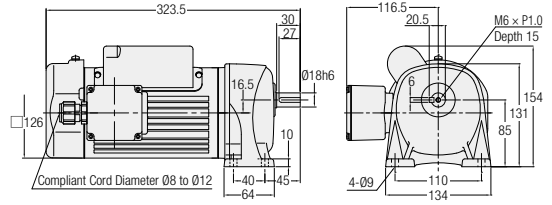

<Figure 3>

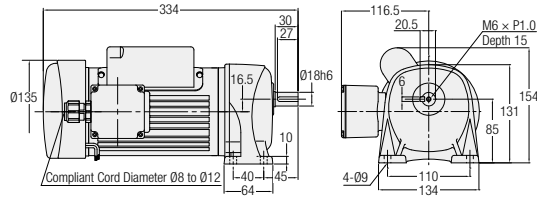

Number of Phases	Power	Part Number	Reduction Ratio	Figure Number	Brake	Approx. Weight (kg)
1-Phase	0.1 kW	G3L18N***-MM01C◇JAN	5, 10, 15, 20, 25, 30, 40, 50	1	No	7.5
		G3L18N***-MM01C◇JAB2			Yes	9
	0.2 kW	G3L18N***-MM02C◇JAN	5, 10, 15, 20, 25	2	No	8.5
		G3L18N***-MM02C◇JAB2			Yes	10

Note: A reduction ratio will be indicated as *** in the nomenclature. In addition, a supply voltage code will be indicated as ◇.
 Note: Please refer to page 66 for the performance table.

G Type Parallel Shaft Shaft Diameter **22** Foot Mounting

The values in parenthesis are those for gearmotors with a brake.

<Figure 1>

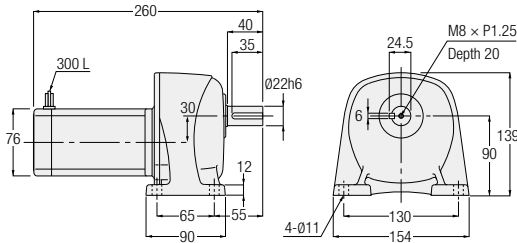

<Figure 2>

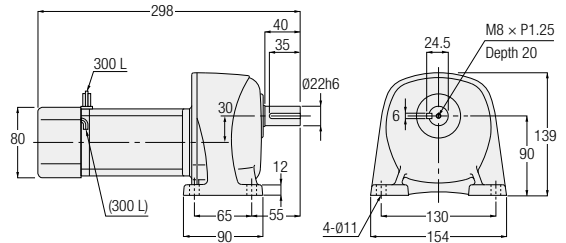

Number of Phases	Power	Part Number	Reduction Ratio	Figure Number	Brake	Approx. Weight (kg)
3-Phase	15 W	GLM-22-***-T15	300, 375, 450, 600, 750, 900, 1200, 1500, 1800	1	No	5
		GLM-22-***-T15W				
		GLMN-22-***-T15	300, 375, 450, 600, 750, 900, 1200, 1500, 1800	2	Yes	5
		GLMN-22-***-T15W				
	25 W	GLM-22-***-T25	300, 375, 450, 600, 750, 900	1	No	5
		GLM-22-***-T25W				
		GLMN-22-***-T25	300, 375, 450, 600, 750, 900	2	Yes	5
		GLMN-22-***-T25W				
	40 W	GLM-22-***-T40	300, 375, 450	1	No	5
		GLM-22-***-T40W				
		GLMN-22-***-T40	300, 375, 450	2	Yes	5
		GLMN-22-***-T40W				
60 W	GLM-22-***-T60	300, 375, 450	2	No	5	
	GLM-22-***-T60W					
	GLMN-22-***-T60	300, 375, 450	2	Yes	5	
	GLMN-22-***-T60W					
1-Phase	15 W	GLM-22-***-S15	300, 375, 450, 600, 750, 900, 1200, 1500, 1800	1	No	5
		GLM-22-***-S15W				
		GLMN-22-***-S15	300, 375, 450, 600, 750, 900, 1200, 1500, 1800	2	Yes	5
		GLMN-22-***-S15W				
	25 W	GLM-22-***-S25	300, 375, 450, 600, 750, 900	1	No	5
		GLM-22-***-S25W				
		GLMN-22-***-S25	300, 375, 450, 600, 750, 900	2	Yes	5
		GLMN-22-***-S25W				
	40 W	GLM-22-***-S40	300, 375, 450	2	No	5
		GLM-22-***-S40W				
		GLMN-22-***-S40	300, 375, 450	2	Yes	5
		GLMN-22-***-S40W				
	60 W	GLM-22-***-S60	300, 375, 450	2	No	5
		GLM-22-***-S60W				
		GLMN-22-***-S60	300, 375, 450	2	Yes	5
		GLMN-22-***-S60W				

Note: A reduction ratio will be indicated as *** in the nomenclature.
 Note: Please refer to page 60 for the performance table.

G/G3 Type Parallel Shaft

H/H2 Type Right Angle Shaft

F Type Right Angle Hollow Bore/ Right Angle Shaft

F2/F3 Type Concentric Right Angle Hollow Bore/ Concentric Right Angle Shaft

Technical Documentation

G3 Type Parallel Shaft

Shaft Diameter **22**

Foot Mounting

The values in parenthesis are those for gearmotors with a brake.

<Figure 1>

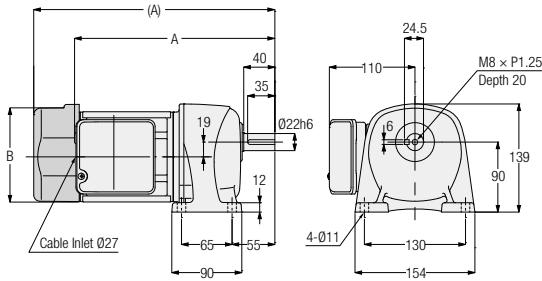

<Figure 2>

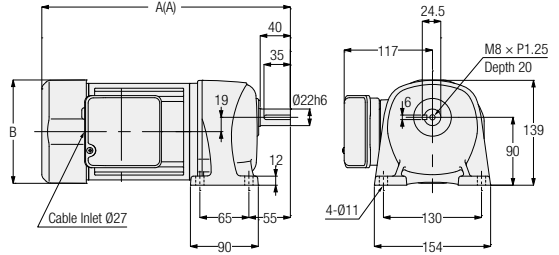

Number of Phases	Power	Part Number	Reduction Ratio	Figure Number	Brake	Approx. Weight (kg)	A	B
3-Phase	0.1 kW	G3L22N***-MM01T◇◇TN	60, 80, 100, 120, 160, 200	1	No	7	244.5	Ø115
		G3L22N***-MM01T◇◇TB◆			Yes	8.5	284.5	□126
	0.2 kW	G3L22N***-MM02T◇◇TN	30, 40, 50, 60, 80, 100	1	No	7.5	259.5	Ø115
		G3L22N***-MM02T◇◇TB◆			Yes	9	310	□126
	0.4 kW	G3L22N***-MM04T◇◇TN	5, 10, 15, 20, 25	2	No	9.5	309.5	□137
		G3L22N***-MM04T◇◇TB◆			Yes	11	329.5	□137

Note: A reduction ratio will be indicated as *** in the nomenclature. In addition, a supply voltage/certification code will be indicated as ◇◇, and a brake specification will be indicated as ◆.

Note: Please refer to page 63 for the performance table.

G/G3 Type Parallel Shaft

H/H2 Type Right Angle Shaft

F Type Right Angle Hollow Bore/ Right Angle Shaft

F2/F3 Type Concentric Right Angle Hollow Bore/ Concentric Right Angle Shaft

Technical Documentation

G3 Type Parallel Shaft Shaft Diameter **22** Foot Mounting

The values in parenthesis are those for gearmotors with a brake.

<Figure 1>

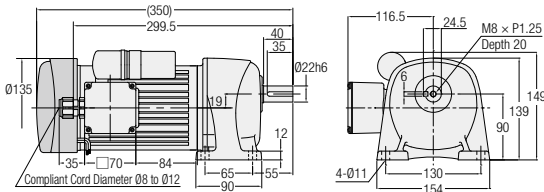

<Figure 2>

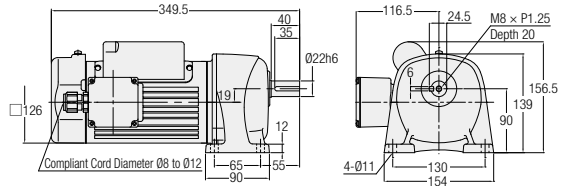

<Figure 3>

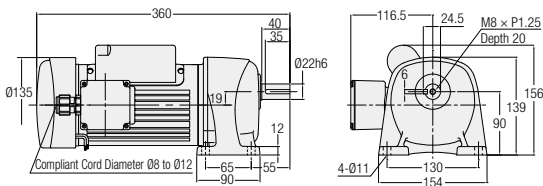

<Figure 4>

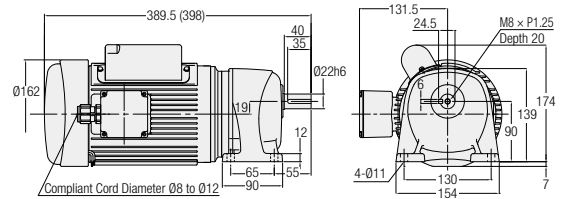

Number of Phases	Power	Part Number	Reduction Ratio	Figure Number	Brake	Approx. Weight (kg)
1-Phase	0.1 kW	G3L22N***-MM01C◇JAN	60, 80, 100, 120, 160, 200	1	No	8.5
		G3L22N***-MM01C◇JAB2			Yes	10
	0.2 kW	G3L22N***-MM02C◇JAN	30, 40, 50, 60, 80, 100	2	No	9.5
		G3L22N***-MM02C◇JAB2			Yes	11
	0.4 kW	G3L22N***-MM04C◇JAN	5, 10, 15, 20, 25	4	No	15
		G3L22N***-MM04C◇JAB2			Yes	17.5

Note: A reduction ratio will be indicated as *** in the nomenclature. In addition, a supply voltage code will be indicated as ◇.
 Note: Please refer to page 66 for the performance table.

G/G3 Type Parallel Shaft

H/H2 Type Right Angle Shaft

F Type Right Angle Hollow Bore/ Right Angle Shaft

F2/F3 Type Concentric Right Angle Hollow Bore/ Concentric Right Angle Shaft

Technical Documentation

G Type Parallel Shaft Shaft Diameter **28** **Foot Mounting**

The values in parenthesis are those for gearmotors with a brake.

<Figure 1>

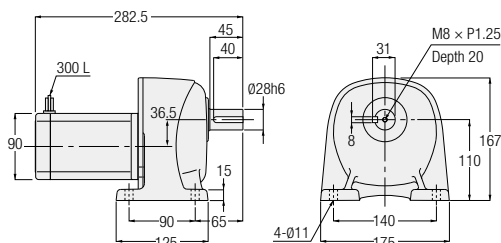

<Figure 2>

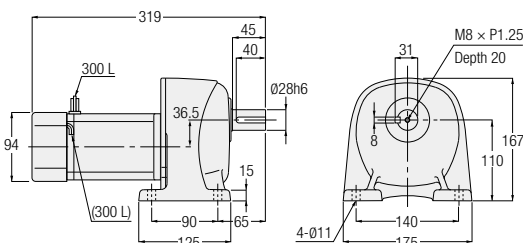

Number of Phases	Power	Part Number	Reduction Ratio	Figure Number	Brake	Approx. Weight (kg)	
3-Phase	25 W	GLM-28-***-T25	1200, 1500, 1800	1	No	7	
		GLM-28-***-T25W					
		GLMN-28-***-T25	1200, 1500, 1800	2	Yes	7	
		GLMN-28-***-T25W					
3-Phase	40 W	GLM-28-***-T40	600, 750, 900	1	No	7	
		GLM-28-***-T40W					
		GLMN-28-***-T40	600, 750, 900	2	Yes	7	
		GLMN-28-***-T40W					
3-Phase	60 W	GLM-28-***-T60	600, 750, 900	1	No	7	
		GLM-28-***-T60W					
		GLMN-28-***-T60	600, 750, 900	2	Yes	7	
		GLMN-28-***-T60W					
3-Phase	90 W	GLM-28-***-T90	300, 375, 450	1	No	7	
		GLM-28-***-T90W					
		GLMN-28-***-T90	300, 375, 450	2	Yes	7	
		GLMN-28-***-T90W					
1-Phase	25 W	GLM-28-***-S25	1200, 1500, 1800	1	No	7	
		GLM-28-***-S25W					
		GLMN-28-***-S25	1200, 1500, 1800	2	Yes	7	
		GLMN-28-***-S25W					
	1-Phase	40 W	GLM-28-***-S40	600, 750, 900	1	No	7
			GLM-28-***-S40W				
			GLMN-28-***-S40	600, 750, 900	2	Yes	7
			GLMN-28-***-S40W				
	1-Phase	60 W	GLM-28-***-S60	600, 750, 900	1	No	7
			GLM-28-***-S60W				
			GLMN-28-***-S60	600, 750, 900	2	Yes	7
			GLMN-28-***-S60W				
1-Phase	90 W	GLM-28-***-S90	300, 375, 450	1	No	7	
		GLM-28-***-S90W					
		GLMN-28-***-S90	300, 375, 450	2	Yes	7	
		GLMN-28-***-S90W					

Note: A reduction ratio will be indicated as *** in the nomenclature.
 Note: Please refer to page 60 for the performance table.

G3 Type Parallel Shaft Shaft Diameter **28** Foot Mounting

The values in parenthesis are those for gearmotors with a brake.

<Figure 1>

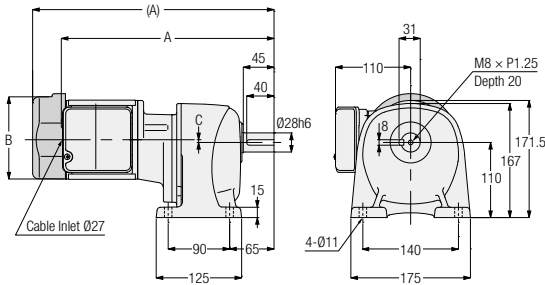

<Figure 2>

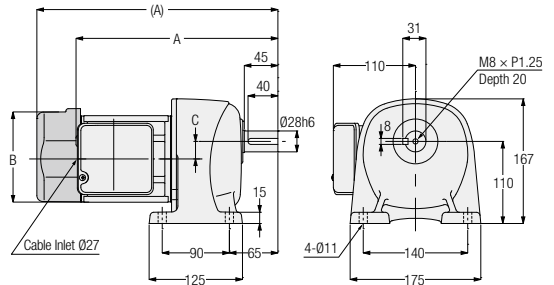

<Figure 3>

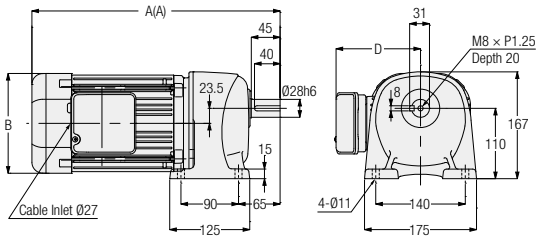

Number of Phases	Power	Part Number	Reduction Ratio	Figure Number	Brake	Approx. Weight (kg)	A	B	C	D
3-Phase	0.1 kW	G3L28N***-MM01T◇◇TN	300, 375, 450	1	No	10	313.5	Ø115	4	-
		Yes			11.5	353.5	□126	4	-	
	0.2 kW	G3L28N***-MM02T◇◇TN	100, 120, 160, 200	2	No	9.5	272.5	Ø115	23.5	-
		Yes			11	323	□126	23.5	-	
	0.4 kW	G3L28N***-MM04T◇◇TN	30, 40, 50, 60, 80, 100	3	No	11.5	325.5	□137	-	117
		Yes			13	345.5	□137	-	117	
0.75 kW	G3L28N***-MD08T◇◇TN	5, 10, 15, 20, 25	3	No	18.5	368	□156	-	132	
	Yes			21	388	□156	-	132		

Note: A reduction ratio will be indicated as *** in the nomenclature. In addition, a supply voltage/certification code will be indicated as ◇◇, and a brake specification will be indicated as ◆.

Note: Please refer to page 63 for the performance table.

G/G3 Type Parallel Shaft

H/H2 Type Right Angle Shaft

F Type Right Angle Hollow Bore/Right Angle Shaft

F2/F3 Type Concentric Right Angle Hollow Bore/Concentric Right Angle Shaft

Technical Documentation

G3 Type Parallel Shaft Shaft Diameter **28** Foot Mounting

The values in parenthesis are those for gearmotors with a brake.

<Figure 1>

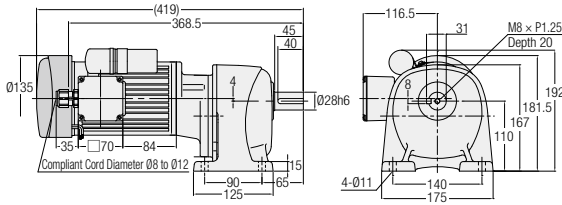

<Figure 2>

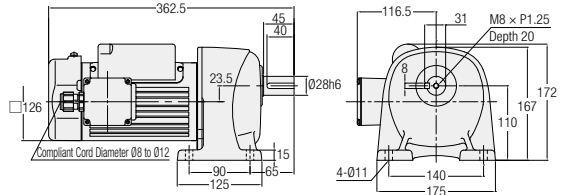

<Figure 3>

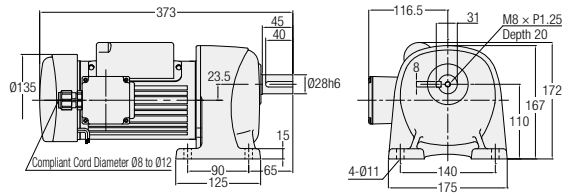

<Figure 4>

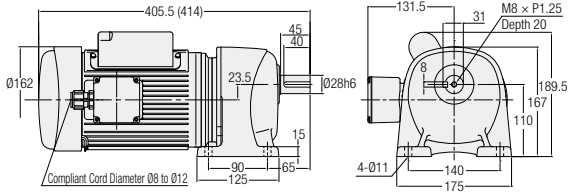

Number of Phases	Power	Part Number	Reduction Ratio	Figure Number	Brake	Approx. Weight (kg)
1-Phase	0.1 kW	G3L28N***-MM01C◇JAN	300, 375, 450	1	No	11.5
		G3L28N***-MM01C◇JAB2			Yes	13
	0.2 kW	G3L28N***-MM02C◇JAN	100, 120, 160, 200	2	No	11.5
		G3L28N***-MM02C◇JAB2			Yes	13
	0.4 kW	G3L28N***-MM04C◇JAN	30, 40, 50, 60, 80, 100	4	No	17
		G3L28N***-MM04C◇JAB2			Yes	19.5

Note: A reduction ratio will be indicated as *** in the nomenclature. In addition, a supply voltage code will be indicated as ◇.
 Note: Please refer to page 66 for the performance table.

G Type Parallel Shaft **Shaft Diameter 32** **Foot Mounting**

The values in parenthesis are those for gearmotors with a brake.

<Figure 1>

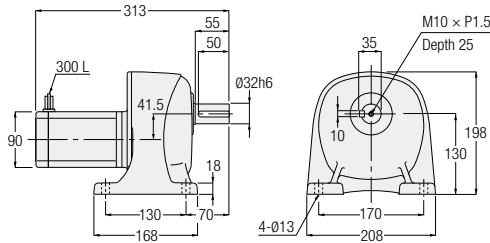

<Figure 2>

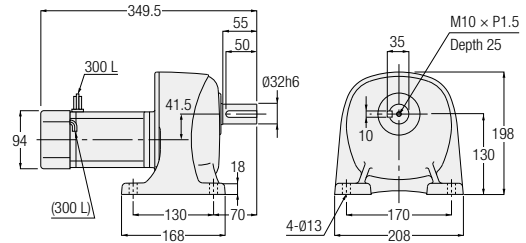

Number of Phases	Power	Part Number	Reduction Ratio	Figure Number	Brake	Approx. Weight (kg)
3-Phase	40 W	GLM-32-***-T40	1200, 1500, 1800	1	No	11
		GLM-32-***-T40W				
		GLMN-32-***-T40	1200, 1500, 1800	2	Yes	11
		GLMN-32-***-T40W				
	60 W	GLM-32-***-T60	1200, 1500, 1800	1	No	11
		GLM-32-***-T60W				
		GLMN-32-***-T60	1200, 1500, 1800	2	Yes	11
	GLMN-32-***-T60W					
	90 W	GLM-32-***-T90	600, 750, 900	1	No	11
GLM-32-***-T90W						
GLMN-32-***-T90		600, 750, 900	2	Yes	11	
GLMN-32-***-T90W						
1-Phase	40 W	GLM-32-***-S40	1200, 1500, 1800	1	No	11
		GLM-32-***-S40W				
		GLMN-32-***-S40	1200, 1500, 1800	2	Yes	11
		GLMN-32-***-S40W				
	60 W	GLM-32-***-S60	1200, 1500, 1800	2	No	11
		GLM-32-***-S60W				
		GLMN-32-***-S60	1200, 1500, 1800	2	Yes	11
	GLMN-32-***-S60W					
	90 W	GLM-32-***-S90	600, 750, 900	2	No	11
		GLM-32-***-S90W				
		GLMN-32-***-S90	600, 750, 900	2	Yes	11
		GLMN-32-***-S90W				

Note: A reduction ratio will be indicated as *** in the nomenclature.
 Note: Please refer to page 61 for the performance table.

G3 Type Parallel Shaft

Shaft Diameter **32**

Foot Mounting

The values in parenthesis are those for gearmotors with a brake.

<Figure 1>

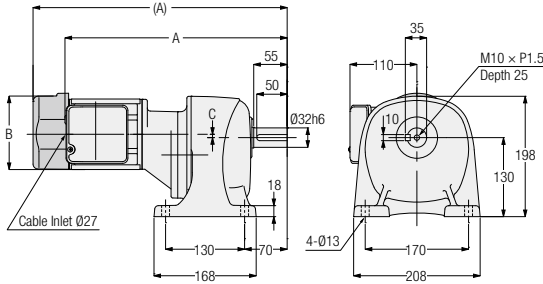

<Figure 2>

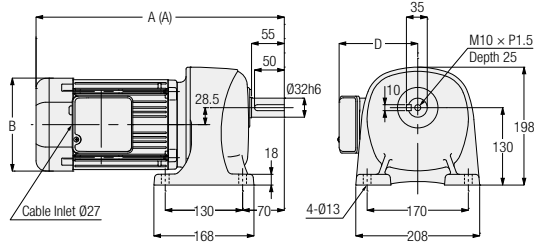

Number of Phases	Power	Part Number	Reduction Ratio	Figure Number	Brake	Approx. Weight (kg)	A	B	C	D
3-Phase	0.1 kW	G3L32N***-MM01T◇◇TN	600, 750, 900, 1200	1	No	13	332.5	Ø115	-1	-
		Yes			14.5	372.5	□126	-1	-	
	0.2 kW	G3L32N***-MM02T◇◇TN	300, 375, 450	1	No	13.5	367.5	Ø115	5.5	-
		Yes			15	418	□126	5.5	-	
	0.4 kW	G3L32N***-MM04T◇◇TN	100, 120, 160, 200	2	No	14.5	344.5	□137	-	117
		Yes			16	364.5	□137	-	117	
	0.75 kW	G3L32N***-MD08T◇◇TN	30, 40, 50, 60, 80, 100	2	No	22	397	□156	-	132
		Yes			24.5	417	□156	-	132	
	1.5 kW	G3L32N***-MD15T◇◇TN	5, 10, 15, 20, 25	2	No	28	449	□178	-	139
		Yes			31.5	478	□178	-	139	

Note: A reduction ratio will be indicated as *** in the nomenclature. In addition, a supply voltage/certification code will be indicated as ◇◇, and a brake specification will be indicated as ◆.

Note: Please refer to page 63 for the performance table.

G3 Type Parallel Shaft Shaft Diameter **32** Foot Mounting

The values in parenthesis are those for gearmotors with a brake.

<Figure 1>

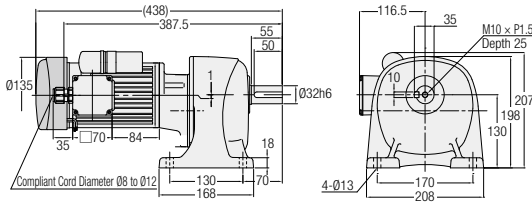

<Figure 2>

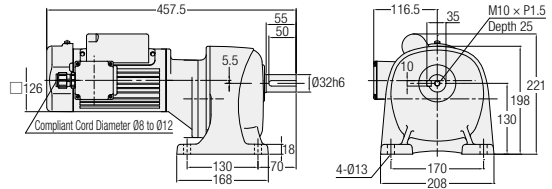

<Figure 3>

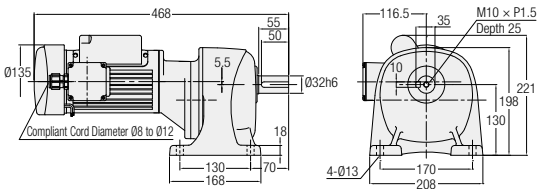

<Figure 4>

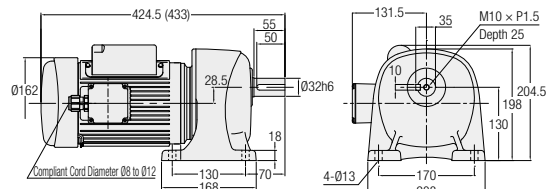

Number of Phases	Power	Part Number	Reduction Ratio	Figure Number	Brake	Approx. Weight (kg)
1-Phase	0.1 kW	G3L32N***-MM01C◇JAN	600, 750, 900, 1200	1	No	14.5
		G3L32N***-MM01C◇JAB2			Yes	16
	0.2 kW	G3L32N***-MM02C◇JAN	300, 375, 450	2	No	15.5
		G3L32N***-MM02C◇JAB2			Yes	17
	0.4 kW	G3L32N***-MM04C◇JAN	100, 120, 160, 200	4	No	20
		G3L32N***-MM04C◇JAB2			Yes	22.5

Note: A reduction ratio will be indicated as *** in the nomenclature. In addition, a supply voltage code will be indicated as ◇.
 Note: Please refer to page 66 for the performance table.

G/G3 Type Parallel Shaft

H/H2 Type Right Angle Shaft

F Type Right Angle Hollow Bore/ Right Angle Shaft

F2/F3 Type Concentric Right Angle Hollow Bore/ Concentric Right Angle Shaft

Technical Documentation

G Type Parallel Shaft Shaft Diameter **40** **Foot Mounting**

The values in parenthesis are those for gearmotors with a brake.

<Figure 1>

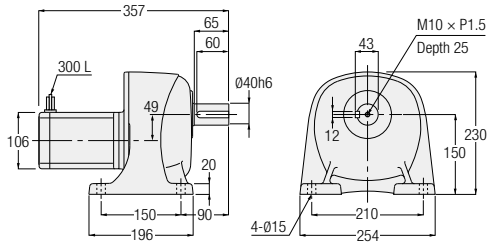

<Figure 2>

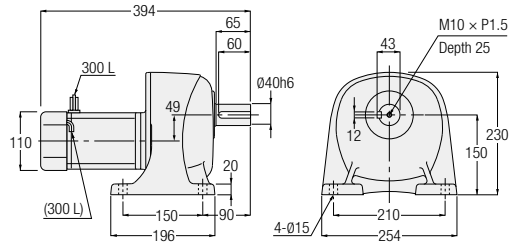

Number of Phases	Power	Part Number	Reduction Ratio	Figure Number	Brake	Approx. Weight (kg)
3-Phase	90 W	GLM-40-***-T90	1200, 1500, 1800	1	No	15
		GLM-40-***-T90W				
		GLMN-40-***-T90	1200, 1500, 1800	2	Yes	15
		GLMN-40-***-T90W				
1-Phase	90 W	GLM-40-***-S90	1200, 1500, 1800	2	No	15
		GLM-40-***-S90W				
		GLMN-40-***-S90	1200, 1500, 1800	2	Yes	15
		GLMN-40-***-S90W				

Note: A reduction ratio will be indicated as *** in the nomenclature.
 Note: Please refer to page 62 for the performance table.

G3 Type Parallel Shaft Shaft Diameter **40** **Foot Mounting**

The values in parenthesis are those for gearmotors with a brake.

<Figure 1>

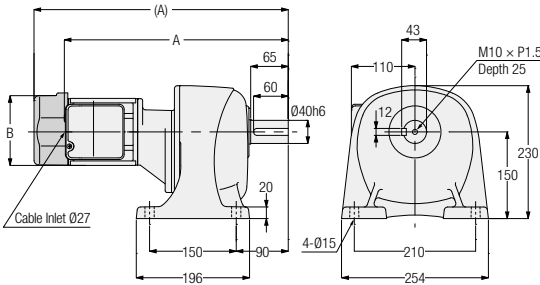

<Figure 2>

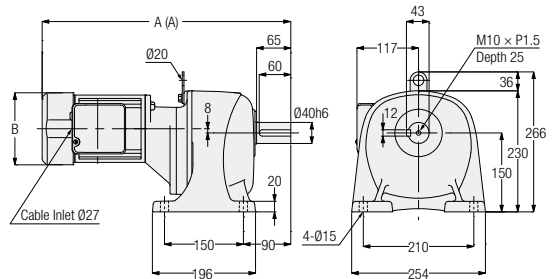

<Figure 3>

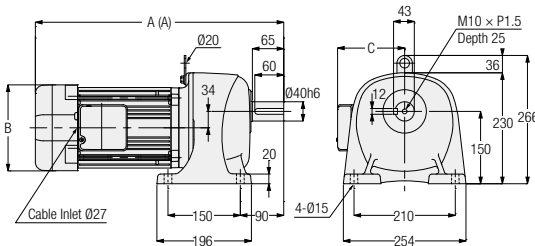

Note: Gearmotors with a motor power of 0.75 kW does not include the hanging plate.

Number of Phases	Power	Part Number	Reduction Ratio	Figure Number	Brake	Approx. Weight (kg)	A	B	C
3-Phase	0.2 kW	G3L40N***-MM02T◇◇TN	600, 750, 900, 1200	1	No	20	389.5	Ø115	-
		Yes			21.5	440	□126	-	
	0.4 kW	G3L40N***-MM04T◇◇TN	300, 375, 450	2	No	23	452.5	□137	-
		Yes			24.5	472.5	□137	-	
	0.75 kW	G3L40N***-MD08T◇◇TN	100, 120, 160, 200	3	No	28.5	419	□156	132
		Yes			31	439	□156	132	
	1.5 kW	G3L40N***-MD15T◇◇TN	30, 40, 50, 60, 80, 100	3	No	35	486	□178	139
		Yes			38.5	515	□178	139	
	2.2 kW	G3L40N***-MD22T◇◇TN	5, 10, 15, 20, 25	3	No	41.5	503.5	□192	149
		Yes			45.0	532.5	□192	149	

Note: A reduction ratio will be indicated as *** in the nomenclature. In addition, a supply voltage/certification code will be indicated as ◇◇, and a brake specification will be indicated as ◆.

Note: Please refer to page 63 for the performance table.

G/G3 Type Parallel Shaft

H/H2 Type Right Angle Shaft

F Type Right Angle Hollow Bore/Right Angle Shaft

F2/F3 Type Concentric Right Angle Hollow Bore/Concentric Right Angle Shaft

Technical Documentation

G3 Type Parallel Shaft Shaft Diameter **40** **Foot Mounting**

The values in parenthesis are those for gearmotors with a brake.

<Figure 1>

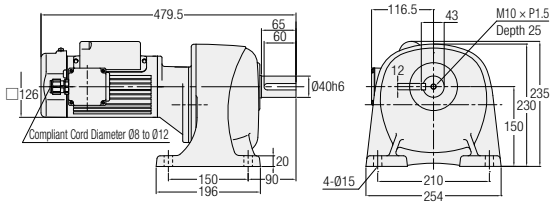

<Figure 2>

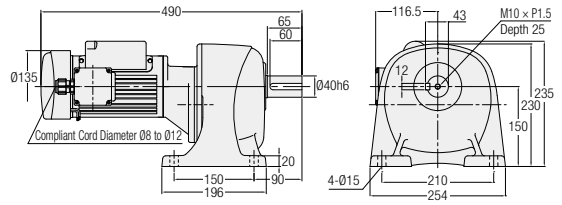

<Figure 3>

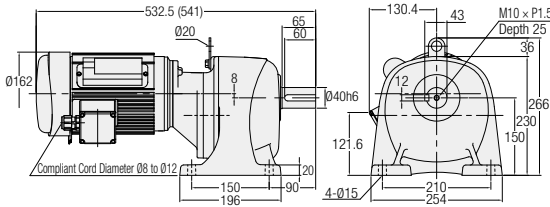

Number of Phases	Power	Part Number	Reduction Ratio	Figure Number	Brake	Approx. Weight (kg)
1-Phase	0.2 kW	G3L40N***-MM02C◇JAN	600, 750, 900, 1200	1	No	22
		G3L40N***-MM02C◇JAB2		2	Yes	23.5
	0.4 kW	G3L40N***-MM04C◇JAN	300, 375, 450	3	No	28.5
		G3L40N***-MM04C◇JAB2		3	Yes	31

Note: A reduction ratio will be indicated as *** in the nomenclature. In addition, a supply voltage code will be indicated as ◇.

Note: Please refer to page 66 for the performance table.

G3 Type Parallel Shaft Shaft Diameter **50** Foot Mounting

The values in parenthesis are those for gearmotors with a brake.

<Figure 1>

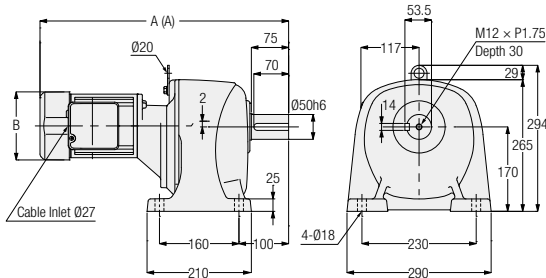

<Figure 2>

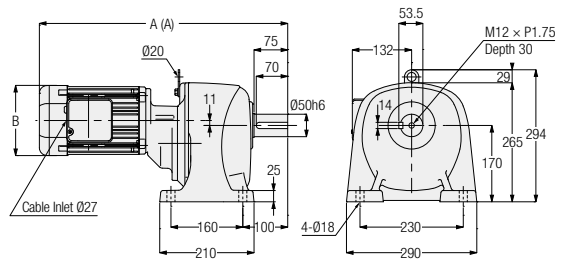

<Figure 3>

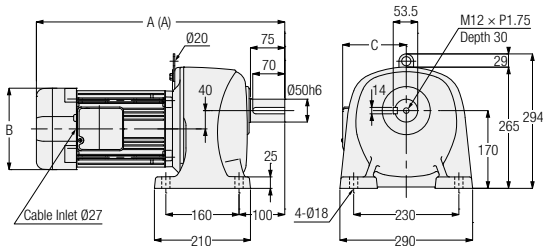

Number of Phases	Power	Part Number	Reduction Ratio	Figure Number	Brake	Approx. Weight (kg)	A	B	C
3-Phase	0.4 kW	G3L50N***-MM04T◇◇TN	600, 750, 900, 1200	1	No	52.5	480.5	□137	-
		Yes			54	500.5	□137	-	
	0.75 kW	G3L50N***-MD08T◇◇TN	300, 375, 450	2	No	60	533	□156	-
		Yes			62.5	553	□156	-	
	1.5 kW	G3L50N***-MD15T◇◇TN	100, 120, 160, 200	3	No	64.5	514	□178	139
		Yes			68	543	□178	139	
2.2 kW	G3L50N***-MD22T◇◇TN	30, 40, 50, 60, 80, 100	3	No	71.5	547.5	□192	149	
	Yes			75	576.5	□192	149		

Note: A reduction ratio will be indicated as *** in the nomenclature. In addition, a supply voltage/certification code will be indicated as ◇◇, and a brake specification will be indicated as ◆.

Note: Please refer to page 64 for the performance table.

G/G3 Type Parallel Shaft

H/H2 Type Right Angle Shaft

F Type Right Angle Hollow Bore/Right Angle Shaft

F2/F3 Type Concentric Right Angle Hollow Bore/Concentric Right Angle Shaft

Technical Documentation

G3 Type Parallel Shaft Shaft Diameter **50** Foot Mounting

The values in parenthesis are those for gearmotors with a brake.

<Figure 1>

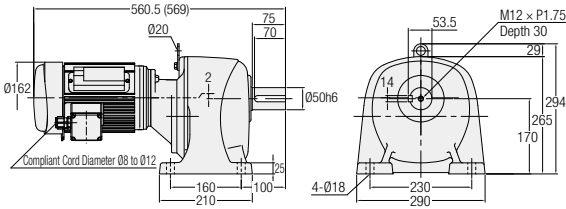

Number of Phases	Power	Part Number	Reduction Ratio	Figure Number	Brake	Approx. Weight (kg)
1-Phase	0.4 kW	G3L50N***-MM04C◇JAN	600, 750, 900, 1200	1	No	58
		G3L50N***-MM04C◇JAB2			Yes	60.5

Note: A reduction ratio will be indicated as *** in the nomenclature. In addition, a supply voltage code will be indicated as ◇.
 Note: Please refer to page 67 for the performance table.

G Type Parallel Shaft Shaft Diameter **12** Flange Mounting

The values in parenthesis are those for gearmotors with a brake.

<Figure 1>

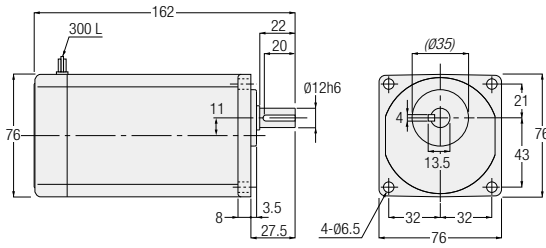

<Figure 2>

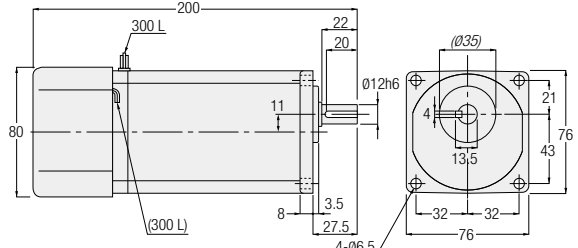

Note: The italic dimension indicates areas with remaining casting surface. Please add 0.5 mm or more to the italic dimension for the diameter of the mating hole.

Number of Phases	Power	Part Number	Reduction Ratio	Figure Number	Brake	Approx. Weight (kg)
3-Phase	15 W	GFM-12-***-T15	5, 7.5, 10, 15, 20, 25, 30, 40, 50, 60, 80, 100, 120, 160, 200, 240	1	No	2
		GFMN-12-***-T15W		2	Yes	2
		GFM-12-***-T15	5, 7.5, 10, 15, 20, 25, 30, 40, 50, 60, 80, 100, 120, 160, 200, 240	1	No	2
		GFMN-12-***-T15W		2	Yes	2
	25 W	GFM-12-***-T25	5, 7.5, 10, 15, 20, 25, 30, 40, 50, 60, 80, 100, 120	1	No	2
		GFMN-12-***-T25W		2	Yes	2
		GFM-12-***-T25	5, 7.5, 10, 15, 20, 25, 30, 40, 50, 60, 80, 100, 120	1	No	2
		GFMN-12-***-T25W		2	Yes	2
	40 W	GFM-12-***-T40	5, 7.5, 10, 15, 20, 25, 30, 40, 50, 60	1	No	2
		GFMN-12-***-T40W		2	Yes	2
		GFM-12-***-T40	5, 7.5, 10, 15, 20, 25, 30, 40, 50, 60	1	No	2
		GFMN-12-***-T40W		2	Yes	2
60 W	GFM-12-***-T60	5, 7.5, 10, 15, 20, 25, 30	2	No	2	
	GFMN-12-***-T60		2	Yes	2	
1-Phase	15 W	GFM-12-***-S15	5, 7.5, 10, 15, 20, 25, 30, 40, 50, 60, 80, 100, 120, 160, 200, 240	1	No	2
		GFMN-12-***-S15W		2	Yes	2
		GFM-12-***-S15	5, 7.5, 10, 15, 20, 25, 30, 40, 50, 60, 80, 100, 120, 160, 200, 240	1	No	2
		GFMN-12-***-S15W		2	Yes	2
	25 W	GFM-12-***-S25	5, 7.5, 10, 15, 20, 25, 30, 40, 50, 60, 80, 100, 120	1	No	2
		GFMN-12-***-S25W		2	Yes	2
		GFM-12-***-S25	5, 7.5, 10, 15, 20, 25, 30, 40, 50, 60, 80, 100, 120	1	No	2
		GFMN-12-***-S25W		2	Yes	2
	40 W	GFM-12-***-S40	5, 7.5, 10, 15, 20, 25, 30, 40, 50, 60	2	No	2
		GFMN-12-***-S40W		2	Yes	2
		GFM-12-***-S40	5, 7.5, 10, 15, 20, 25, 30, 40, 50, 60	2	No	2
		GFMN-12-***-S40W		2	Yes	2

Note: A reduction ratio will be indicated as *** in the nomenclature.

Note: Please refer to page 60 for the performance table.

G/G3 Type Parallel Shaft

H/H2 Type Right Angle Shaft

F Type Right Angle Hollow Bore/ Right Angle Shaft

F2/F3 Type Concentric Right Angle Hollow Bore/ Concentric Right Angle Shaft

Technical Documentation

G Type Parallel Shaft Shaft Diameter **15** **Flange Mounting**

The values in parenthesis are those for gearmotors with a brake.

<Figure 1>

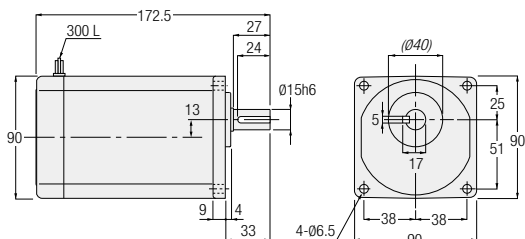

<Figure 2>

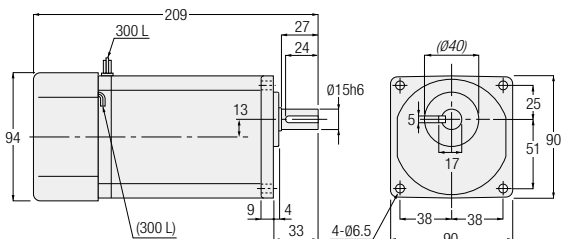

Note: The italic dimension indicates areas with remaining casting surface. Please add 0.5 mm or more to the italic dimension for the diameter of the mating hole.

Number of Phases	Power	Part Number	Reduction Ratio	Figure Number	Brake	Approx. Weight (kg)		
3-Phase	25 W	GFM-15-***-T25	160, 200, 240	1	No	3		
		GFM-15-***-T25W						
		GFMN-15-***-T25	160, 200, 240	2	Yes	3		
		GFMN-15-***-T25W						
3-Phase	40 W	GFM-15-***-T40	80, 100, 120	1	No	3		
		GFM-15-***-T40W						
		GFMN-15-***-T40	80, 100, 120	2	Yes	3		
	GFMN-15-***-T40W							
	3-Phase	60 W	GFM-15-***-T60	40, 50, 60	1	No	3	
			GFM-15-***-T60W	5, 7.5, 10, 15, 20, 25, 30, 40, 50, 60				
GFMN-15-***-T60			40, 50, 60	2	Yes	3		
GFMN-15-***-T60W			5, 7.5, 10, 15, 20, 25, 30, 40, 50, 60					
3-Phase			90 W	GFM-15-***-T90	5, 7.5, 10, 15, 20, 25, 30	1	No	3
				GFM-15-***-T90W	5, 7.5, 10, 15, 20, 25, 30			
	GFMN-15-***-T90	5, 7.5, 10, 15, 20, 25, 30		2	Yes	3		
	GFMN-15-***-T90W	5, 7.5, 10, 15, 20, 25, 30						
1-Phase	25 W	GFM-15-***-S25	160, 200, 240	1	No	3		
		GFM-15-***-S25W						
		GFMN-15-***-S25	160, 200, 240	2	Yes	3		
		GFMN-15-***-S25W						
	1-Phase	40 W	GFM-15-***-S40	80, 100, 120	1	No	3	
			GFM-15-***-S40W					
			GFMN-15-***-S40	80, 100, 120	2	Yes	3	
			GFMN-15-***-S40W					
	1-Phase	60 W	GFM-15-***-S60	5, 7.5, 10, 15, 20, 25, 30, 40, 50, 60	2	No	3	
			GFM-15-***-S60W					
			GFMN-15-***-S60	5, 7.5, 10, 15, 20, 25, 30, 40, 50, 60	2	Yes	3	
			GFMN-15-***-S60W					
1-Phase	90 W	GFM-15-***-S90	5, 7.5, 10, 15, 20, 25, 30	2	No	3		
		GFM-15-***-S90W						
		GFMN-15-***-S90	5, 7.5, 10, 15, 20, 25, 30	2	Yes	3		
		GFMN-15-***-S90W						

Note: A reduction ratio will be indicated as *** in the nomenclature.
Note: Please refer to page 60 for the performance table.

G Type Parallel Shaft Shaft Diameter **18** Flange Mounting

The values in parenthesis are those for gearmotors with a brake.

<Figure 1>

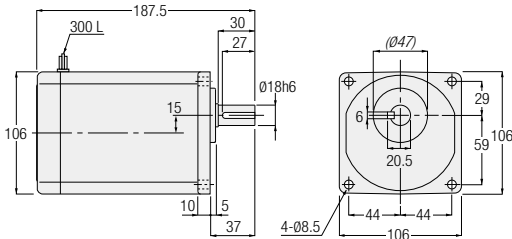

<Figure 2>

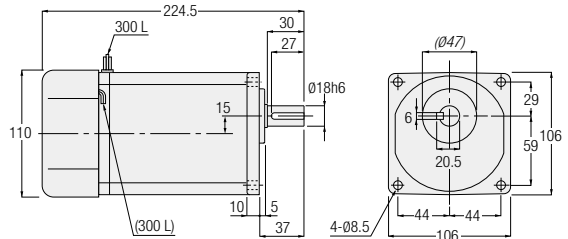

Note: The italic dimension indicates areas with remaining casting surface. Please add 0.5 mm or more to the italic dimension for the diameter of the mating hole.

Number of Phases	Power	Part Number	Reduction Ratio	Figure Number	Brake	Approx. Weight (kg)
3-Phase	40 W	GFM-18-***-T40	160, 200, 240	1	No	4
		GFM-18-***-T40W				
		GFMN-18-***-T40	160, 200, 240	2	Yes	4
		GFMN-18-***-T40W				
	60 W	GFM-18-***-T60	80, 100, 120, 160, 200, 240	1	No	4
		GFM-18-***-T60W				
		GFMN-18-***-T60				
		GFMN-18-***-T60W	80, 100, 120, 160, 200, 240	2	Yes	4
		GFMN-18-***-T60W				
90 W	GFM-18-***-T90	40, 50, 60, 80, 100, 120, 160, 200, 240	1	No	4	
	GFM-18-***-T90W					
	GFMN-18-***-T90	40, 50, 60, 80, 100, 120, 160, 200, 240	2	Yes	4	
GFMN-18-***-T90W						
1-Phase	40 W	GFM-18-***-S40	160, 200, 240	1	No	4
		GFM-18-***-S40W				
		GFMN-18-***-S40	160, 200, 240	2	Yes	4
		GFMN-18-***-S40W				
	60 W	GFM-18-***-S60	80, 100, 120, 160, 200, 240	1	No	4
		GFM-18-***-S60W				
		GFMN-18-***-S60	80, 100, 120, 160, 200, 240	2	Yes	4
		GFMN-18-***-S60W				
	90 W	GFM-18-***-S90	40, 50, 60, 80, 100, 120, 160, 200, 240	2	No	4
		GFM-18-***-S90W				
		GFMN-18-***-S90	40, 50, 60, 80, 100, 120, 160, 200, 240	2	Yes	4
		GFMN-18-***-S90W				

Note: A reduction ratio will be indicated as *** in the nomenclature.
 Note: Please refer to page 61 for the performance table.

G/G3 Type Parallel Shaft

H/H2 Type Right Angle Shaft

F Type Right Angle Hollow Bore/ Right Angle Shaft

F2/F3 Type Concentric Right Angle Hollow Bore/ Concentric Right Angle Shaft

Technical Documentation

G3 Type Parallel Shaft Shaft Diameter **18** **Flange Mounting**

The values in parenthesis are those for gearmotors with a brake.

<Figure 1>

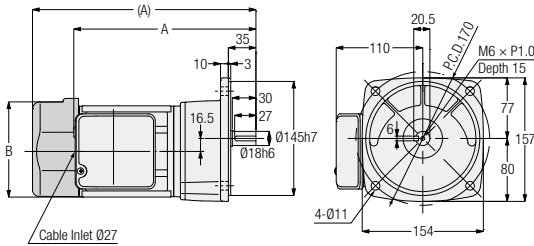

Number of Phases	Power	Part Number	Reduction Ratio	Figure Number	Brake	Approx. Weight (kg)	A	B
3-Phase	0.1 kW	G3F18N***-MM01T◇◇TN	5, 10, 15, 20, 25, 30, 40, 50	1	No	6.5	218.5	Ø115
		Yes			8	258.5	□126	
	0.2 kW	G3F18N***-MM02T◇◇TN	5, 10, 15, 20, 25	1	No	7	233.5	Ø115
		Yes			8.5	284	□126	

Note: A reduction ratio will be indicated as *** in the nomenclature. In addition, a supply voltage/certification code will be indicated as ◇◇, and a brake specification will be indicated as ◆.

Note: Please refer to page 63 for the performance table.

G3 Type Parallel Shaft Shaft Diameter **18** Flange Mounting

The values in parenthesis are those for gearmotors with a brake.

<Figure 1>

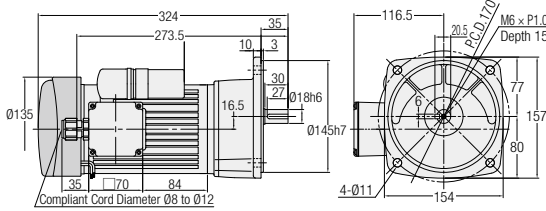

<Figure 2>

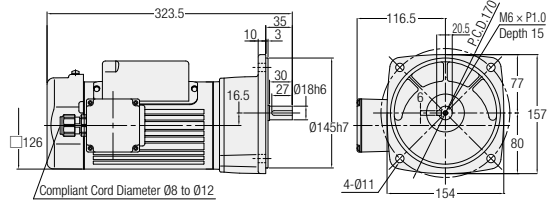

<Figure 3>

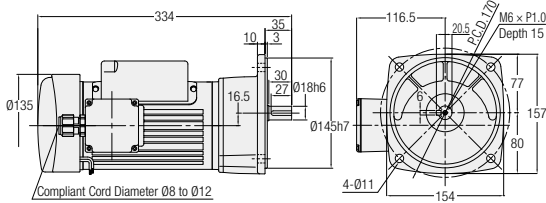

Number of Phases	Power	Part Number	Reduction Ratio	Figure Number	Brake	Approx. Weight (kg)
1-Phase	0.1 kW	G3F18N***-MM01C◇JAN	5, 10, 15, 20, 25, 30, 40, 50	1	No	8
		G3F18N***-MM01C◇JAB2			Yes	9.5
	0.2 kW	G3F18N***-MM02C◇JAN	5, 10, 15, 20, 25	2	No	9
		G3F18N***-MM02C◇JAB2			Yes	10.5

Note: A reduction ratio will be indicated as *** in the nomenclature. In addition, a supply voltage code will be indicated as ◇.
 Note: Please refer to page 66 for the performance table.

G/G3 Type Parallel Shaft

H/H2 Type Right Angle Shaft

F Type Right Angle Hollow Bore/Right Angle Shaft

F2/F3 Type Concentric Right Angle Hollow Bore/Concentric Right Angle Shaft

Technical Documentation

G Type Parallel Shaft

Shaft Diameter **22**

Flange Mounting

The values in parenthesis are those for gearmotors with a brake.

<Figure 1>

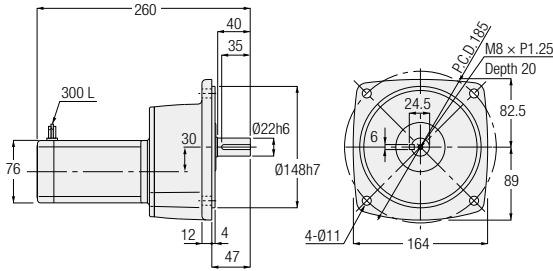

<Figure 2>

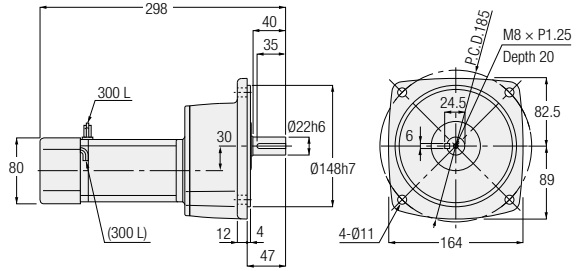

Number of Phases	Power	Part Number	Reduction Ratio	Figure Number	Brake	Approx. Weight (kg)
3-Phase	15 W	GFM-22-***-T15	300, 375, 450, 600, 750, 900, 1200, 1500, 1800	1	No	5
		GFMN-22-***-T15W		2	Yes	5
		GFMN-22-***-T15	300, 375, 450, 600, 750, 900, 1200, 1500, 1800	2	Yes	5
		GFMN-22-***-T15W		2	Yes	5
	25 W	GFM-22-***-T25	300, 375, 450, 600, 750, 900	1	No	5
		GFMN-22-***-T25W		2	Yes	5
		GFMN-22-***-T25	300, 375, 450, 600, 750, 900	2	Yes	5
		GFMN-22-***-T25W		2	Yes	5
40 W	GFM-22-***-T40	300, 375, 450	1	No	5	
	GFMN-22-***-T40W		2	Yes	5	
	GFMN-22-***-T40	300, 375, 450	2	Yes	5	
	GFMN-22-***-T40W		2	Yes	5	
60 W	GFM-22-***-T60	300, 375, 450	2	No	5	
	GFMN-22-***-T60W		2	Yes	5	
	GFMN-22-***-T60	300, 375, 450	2	Yes	5	
	GFMN-22-***-T60W		2	Yes	5	
1-Phase	15 W	GFM-22-***-S15	300, 375, 450, 600, 750, 900, 1200, 1500, 1800	1	No	5
		GFMN-22-***-S15W		2	Yes	5
		GFMN-22-***-S15	300, 375, 450, 600, 750, 900, 1200, 1500, 1800	2	Yes	5
		GFMN-22-***-S15W		2	Yes	5
	25 W	GFM-22-***-S25	300, 375, 450, 600, 750, 900	1	No	5
		GFMN-22-***-S25W		2	Yes	5
		GFMN-22-***-S25	300, 375, 450, 600, 750, 900	2	Yes	5
		GFMN-22-***-S25W		2	Yes	5
	40 W	GFM-22-***-S40	300, 375, 450	2	No	5
		GFMN-22-***-S40W		2	Yes	5
		GFMN-22-***-S40	300, 375, 450	2	Yes	5
		GFMN-22-***-S40W		2	Yes	5
	60 W	GFM-22-***-S60	300, 375, 450	2	No	5
		GFMN-22-***-S60W		2	Yes	5
		GFMN-22-***-S60	300, 375, 450	2	Yes	5
		GFMN-22-***-S60W		2	Yes	5

Note: A reduction ratio will be indicated as *** in the nomenclature.
 Note: Please refer to page 60 for the performance table.

G3 Type Parallel Shaft Shaft Diameter **22** Flange Mounting

The values in parenthesis are those for gearmotors with a brake.

<Figure 1>

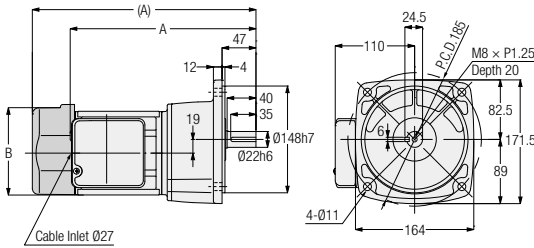

<Figure 2>

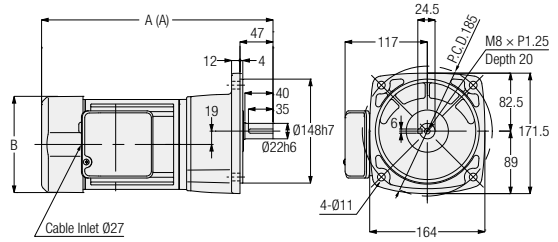

Number of Phases	Power	Part Number	Reduction Ratio	Figure Number	Brake	Approx. Weight (kg)	A	B
3-Phase	0.1 kW	G3F22N***-MM01T◇◇TN	60, 80, 100, 120, 160, 200	1	No	7.5	244.5	Ø115
		G3F22N***-MM01T◇◇TB◆			Yes	9	284.5	□126
	0.2 kW	G3F22N***-MM02T◇◇TN	30, 40, 50, 60, 80, 100	1	No	8	259.5	Ø115
		G3F22N***-MM02T◇◇TB◆			Yes	9.5	310	□126
	0.4 kW	G3F22N***-MM04T◇◇TN	5, 10, 15, 20, 25	2	No	10	309.5	□137
		G3F22N***-MM04T◇◇TB◆			Yes	11.5	329.5	□137

Note: A reduction ratio will be indicated as *** in the nomenclature. In addition, a supply voltage/certification code will be indicated as ◇◇, and a brake specification will be indicated as ◆.

Note: Please refer to page 63 for the performance table.

G/G3 Type Parallel Shaft

H/H2 Type Right Angle Shaft

F Type Right Angle Hollow Bore/Right Angle Shaft

F2/F3 Type Concentric Right Angle Hollow Bore/Concentric Right Angle Shaft

Technical Documentation

G3 Type Parallel Shaft Shaft Diameter **22** Flange Mounting

The values in parenthesis are those for gearmotors with a brake.

<Figure 1>

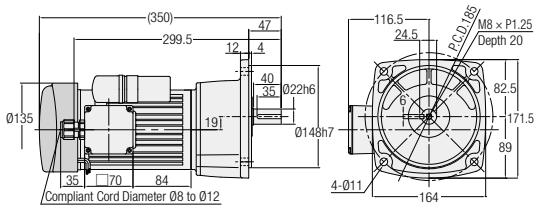

<Figure 2>

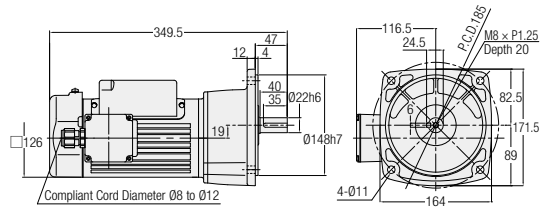

<Figure 3>

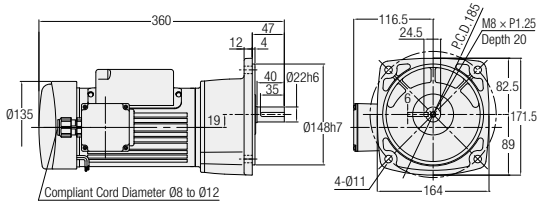

<Figure 4>

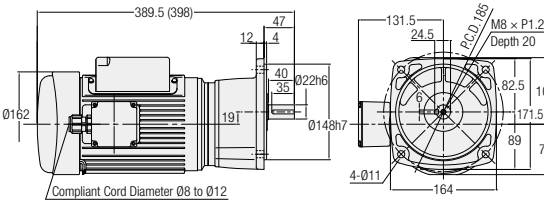

Number of Phases	Power	Part Number	Reduction Ratio	Figure Number	Brake	Approx. Weight (kg)
1-Phase	0.1 kW	G3F22N***-MM01C◇JAN	60, 80, 100, 120, 160, 200	1	No	9
		G3F22N***-MM01C◇JAB2			Yes	10.5
	0.2 kW	G3F22N***-MM02C◇JAN	30, 40, 50, 60, 80, 100	2	No	10
		G3F22N***-MM02C◇JAB2			Yes	11.5
	0.4 kW	G3F22N***-MM04C◇JAN	5, 10, 15, 20, 25	4	No	15.5
		G3F22N***-MM04C◇JAB2			Yes	18

Note: A reduction ratio will be indicated as *** in the nomenclature. In addition, a supply voltage code will be indicated as ◇.
Note: Please refer to page 66 for the performance table.

G Type Parallel Shaft Shaft Diameter **28** Flange Mounting

The values in parenthesis are those for gearmotors with a brake.

<Figure 1>

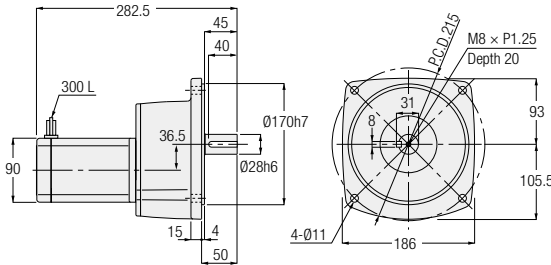

<Figure 2>

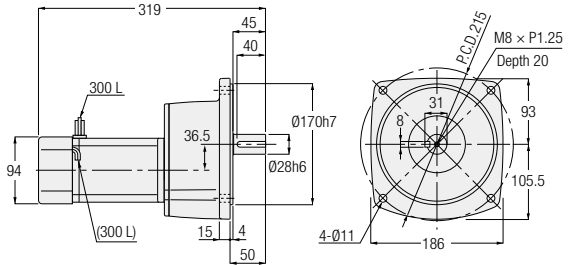

Number of Phases	Power	Part Number	Reduction Ratio	Figure Number	Brake	Approx. Weight (kg)
3-Phase	25 W	GFM-28-***-T25	1200, 1500, 1800	1	No	7
		GFM-28-***-T25W				
		GFMN-28-***-T25	1200, 1500, 1800	2	Yes	7
		GFMN-28-***-T25W				
	40 W	GFM-28-***-T40	600, 750, 900	1	No	7
		GFM-28-***-T40W				
		GFMN-28-***-T40	600, 750, 900	2	Yes	7
		GFMN-28-***-T40W				
	60 W	GFM-28-***-T60	600, 750, 900	1	No	7
		GFM-28-***-T60W				
		GFMN-28-***-T60	600, 750, 900	2	Yes	7
		GFMN-28-***-T60W				
90 W	GFM-28-***-T90	300, 375, 450	1	No	7	
	GFM-28-***-T90W					
	GFMN-28-***-T90	300, 375, 450	2	Yes	7	
	GFMN-28-***-T90W					
1-Phase	25 W	GFM-28-***-S25	1200, 1500, 1800	1	No	7
		GFM-28-***-S25W				
		GFMN-28-***-S25	1200, 1500, 1800	2	Yes	7
		GFMN-28-***-S25W				
	40 W	GFM-28-***-S40	600, 750, 900	2	No	7
		GFM-28-***-S40W				
		GFMN-28-***-S40	600, 750, 900	2	Yes	7
		GFMN-28-***-S40W				
	60 W	GFM-28-***-S60	600, 750, 900	2	No	7
		GFM-28-***-S60W				
		GFMN-28-***-S60	600, 750, 900	2	Yes	7
		GFMN-28-***-S60W				
	90 W	GFM-28-***-S90	300, 375, 450	2	No	7
		GFM-28-***-S90W				
		GFMN-28-***-S90	300, 375, 450	2	Yes	7
		GFMN-28-***-S90W				

Note: A reduction ratio will be indicated as *** in the nomenclature.
 Note: Please refer to page 60 for the performance table.

G/G3 Type Parallel Shaft

H/H2 Type Right Angle Shaft

F Type Right Angle Hollow Bore/ Right Angle Shaft

F2/F3 Type Concentric Right Angle Hollow Bore/ Concentric Right Angle Shaft

Technical Documentation

G3 Type Parallel Shaft **Shaft Diameter 28** **Flange Mounting**

The values in parenthesis are those for gearmotors with a brake.

<Figure 1>

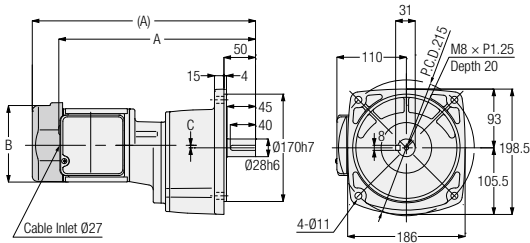

<Figure 2>

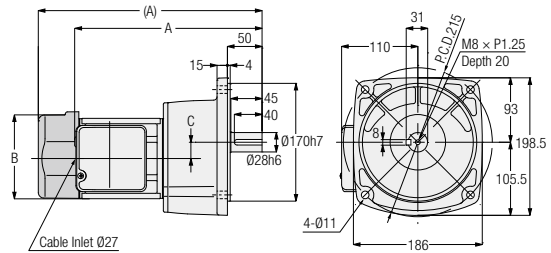

<Figure 3>

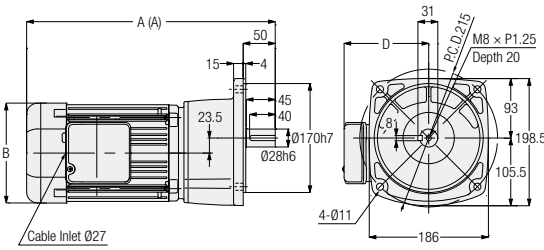

Number of Phases	Power	Part Number	Reduction Ratio	Figure Number	Brake	Approx. Weight (kg)	A	B	C	D
3-Phase	0.1 kW	G3F28N***-MM01T◇◇TN	300, 375, 450	1	No	10.5	313.5	Ø115	4	-
		Yes			12	353.5	□126	4	-	
	0.2 kW	G3F28N***-MM02T◇◇TN	100, 120, 160, 200	2	No	10	272.5	Ø115	23.5	-
		Yes			11.5	323	□126	23.5	-	
	0.4 kW	G3F28N***-MM04T◇◇TN	30, 40, 50, 60, 80, 100	3	No	12	325.5	□137	-	117
		Yes			13.5	345.5	□137	-	117	
0.75 kW	G3F28N***-MD08T◇◇TN	5, 10, 15, 20, 25	3	No	19	368	□156	-	132	
	Yes			21.5	388	□156	-	132		

Note: A reduction ratio will be indicated as *** in the nomenclature. In addition, a supply voltage/certification code will be indicated as ◇◇, and a brake specification will be indicated as ◆.

Note: Please refer to page 63 for the performance table.

G3 Type Parallel Shaft Shaft Diameter **28** Flange Mounting

The values in parenthesis are those for gearmotors with a brake.

<Figure 1>

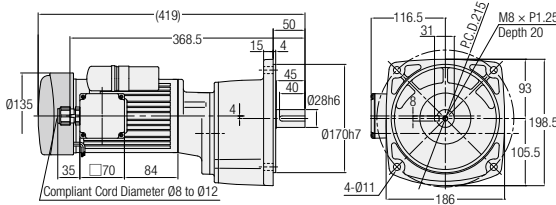

<Figure 2>

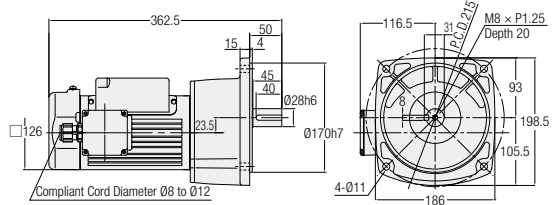

<Figure 3>

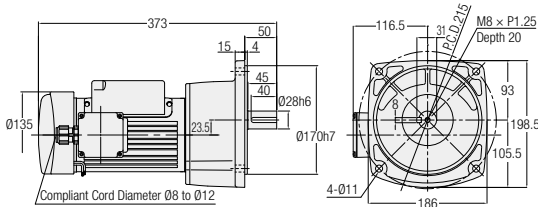

<Figure 4>

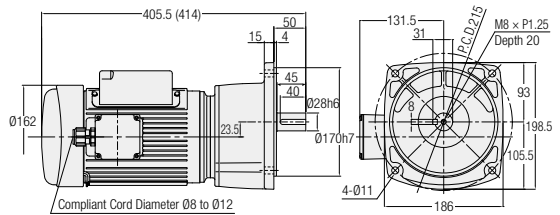

Number of Phases	Power	Part Number	Reduction Ratio	Figure Number	Brake	Approx. Weight (kg)
1-Phase	0.1 kW	G3F28N***-MM01C◇JAN	300, 375, 450	1	No	12
		G3F28N***-MM01C◇JAB2			Yes	13.5
	0.2 kW	G3F28N***-MM02C◇JAN	100, 120, 160, 200	2	No	12
		G3F28N***-MM02C◇JAB2			Yes	13.5
	0.4 kW	G3F28N***-MM04C◇JAN	30, 40, 50, 60, 80, 100	4	No	17.5
		G3F28N***-MM04C◇JAB2			Yes	20

Note: A reduction ratio will be indicated as *** in the nomenclature. In addition, a supply voltage code will be indicated as ◇.

Note: Please refer to page 66 for the performance table.

G/G3 Type Parallel Shaft

H/H2 Type Right Angle Shaft

F Type Right Angle Hollow Bore/ Right Angle Shaft

F2/F3 Type Concentric Right-Angle Hollow Bore/ Concentric Right Angle Shaft

Technical Documentation

G Type Parallel Shaft Shaft Diameter **32** **Flange Mounting**

The values in parenthesis are those for gearmotors with a brake.

<Figure 1>

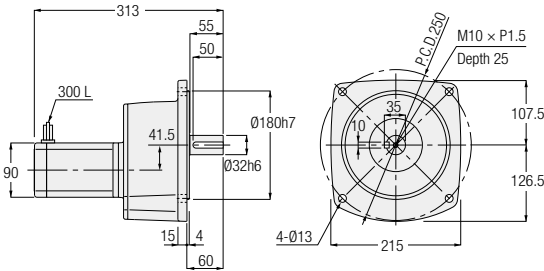

<Figure 2>

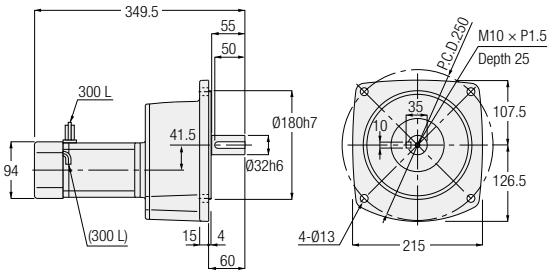

Number of Phases	Power	Part Number	Reduction Ratio	Figure Number	Brake	Approx. Weight (kg)
3-Phase	40 W	GFM-32-***-T40	1200, 1500, 1800	1	No	11
		GFM-32-***-T40W				
		GFMN-32-***-T40	1200, 1500, 1800	2	Yes	11
		GFMN-32-***-T40W				
	60 W	GFM-32-***-T60	1200, 1500, 1800	1	No	11
		GFM-32-***-T60W				
		GFMN-32-***-T60	1200, 1500, 1800	2	Yes	11
		GFMN-32-***-T60W				
	90 W	GFM-32-***-T90	600, 750, 900	1	No	11
		GFM-32-***-T90W		2		
		GFMN-32-***-T90	600, 750, 900	2	Yes	11
		GFMN-32-***-T90W				
1-Phase	40 W	GFM-32-***-S40	1200, 1500, 1800	1	No	11
		GFM-32-***-S40W				
		GFMN-32-***-S40	1200, 1500, 1800	2	Yes	11
		GFMN-32-***-S40W				
	60 W	GFM-32-***-S60	1200, 1500, 1800	2	No	11
		GFM-32-***-S60W				
		GFMN-32-***-S60	1200, 1500, 1800	2	Yes	11
		GFMN-32-***-S60W				
	90 W	GFM-32-***-S90	600, 750, 900	2	No	11
		GFM-32-***-S90W				
		GFMN-32-***-S90	600, 750, 900	2	Yes	11
		GFMN-32-***-S90W				

Note: A reduction ratio will be indicated as *** in the nomenclature.
 Note: Please refer to page 61 for the performance table.

G3 Type Parallel Shaft Shaft Diameter **32** Flange Mounting

The values in parenthesis are those for gearmotors with a brake.

<Figure 1>

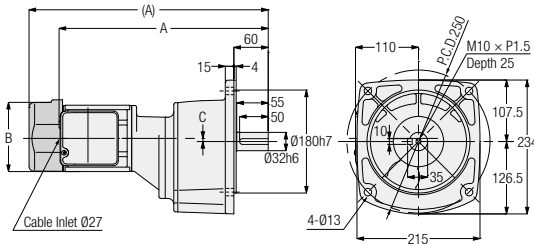

<Figure 2>

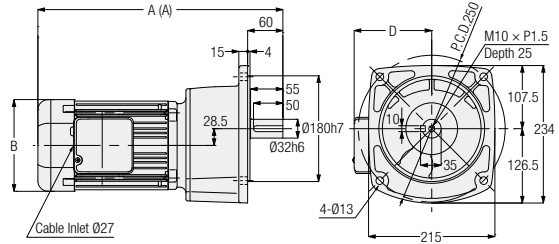

Number of Phases	Power	Part Number	Reduction Ratio	Figure Number	Brake	Approx. Weight (kg)	A	B	C	D
3-Phase	0.1 kW	G3F32N***-MM01T◇◇TN	600, 750, 900, 1200	1	No	13.5	332.5	∅115	-1	-
		Yes			15	372.5	□126	-1	-	
	0.2 kW	G3F32N***-MM02T◇◇TN	300, 375, 450	1	No	14	367.5	∅115	5.5	-
		Yes			15.5	418	□126	5.5	-	
	0.4 kW	G3F32N***-MM04T◇◇TN	100, 120, 160, 200	2	No	15	344.5	□137	-	117
		Yes			16.5	364.5	□137	-	117	
	0.75 kW	G3F32N***-MD08T◇◇TN	30, 40, 50, 60, 80, 100	2	No	22.5	397	□156	-	132
		Yes			25	417	□156	-	132	
	1.5 kW	G3F32N***-MD15T◇◇TN	5, 10, 15, 20, 25	2	No	28.5	449	□178	-	139
		Yes			32	478	□178	-	139	

Note: A reduction ratio will be indicated as *** in the nomenclature. In addition, a supply voltage/certification code will be indicated as ◇◇, and a brake specification will be indicated as ◆.

Note: Please refer to page 63 for the performance table.

G/G3 Type Parallel Shaft

H/H2 Type Right Angle Shaft

F Type Right Angle Hollow Bore/Right Angle Shaft

F2/F3 Type Concentric Right Angle Hollow Bore/Concentric Right Angle Shaft

Technical Documentation

G3 Type Parallel Shaft Shaft Diameter **32** **Flange Mounting**

The values in parenthesis are those for gearmotors with a brake.

<Figure 1>

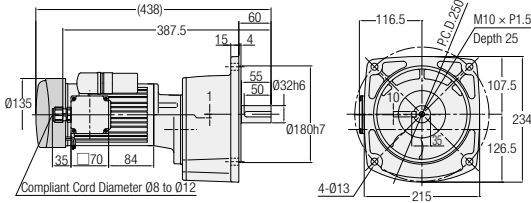

<Figure 2>

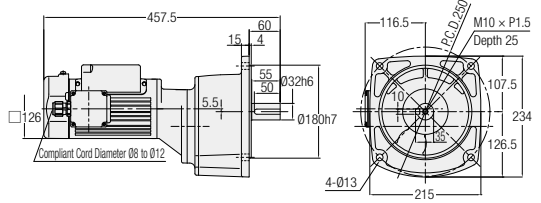

<Figure 3>

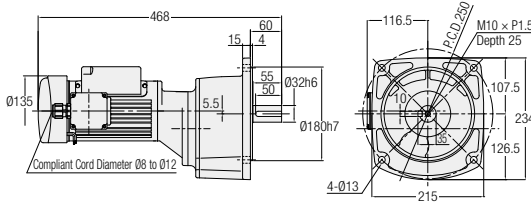

<Figure 4>

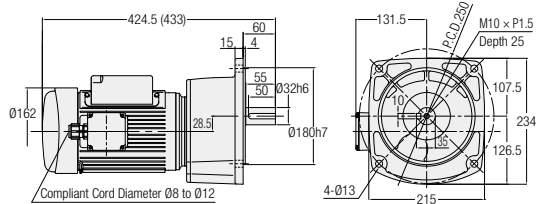

Number of Phases	Power	Part Number	Reduction Ratio	Figure Number	Brake	Approx. Weight (kg)
1-Phase	0.1 kW	G3F32N***-MM01C◇JAN	600, 750, 900, 1200	1	No	15
		G3F32N***-MM01C◇JAB2			Yes	16.5
	0.2 kW	G3F32N***-MM02C◇JAN	300, 375, 450	2	No	16
		G3F32N***-MM02C◇JAB2			Yes	17.5
	0.4 kW	G3F32N***-MM04C◇JAN	100, 120, 160, 200	4	No	20.5
		G3F32N***-MM04C◇JAB2			Yes	23

Note: A reduction ratio will be indicated as *** in the nomenclature. In addition, a supply voltage code will be indicated as ◇.
 Note: Please refer to page 66 for the performance table.

G Type Parallel Shaft Shaft Diameter **40** Flange Mounting

The values in parenthesis are those for gearmotors with a brake.

<Figure 1>

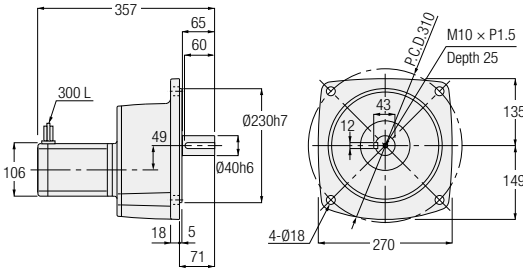

<Figure 2>

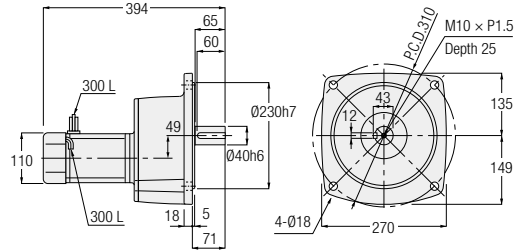

Number of Phases	Power	Part Number	Reduction Ratio	Figure Number	Brake	Approx. Weight (kg)
3-Phase	90 W	GFM-40-***-T90	1200, 1500, 1800	1	No	15
		GFM-40-***-T90W				
		GFMN-40-***-T90	1200, 1500, 1800	2	Yes	15
		GFMN-40-***-T90W				
1-Phase	90 W	GFM-40-***-S90	1200, 1500, 1800	2	No	15
		GFM-40-***-S90W				
		GFMN-40-***-S90	1200, 1500, 1800	2	Yes	15
		GFMN-40-***-S90W				

Note: A reduction ratio will be indicated as *** in the nomenclature.
 Note: Please refer to page 62 for the performance table.

G/G3 Type Parallel Shaft

H/H2 Type Right Angle Shaft

F Type Right Angle Hollow Bore/ Right Angle Shaft

F2/F3 Type Concentric Right Angle Hollow Bore/ Concentric Right Angle Shaft

Technical Documentation

G3 Type Parallel Shaft Shaft Diameter **40** **Flange Mounting**

The values in parenthesis are those for gearmotors with a brake.

<Figure 1>

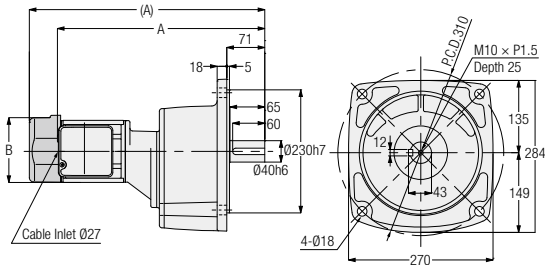

<Figure 2>

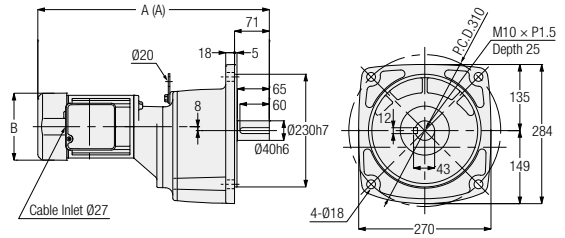

<Figure 3>

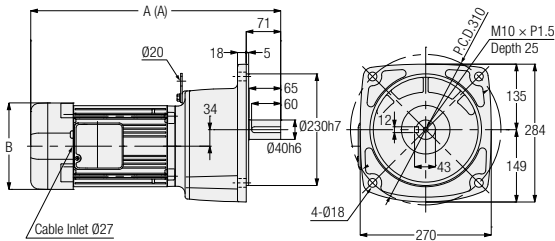

Note: Gearmotors with a motor power of 0.75 kW does not include the hanging plate.

Number of Phases	Power	Part Number	Reduction Ratio	Figure Number	Brake	Approx. Weight (kg)	A	B
3-Phase	0.2 kW	G3F40N***-MM02T◇◇TN	600, 750, 900, 1200	1	No	21.5	389.5	Ø115
		Yes			23	440	□126	
	0.4 kW	G3F40N***-MM04T◇◇TN	300, 375, 450	2	No	24.5	452.5	□137
		Yes			26	472.5	□137	
	0.75 kW	G3F40N***-MD08T◇◇TN	100, 120, 160, 200	3	No	30	419	□156
		Yes			32.5	439	□156	
1.5 kW	G3F40N***-MD15T◇◇TN	30, 40, 50, 60, 80, 100	3	No	36.5	486	□178	
	Yes			40	515	□178		
2.2 kW	G3F40N***-MD22T◇◇TN	5, 10, 15, 20, 25	3	No	43	503.5	□192	
	Yes			46.5	532.5	□192		

Note: A reduction ratio will be indicated as *** in the nomenclature. In addition, a supply voltage/certification code will be indicated as ◇◇, and a brake specification will be indicated as ◆.

Note: Please refer to page 63 for the performance table.

G3 Type Parallel Shaft Shaft Diameter **40** Flange Mounting

<Figure 1>

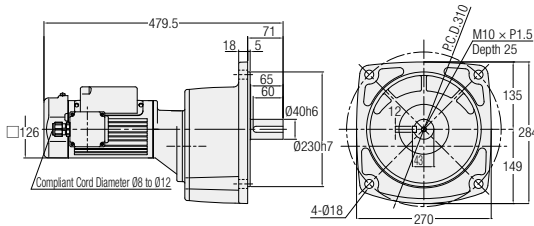

<Figure 2>

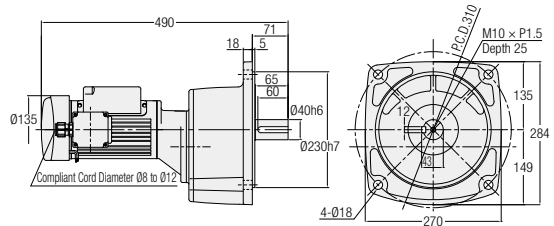

<Figure 3>

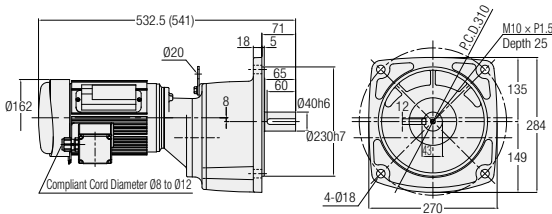

Number of Phases	Power	Part Number	Reduction Ratio	Figure Number	Brake	Approx. Weight (kg)
1-Phase	0.2 kW	G3F40N***-MM02C◇JAN	600, 750, 900, 1200	1	No	23.5
		G3F40N***-MM02C◇JAB2		2	Yes	25
	0.4 kW	G3F40N***-MM04C◇JAN	300, 375, 450	3	No	30
		G3F40N***-MM04C◇JAB2		3	Yes	32.5

Note: A reduction ratio will be indicated as *** in the nomenclature. In addition, a supply voltage code will be indicated as ◇.
 Note: Please refer to page 66 for the performance table.

G/G3 Type Parallel Shaft

H/H2 Type Right Angle Shaft

F Type Right Angle Hollow Bore/ Right Angle Shaft

F2/F3 Type Concentric Right-Angle Hollow Bore/ Concentric Right Angle Shaft

Technical Documentation

G3 Type Parallel Shaft Shaft Diameter **50** **Flange Mounting**

The values in parenthesis are those for gearmotors with a brake.

<Figure 1>

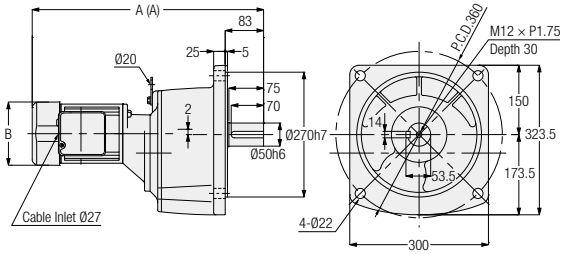

<Figure 2>

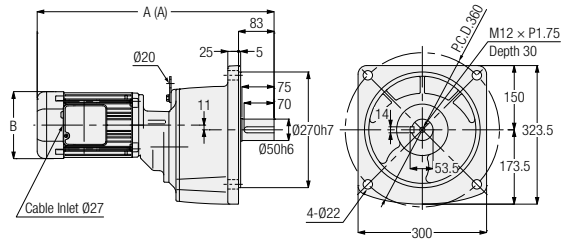

<Figure 3>

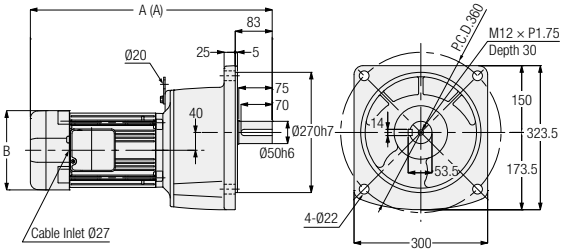

Number of Phases	Power	Part Number	Reduction Ratio	Figure Number	Brake	Approx. Weight (kg)	A	B
3-Phase	0.4 kW	G3F50N***-MM04T◇◇TN	600, 750, 900, 1200	1	No	57.5	480.5	□137
		G3F50N***-MM04T◇◇TB◆			Yes	59	500.5	□137
	0.75 kW	G3F50N***-MD08T◇◇TN	300, 375, 450	2	No	65	533	□156
		G3F50N***-MD08T◇◇TB◆			Yes	67.5	553	□156
	1.5 kW	G3F50N***-MD15T◇◇TN	100, 120, 160, 200	3	No	69.5	514	□178
		G3F50N***-MD15T◇◇TB◆			Yes	73	543	□178
2.2 kW	G3F50N***-MD22T◇◇TN	30, 40, 50, 60, 80, 100	3	No	76.5	547.5	□192	
	G3F50N***-MD22T◇◇TB◆			Yes	80	576.5	□192	

Note: A reduction ratio will be indicated as *** in the nomenclature. In addition, a supply voltage/certification code will be indicated as ◇◇, and a brake specification will be indicated as ◆.

Note: Please refer to page 64 for the performance table.

G3 Type Parallel Shaft Shaft Diameter **50** **Flange Mounting**

The values in parenthesis are those for gearmotors with a brake.

<Figure 1>

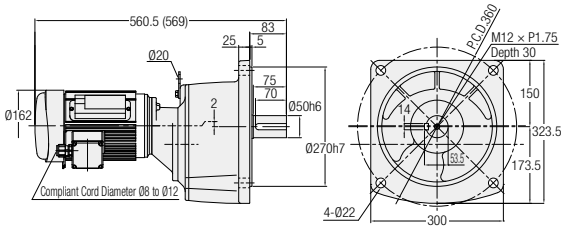

Number of Phases	Power	Part Number	Reduction Ratio	Figure Number	Brake	Approx. Weight (kg)
1-Phase	0.4 kW	G3F50N***-MM04C◇JAN	600, 750, 900, 1200	1	No	63
		G3F50N***-MM04C◇JAB2			Yes	65.5

Note: A reduction ratio will be indicated as *** in the nomenclature. In addition, a supply voltage code will be indicated as ◇.
 Note: Please refer to page 67 for the performance table.

G3 Type Parallel Shaft Shaft Diameter **18** **Small Flange Mounting**

<Figure 2>

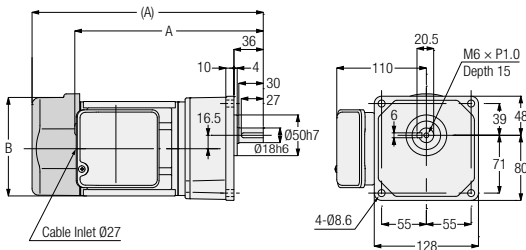

Number of Phases	Power	Part Number	Reduction Ratio	Figure Number	Brake	Approx. Weight (kg)	A	B
3-Phase	0.1 kW	G3K18N***-MM01T◇◇TN	5, 10, 15, 20, 25, 30, 40, 50	2	No	6.5	218.5	Ø115
		G3K18N***-MM01T◇◇TB◆			Yes	8	258.5	□126
	0.2 kW	G3K18N***-MM02T◇◇TN	5, 10, 15, 20, 25	2	No	7	233.5	Ø115
		G3K18N***-MM02T◇◇TB◆			Yes	8.5	284	□126

Note: A reduction ratio will be indicated as *** in the nomenclature. In addition, a supply voltage/certification code will be indicated as ◇◇, and a brake specification will be indicated as ◆.
 Note: Please refer to page 63 for the performance table.

G3 Type Parallel Shaft Shaft Diameter **18** **Small Flange Mounting**

The values in parenthesis are those for gearmotors with a brake.

<Figure 1>

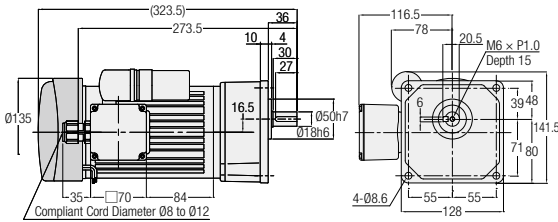

<Figure 2>

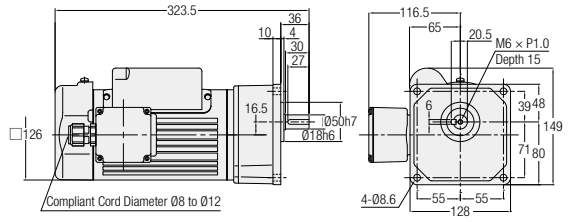

<Figure 3>

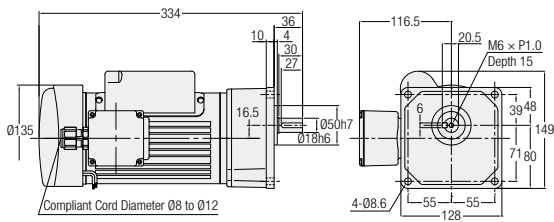

Number of Phases	Power	Part Number	Reduction Ratio	Figure Number	Brake	Approx. Weight (kg)
1-Phase	0.1 kW	G3K18N***-MM01C◇JAN	5, 10, 15, 20, 25, 30, 40, 50	1	No	8
		G3K18N***-MM01C◇JAB2			Yes	9.5
	0.2 kW	G3K18N***-MM02C◇JAN	5, 10, 15, 20, 25	2	No	9
		G3K18N***-MM02C◇JAB2			Yes	10.5

Note: A reduction ratio will be indicated as *** in the nomenclature. In addition, a supply voltage code will be indicated as ◇.
 Note: Please refer to page 66 for the performance table.

G Type Parallel Shaft Shaft Diameter **22** **Small Flange Mounting**

The values in parenthesis are those for gearmotors with a brake.

<Figure 1>

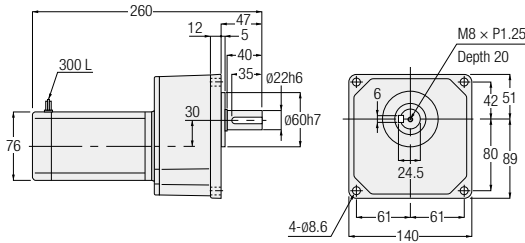

<Figure 2>

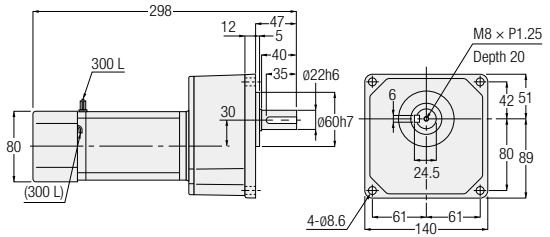

Number of Phases	Power	Part Number	Reduction Ratio	Figure Number	Brake	Approx. Weight (kg)
3-Phase	15 W	GKM-22-***-T15	300, 375, 450, 600, 750, 900, 1200, 1500, 1800	1	No	5
		GKM-22-***-T15W				
		GKMN-22-***-T15	300, 375, 450, 600, 750, 900, 1200, 1500, 1800	2	Yes	5
		GKMN-22-***-T15W				
	25 W	GKM-22-***-T25	300, 375, 450, 600, 750, 900	1	No	5
		GKM-22-***-T25W				
		GKMN-22-***-T25	300, 375, 450, 600, 750, 900	2	Yes	5
		GKMN-22-***-T25W				
	40 W	GKM-22-***-T40	300, 375, 450	1	No	5
		GKM-22-***-T40W				
		GKMN-22-***-T40	300, 375, 450	2	Yes	5
		GKMN-22-***-T40W				
60 W	GKM-22-***-T60	300, 375, 450	2	No	5	
	GKM-22-***-T60W					
	GKMN-22-***-T60	300, 375, 450	2	Yes	5	
	GKMN-22-***-T60W					
1-Phase	15 W	GKM-22-***-S15	300, 375, 450, 600, 750, 900, 1200, 1500, 1800	1	No	5
		GKM-22-***-S15W				
		GKMN-22-***-S15	300, 375, 450, 600, 750, 900, 1200, 1500, 1800	2	Yes	5
		GKMN-22-***-S15W				
	25 W	GKM-22-***-S25	300, 375, 450, 600, 750, 900	1	No	5
		GKM-22-***-S25W				
		GKMN-22-***-S25	300, 375, 450, 600, 750, 900	2	Yes	5
		GKMN-22-***-S25W				
	40 W	GKM-22-***-S40	300, 375, 450	2	No	5
		GKM-22-***-S40W				
		GKMN-22-***-S40	300, 375, 450	2	Yes	5
		GKMN-22-***-S40W				
60 W	GKM-22-***-S60	300, 375, 450	2	No	5	
	GKM-22-***-S60W					
	GKMN-22-***-S60	300, 375, 450	2	Yes	5	
	GKMN-22-***-S60W					

Note: A reduction ratio will be indicated as *** in the nomenclature.
 Note: Please refer to page 60 for the performance table.

G/G3 Type Parallel Shaft

H/H2 Type Right Angle Shaft

F Type Right Angle Hollow Bore/ Right Angle Shaft

F2/F3 Type Concentric Right Angle Hollow Bore/ Concentric Right Angle Shaft

Technical Documentation

G3 Type Parallel Shaft

Shaft Diameter **22**

Small Flange Mounting

The values in parenthesis are those for gearmotors with a brake.

<Figure 1>

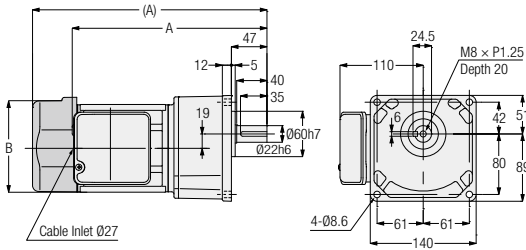

<Figure 2>

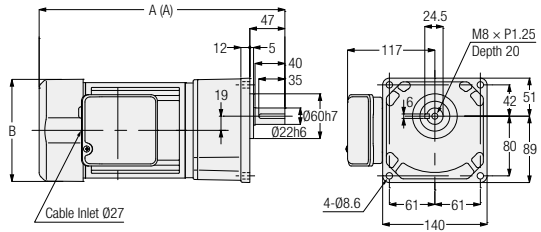

Number of Phases	Power	Part Number	Reduction Ratio	Figure Number	Brake	Approx. Weight (kg)	A	B
3-Phase	0.1 kW	G3K22N***-MM01T◇◇TN	60, 80, 100, 120, 160, 200	1	No	7.5	244.5	∅115
		G3K22N***-MM01T◇◇TB◆			Yes	9	284.5	□126
	0.2 kW	G3K22N***-MM02T◇◇TN	30, 40, 50, 60, 80, 100	1	No	8	259.5	∅115
		G3K22N***-MM02T◇◇TB◆			Yes	9.5	310	□126
	0.4 kW	G3K22N***-MM04T◇◇TN	5, 10, 15, 20, 25	2	No	10	309.5	□137
		G3K22N***-MM04T◇◇TB◆			Yes	11.5	329.5	□137

Note: A reduction ratio will be indicated as *** in the nomenclature. In addition, a supply voltage/certification code will be indicated as ◇◇, and a brake specification will be indicated as ◆.

Note: Please refer to page 63 for the performance table.

G3 Type Parallel Shaft Shaft Diameter **22** Small Flange Mounting

The values in parenthesis are those for gearmotors with a brake.

<Figure 1>

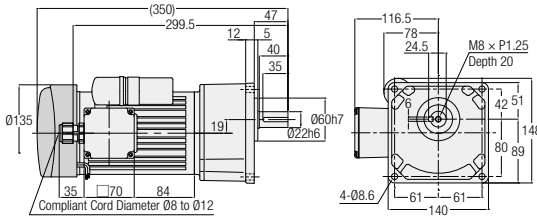

<Figure 2>

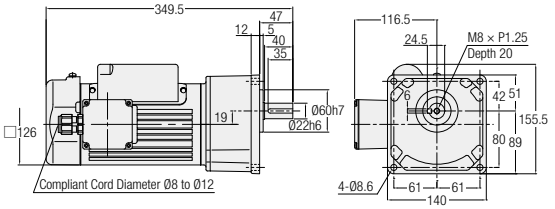

<Figure 3>

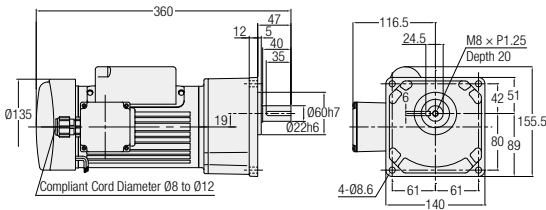

<Figure 4>

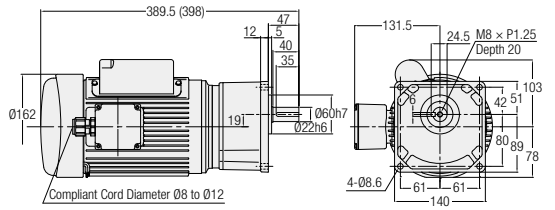

Number of Phases	Power	Part Number	Reduction Ratio	Figure Number	Brake	Approx. Weight (kg)
1-Phase	0.1 kW	G3K22N***-MM01C◇JAN	60, 80, 100, 120, 160, 200	1	No	9
		G3K22N***-MM01C◇JAB2			Yes	10.5
	0.2 kW	G3K22N***-MM02C◇JAN	30, 40, 50, 60, 80, 100	2	No	10
		G3K22N***-MM02C◇JAB2			Yes	11.5
	0.4 kW	G3K22N***-MM04C◇JAN	5, 10, 15, 20, 25	4	No	15.5
		G3K22N***-MM04C◇JAB2			Yes	18

Note: A reduction ratio will be indicated as *** in the nomenclature. In addition, a supply voltage code will be indicated as ◇.
 Note: Please refer to page 66 for the performance table.

G/G3 Type Parallel Shaft

H/H2 Type Right Angle Shaft

F Type Right Angle Hollow Bore/ Right Angle Shaft

F2/F3 Type Concentric Right Angle Hollow Bore/ Concentric Right Angle Shaft

Technical Documentation

G Type Parallel Shaft

Shaft Diameter **28**

Small Flange Mounting

The values in parenthesis are those for gearmotors with a brake.

<Figure 1>

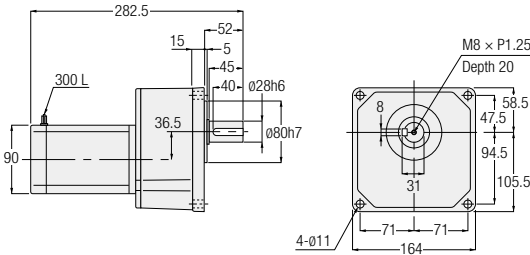

<Figure 2>

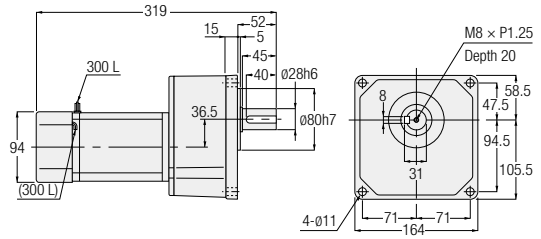

Number of Phases	Power	Part Number	Reduction Ratio	Figure Number	Brake	Approx. Weight (kg)
3-Phase	25 W	GKM-28-***-T25	1200, 1500, 1800	1	No	7
		GKM-28-***-T25W				
		GKMN-28-***-T25	1200, 1500, 1800	2	Yes	7
		GKMN-28-***-T25W				
	40 W	GKM-28-***-T40	600, 750, 900	1	No	7
		GKM-28-***-T40W				
		GKMN-28-***-T40	600, 750, 900	2	Yes	7
	60 W	GKMN-28-***-T40W				
GKM-28-***-T60		600, 750, 900	1	No	7	
GKM-28-***-T60W						
90 W	GKMN-28-***-T60	600, 750, 900	2	Yes	7	
	GKMN-28-***-T60W					
	GKM-28-***-T90	300, 375, 450	1	No	7	
1-Phase	25 W	GKM-28-***-T90W		2	Yes	7
		GKMN-28-***-T90	300, 375, 450	2	Yes	7
		GKMN-28-***-T90W				
		GKM-28-***-S25	1200, 1500, 1800	1	No	7
	40 W	GKM-28-***-S25W				
		GKMN-28-***-S25	1200, 1500, 1800	2	Yes	7
		GKMN-28-***-S25W				
		GKM-28-***-S40	600, 750, 900	1	No	7
	60 W	GKM-28-***-S40W				
		GKMN-28-***-S40	600, 750, 900	2	Yes	7
		GKMN-28-***-S40W				
		GKM-28-***-S60	600, 750, 900	2	No	7
90 W	GKM-28-***-S60W					
	GKMN-28-***-S60	600, 750, 900	2	Yes	7	
	GKMN-28-***-S60W					
	GKM-28-***-S90	300, 375, 450	2	No	7	
90 W	GKM-28-***-S90W					
	GKMN-28-***-S90	300, 375, 450	2	Yes	7	
	GKMN-28-***-S90W					

Note: A reduction ratio will be indicated as *** in the nomenclature.
 Note: Please refer to page 60 for the performance table.

G3 Type Parallel Shaft Shaft Diameter **28** **Small Flange Mounting**

The values in parenthesis are those for gearmotors with a brake.

<Figure 1>

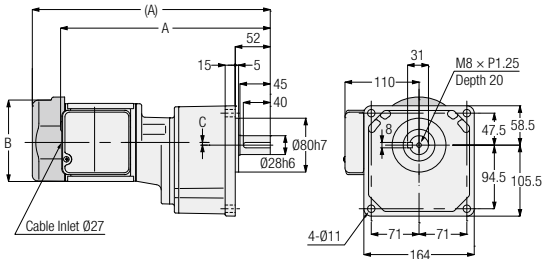

<Figure 2>

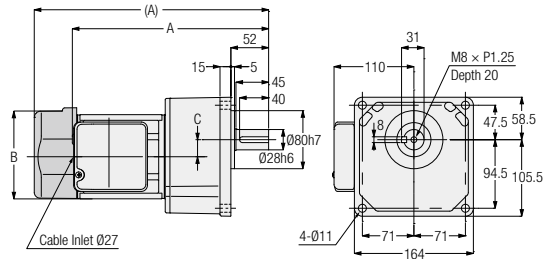

<Figure 3>

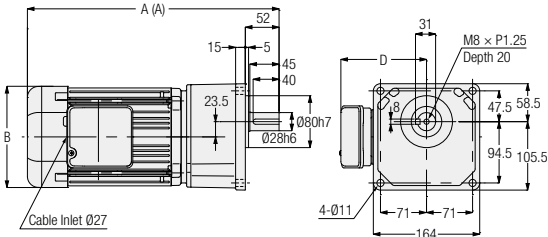

Number of Phases	Power	Part Number	Reduction Ratio	Figure Number	Brake	Approx. Weight (kg)	A	B	C	D
3-Phase	0.1 kW	G3K28N***-MM01T◇◇TN	300, 375, 450	1	No	10.5	313.5	∅115	4	-
		Yes			12	353.5	□126	4	-	
	0.2 kW	G3K28N***-MM02T◇◇TN	100, 120, 160, 200	2	No	10	272.5	∅115	23.5	-
		Yes			11.5	323	□126	23.5	-	
	0.4 kW	G3K28N***-MM04T◇◇TN	30, 40, 50, 60, 80, 100	3	No	12	325.5	□137	-	117
		Yes			13.5	345.5	□137	-	117	
0.75 kW	G3K28N***-MD08T◇◇TN	5, 10, 15, 20, 25	3	No	19	368	□156	-	132	
	Yes			22.5	388	□156	-	132		

Note: A reduction ratio will be indicated as *** in the nomenclature. In addition, a supply voltage/certification code will be indicated as ◇◇, and a brake specification will be indicated as ◆.

Note: Please refer to page 63 for the performance table.

G/G3 Type Parallel Shaft

H/H2 Type Right Angle Shaft

F Type Right Angle Hollow Bore/Right Angle Shaft

F2/F3 Type Concentric Right Angle Hollow Bore/Concentric Right Angle Shaft

Technical Documentation

G3 Type Parallel Shaft Shaft Diameter **28** **Small Flange Mounting**

The values in parenthesis are those for gearmotors with a brake.

<Figure 1>

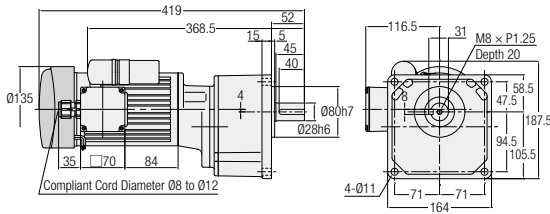

<Figure 2>

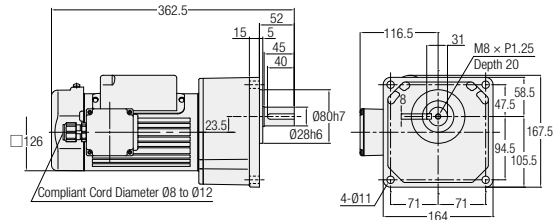

<Figure 3>

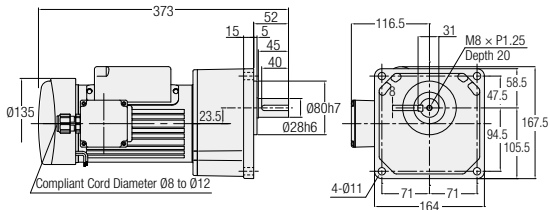

<Figure 4>

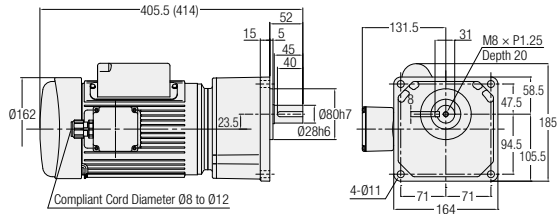

Number of Phases	Power	Part Number	Reduction Ratio	Figure Number	Brake	Approx. Weight (kg)
1-Phase	0.1 kW	G3K28N***-MM01C◇JAN	300, 375, 450	1	No	12
		G3K28N***-MM01C◇JAB2			Yes	13.5
	0.2 kW	G3K28N***-MM02C◇JAN	100, 120, 160, 200	2	No	12
		G3K28N***-MM02C◇JAB2			Yes	13.5
	0.4 kW	G3K28N***-MM04C◇JAN	30, 40, 50, 60, 80, 100	4	No	17.5
		G3K28N***-MM04C◇JAB2			Yes	20

Note: A reduction ratio will be indicated as *** in the nomenclature. In addition, a supply voltage code will be indicated as ◇.
 Note: Please refer to page 66 for the performance table.

G Type Parallel Shaft Shaft Diameter **32** **Small Flange Mounting**

The values in parenthesis are those for gearmotors with a brake.

<Figure 1>

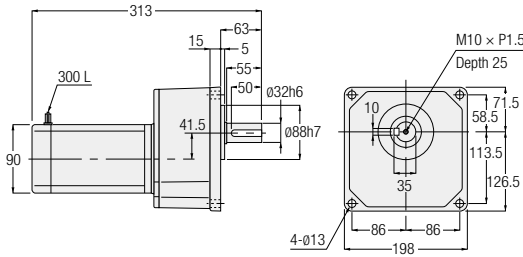

<Figure 2>

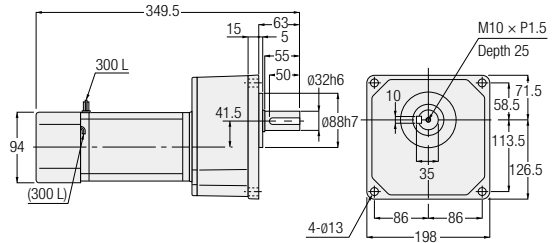

Number of Phases	Power	Part Number	Reduction Ratio	Figure Number	Brake	Approx. Weight (kg)
3-Phase	40 W	GKM-32-***-T40	1200, 1500, 1800	1	No	11
		GKM-32-***-T40W				
		GKMN-32-***-T40	1200, 1500, 1800	2	Yes	11
		GKMN-32-***-T40W				
	60 W	GKM-32-***-T60	1200, 1500, 1800	1	No	11
		GKM-32-***-T60W				
		GKMN-32-***-T60	1200, 1500, 1800	2	Yes	11
	GKMN-32-***-T60W					
	90 W	GKM-32-***-T90	600, 750, 900	1	No	11
GKM-32-***-T90W						
GKMN-32-***-T90		600, 750, 900	2	Yes	11	
GKMN-32-***-T90W						
1-Phase	40 W	GKM-32-***-S40	1200, 1500, 1800	1	No	11
		GKM-32-***-S40W				
		GKMN-32-***-S40	1200, 1500, 1800	2	Yes	11
		GKMN-32-***-S40W				
	60 W	GKM-32-***-S60	1200, 1500, 1800	2	No	11
		GKM-32-***-S60W				
		GKMN-32-***-S60	1200, 1500, 1800	2	Yes	11
	GKMN-32-***-S60W					
	90 W	GKM-32-***-S90	600, 750, 900	2	No	11
		GKM-32-***-S90W				
		GKMN-32-***-S90	600, 750, 900	2	Yes	11
	GKMN-32-***-S90W					

Note: A reduction ratio will be indicated as *** in the nomenclature.
 Note: Please refer to page 61 for the performance table.

G/G3 Type Parallel Shaft

H/H2 Type Right Angle Shaft

F Type Right Angle Hollow Bore/ Right Angle Shaft

F2/F3 Type Concentric Right Angle Hollow Bore/ Concentric Right Angle Shaft

Technical Documentation

G3 Type Parallel Shaft

Shaft Diameter **32**

Small Flange Mounting

The values in parenthesis are those for gearmotors with a brake.

<Figure 1>

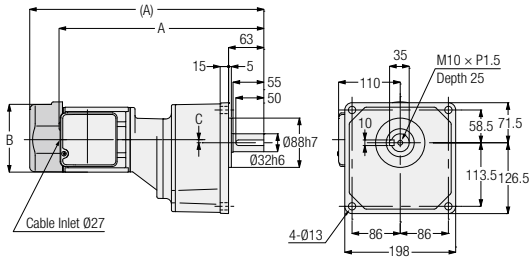

<Figure 2>

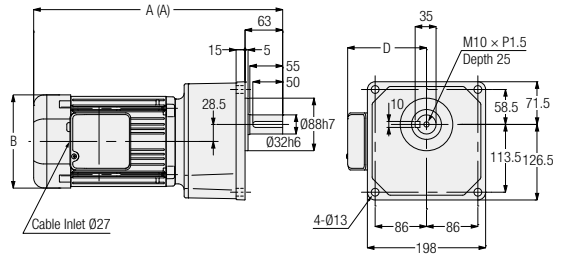

Number of Phases	Power	Part Number	Reduction Ratio	Figure Number	Brake	Approx. Weight (kg)	A	B	C	D
3-Phase	0.1 kW	G3K32N***-MM01T◇◇TN	600, 750, 900, 1200	1	No	13.5	332.5	∅115	-1	-
		Yes			15	372.5	□126	-1	-	
	0.2 kW	G3K32N***-MM02T◇◇TN	300, 375, 450	1	No	14	367.5	∅115	5.5	-
		Yes			15.5	418	□126	5.5	-	
	0.4 kW	G3K32N***-MM04T◇◇TN	100, 120, 160, 200	2	No	15	344.5	□137	-	117
		Yes			16.5	364.5	□137	-	117	
	0.75 kW	G3K32N***-MD08T◇◇TN	30, 40, 50, 60, 80, 100	2	No	22.5	397	□156	-	132
		Yes			25	417	□156	-	132	
	1.5 kW	G3K32N***-MD15T◇◇TN	5, 10, 15, 20, 25	2	No	28.5	449	□178	-	139
		Yes			32	478	□178	-	139	

Note: A reduction ratio will be indicated as *** in the nomenclature. In addition, a supply voltage/certification code will be indicated as ◇◇, and a brake specification will be indicated as ◆.

Note: Please refer to page 63 for the performance table.

G3 Type Parallel Shaft Shaft Diameter **32** **Small Flange Mounting**

The values in parenthesis are those for gearmotors with a brake.

<Figure 1>

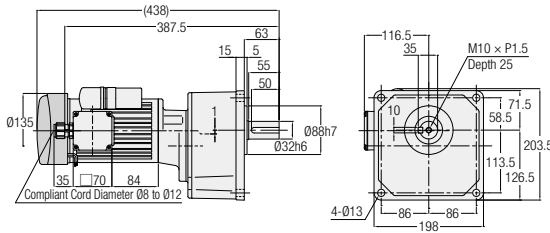

<Figure 2>

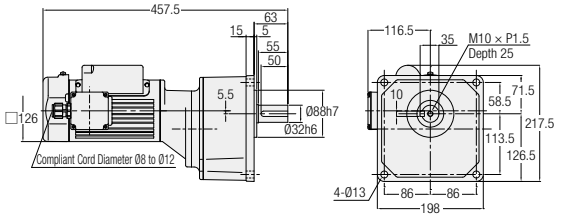

<Figure 3>

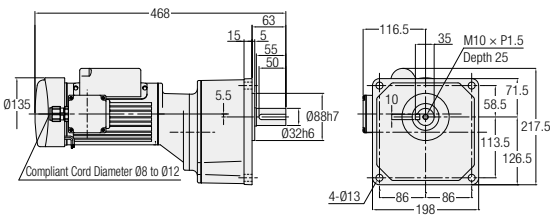

<Figure 4>

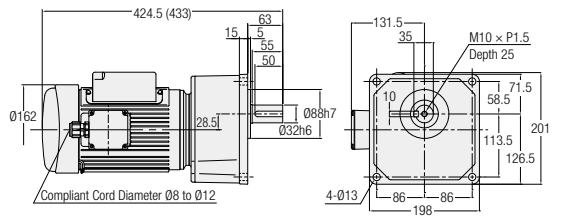

Number of Phases	Power	Part Number	Reduction Ratio	Figure Number	Brake	Approx. Weight (kg)
1-Phase	0.1 kW	G3K32N***-MM01C◇JAN	600, 750, 900, 1200	1	No	15
		G3K32N***-MM01C◇JAB2			Yes	16.5
	0.2 kW	G3K32N***-MM02C◇JAN	300, 375, 450	2	No	16
		G3K32N***-MM02C◇JAB2			Yes	17.5
	0.4 kW	G3K32N***-MM04C◇JAN	100, 120, 160, 200	4	No	20.5
		G3K32N***-MM04C◇JAB2			Yes	23

Note: A reduction ratio will be indicated as *** in the nomenclature. In addition, a supply voltage code will be indicated as ◇.
 Note: Please refer to page 66 for the performance table.

G/G3 Type Parallel Shaft

H/H2 Type Right Angle Shaft

F Type Right Angle Hollow Bore/ Right Angle Shaft

F2/F3 Type Concentric Right Angle Hollow Bore/ Concentric Right Angle Shaft

Technical Documentation

2. IP65 Gearmotors IP65 Gearmotors with Brake

2-1. Motor Characteristics Table

G Type 3-Phase Standard Voltage

Series	Power (W)	Voltage (V)	Frequency (Hz)	Frame Size	Rated Current (A)	Rated Speed (r/min)	Startup Current (A)
MINI	15	200/200/220	50/60/60	12	0.14/0.13/0.13	1350/1550/1600	0.30/0.28/0.31
	25	200/200/220	50/60/60	12	0.21/0.19/0.19	1350/1550/1600	0.44/0.42/0.46
				15	0.18/0.17/0.17	1350/1550/1600	0.43/0.41/0.46
	40	200/200/220	50/60/60	12	0.29/0.27/0.27	1350/1550/1600	0.67/0.62/0.68
				15	0.27/0.26/0.26	1350/1550/1550	0.73/0.69/0.76
				18	0.21/0.21/0.21	1350/1550/1600	0.66/0.64/0.70
	60	200/200/220	50/60/60	15	0.40/0.36/0.36	1350/1550/1600	1.04/0.97/1.07
				18	0.33/0.33/0.33	1350/1550/1600	1.06/1.01/1.11
90	200/200/220	50/60/60	18	0.47/0.47/0.47	1350/1550/1600	1.59/1.51/1.66	

G Type 1-Phase Standard Voltage

Series	Power (W)	Voltage (V)	Frequency (Hz)	Frame Size	Rated Current (A)	Rated Speed (r/min)	Startup Current (A)	Capacitor (μF)
MINI	15	100/100	50/60	12	0.39/0.35	1350/1650	0.72/0.67	5
	25	100/100	50/60	12	0.48/0.48	1350/1600	0.86/0.80	7
				15	0.44/0.45	1350/1650	1.00/0.92	7
	40	100/100	50/60	15	0.61/0.66	1350/1650	1.43/1.36	10
	60	100/100	50/60	18	0.63/0.64	1400/1650	2.16/2.00	10
18				0.90/1.00	1400/1650	2.55/2.37	15	

The rated current in the motor characteristics table is the current data for the motor operating without a gearbox. With regard to gearmotors with a brake, it is necessary to consider the current value flowing through the brake as needed. For more details, please contact your nearest Sales Office or the CS Center.

2-1. Motor Characteristics Table

G Type 3-Phase Standard Voltage/High Voltage (400 V Class)/Special Voltage

Series	Power	Power Supply/ Certification Codes	Voltage (V)	Frequency (Hz)	Rated Current (A)	Startup Current (A)	Rated Speed (r/min)
MID	0.1 kW	NN	200/200/220	50/60/60	0.61/0.54/0.54	2.39/2.27/2.52	1410/1690/1710
		WN	380/400/400/440	50/50/60/60	0.31/0.31/0.28/0.28	1.12/1.18/1.12/1.22	1400/1410/1690/1720
		KN	220/380	60/60	0.52/0.30	1.90/1.10	1680/1680
		CN	220/230/380	50/50/50	0.55/0.54/0.31	1.94/2.03/1.12	1400/1410/1400
		AN	208/230/460/400	60/60/60/50	0.54/0.57/0.29/0.31	2.35/2.62/1.26/1.21	1690/1730/1730/1410
		EN	415/440/480	50/50/60	0.30/0.29/0.26	1.06/1.12/1.17	1390/1420/1720
		MA	575	60	0.20	0.87	1700
	0.2 kW IE2	NN	200/200/220	50/60/60	1.1/1.0/1.0	4.70/4.35/4.85	1400/1680/1700
		WN	380/400/400/440	50/50/60/60	0.56/0.56/0.50/0.50	2.29/2.38/2.29/2.48	1390/1400/1680/1710
		KN	220/380	60/60	0.93/0.52	3.70/2.20	1680/1680
		CN	220/230/380	50/50/50	0.99/0.98/0.56	3.97/4.15/2.29	1400/1410/1390
		AN	208/230/460/400	60/60/60/50	1.0/1.0/0.50/0.56	4.78/5.16/2.56/2.44	1680/1720/1720/1400
		EN	415/440/480	50/50/60	0.50/0.50/0.45	1.75/1.86/2.00	1370/1400/1700
		MA	575	60	0.40	1.78	1710
	0.4 kW IE2	NN	200/200/220	50/60/60	2.1/1.8/1.8	9.50/8.60/9.60	1400/1680/1700
		WN	380/400/400/440	50/50/60/60	1.0/1.0/0.9/0.9	4.35/4.65/4.30/4.75	1390/1400/1680/1710
		KN	220/380	60/60	1.7/1.0	7.10/4.00	1670/1670
		CN	220/230/380	50/50/50	1.8/1.8/1.0	7.53/7.88/4.35	1390/1400/1390
		AN	208/230/460/400	60/60/60/50	1.8/1.8/0.9/1.0	8.90/9.76/4.73/4.78	1680/1720/1720/1400
		EN	415/440/480	50/50/60	0.96/0.95/0.82	3.96/4.20/4.20	1390/1410/1680
		MA	575	60	0.68	3.51	1700
	0.75 kW IE3	NN	200/200/220	50/60/60	3.2/3.0/2.9	19.1/16.6/18.6	1440/1720/1740
		WN	380/400/400/440	50/50/60/60	1.65/1.60/1.50/1.40	9.00/9.60/8.30/9.30	1430/1440/1730/1740
		KN	220/380	60/60	2.8/1.6	17.9/10.8	1750/1750
		CN	220/230/380	50/50/50	2.8/2.7/1.65	15.6/16.3/9.00	1430/1440/1430
		AN	208/230/460/400	60/60/60/50	2.9/2.8/1.4/1.6	18.3/19.6/10.2/10.0	1740/1750/1750/1440
		EN	415/440/480	50/50/60	1.50/1.50/1.35	9.1/9.65/9.70	1440/1450/1750
		MA	575	60	1.10	6.60	1750
	1.5 kW IE3	NN	200/200/220	50/60/60	6.4/6.0/5.7	43.5/36.0/40.3	1450/1740/1750
		WN	380/400/400/440	50/50/60/60	3.3/3.2/3.0/2.9	21.7/23.1/18.6/20.7	1440/1450/1740/1750
		KN	220/380	60/60	5.6/3.2	43.2/24.3	1760/1760
		CN	220/230/380	50/50/50	5.6/5.6/3.3	37.6/39.3/21.7	1450/1460/1440
		AN	208/230/460/400	60/60/60/50	5.9/5.7/2.9/3.2	42.3/45.3/23.0/24.3	1750/1760/1760/1450
		EN	415/440/480	50/50/60	3.0/3.0/2.7	19.8/21.0/18.5	1460/1470/1760
		MA	575	60	2.2	15.3	1760
	2.2 kW IE3	NN	200/200/220	50/60/60	8.8/8.4/7.9	58.5/47.0/52.5	1450/1740/1750
		WN	380/400/400/440	50/50/60/60	4.5/4.4/4.2/3.9	30.0/32.0/25.0/28.0	1440/1450/1740/1750
		KN	220/380	60/60	7.8/4.5	56.4/32.3	1760/1760
		CN	220/230/380	50/50/50	7.9/7.7/4.5	52.0/54.3/30.0	1460/1470/1440
		AN	208/230/460/400	60/60/60/50	8.3/7.9/4.0/4.5	60.8/65.2/34.8/36.3	1750/1770/1770/1470
		EN	415/440/480	50/50/60	4.3/4.3/3.8	33.1/35.5/29.8	1460/1470/1770
		MA	575	60	3.3	24.4	1760

The rated current in the motor characteristics table is the current data for the motor operating without a gearbox. With regard to gearmotors with a brake, it is necessary to consider the current value flowing through the brake as needed. For more details, please contact your nearest Sales Office or the CS Center.

G/G3 Type
Parallel Shaft

H/H2 Type
Right Angle Shaft

F Type
Right Angle Hollow Bore/
Right Angle Shaft

F2/F3 Type
Concentric Right Angle Hollow Bore/
Concentric Right Angle Shaft

Technical Documentation

2-2. Performance Table

G Type IP65 Gearmotors/IP65 Gearmotors with Brake

[Notes]

- The output shaft speed is the value relative to the synchronous speed of the motor and the reduction ratio.
- Allowable output shaft O.H.L. is the value at the middle of the output shaft.
- The “*” mark indicates a limited torque type. Please make sure to check the allowable output shaft torque in the performance table.
- In the performance table, the reduction ratio in [] indicates that when the connection is made as shown on page 506 (CW), the direction of rotation is clockwise in the case of a three-phase motor or counterclockwise in the case of a single-phase motor when viewed from the output shaft side. (Refer to the figure on the right)

3-Phase

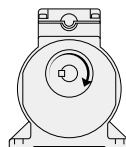

1-Phase

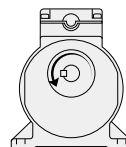

Series	Motor Power	Frame Size	Reduction Ratio	Actual Reduction Ratio	Output Shaft Speed		Allowable Output Shaft Torque	Allowable Output Shaft O.H.L.	Drawings				
					r/min				N·m	N	Foot Mount	Flange Mount	
					50 Hz	60 Hz							
MINI	15 W	12	1/5	1/5	300	360	0.29	98	P.123	P.130			
			1/7.5	1/7.5	200	240	0.49	196					
			1/10	1/10	150	180	0.69	245					
			1/15	1/15	100	120	0.98	343					
			1/20	1/20	75	90	1.27	441					
			1/25	1/25	60	72	1.67	490					
			1/30	1/29	50	60	1.96	539					
			1/40	1/40	37.5	45	2.65	588					
			1/50	1/50	30	36	3.33	637					
			1/60	1/58	25	30	3.92	686					
			1/80	1/80	18.8	22.5	5.00	735					
			1/100	1/100	15	18	6.27	735					
			1/120	1/120	12.5	15	7.45	784					
			1/160	1/160	9.4	11.2	9.80	784					
			1/200	1/200	7.5	9	12.7	784					
			1/240	1/232	6.3	7.5	14.7	784					
	25 W	12	1/5	1/5	300	360	0.59	98	P.123	P.130			
			1/7.5	1/7.5	200	240	0.78	196					
			1/10	1/10	150	180	1.08	245					
			1/15	1/15	100	120	1.67	343					
			1/20	1/20	75	90	2.25	441					
			1/25	1/25	60	72	2.74	490					
			1/30	1/29	50	60	3.33	539					
			1/40	1/40	37.5	45	4.41	588					
			1/50	1/50	30	36	5.49	637					
			1/60	1/58	25	30	6.66	686					
			1/80	1/80	18.8	22.5	8.43	735					
			1/100	1/100	15	18	10.8	735					
			1/120	1/120	12.5	15	12.7	784					
			1/160	1/160	9.4	11.2	16.7	1080					
			1/200	1/200	7.5	9	20.6	1080					
			1/240	1/232	6.3	7.5	25.5	1080					
	40 W	15	1/5	1/5	300	360	0.88	98	P.123	P.130			
			1/7.5	1/7.5	200	240	1.37	196					
			1/10	1/10	150	180	1.76	245					
			1/15	1/15	100	120	2.65	343					
		12	1/20	1/20	75	90	3.53	441	P.123	P.130			
			1/25	1/25	60	72	4.41	490					
			1/30	1/29	50	60	5.29	539					
			1/40	1/40	37.5	45	7.06	588					
			1/50	1/50	30	36	8.82	637					
			1/60	1/58	25	30	10.8	686					
			1/80	1/80	18.8	22.5	13.7	980					
			15	1/100	1/100	15	18	16.7			980	P.123	P.130
				1/120	1/120	12.5	15	20.6			1080		
				1/160	1/160	9.4	11.2	26.5			1370		
				1/200	1/200	7.5	9	33.3			1370		
			18	1/240	1/240	6.3	7.5	40.2			1370	P.124	P.131

2-2. Performance Table

Series	Motor Power	Frame Size	Reduction Ratio	Actual Reduction Ratio	Output Shaft Speed		Allowable Output Shaft Torque	Allowable Output Shaft O.H.L.	Drawings	
					r/min				Foot Mount	Flange Mount
					50 Hz	60 Hz	N·m	N		
MINI	60 W	15	1/5	1/5	300	360	1.37	98	P.123	P.130
			1/7.5	1/7.5	200	240	2.06	196		
			1/10	1/10	150	180	2.74	245		
			1/15	1/15	100	120	4.12	343		
			1/20	1/20	75	90	5.49	441		
			1/25	1/25	60	72	6.96	490		
			1/30	1/29	50	60	8.33	539		
			1/40	1/40	37.5	45	10.8	784		
		1/50	1/50	30	36	13.7	882			
		1/60	1/58	25	30	16.7	882			
		18	1/80	1/80	18.8	22.5	20.6	1270	P.124	P.131
			1/100	1/100	15	18	26.5	1270		
			1/120	1/120	12.5	15	31.4	1370		
			1/160	1/160	9.4	11.2	42.1	1370		
	1/200		1/200	7.5	9	52.9	1370			
	* 1/240		1/240	6.3	7.5	53.9	1370			
	90 W	18	1/5	1/5	300	360	2.06	147	P.124	P.131
			1/7.5	1/7.5	200	240	3.14	245		
			1/10	1/10	150	180	4.12	343		
			1/15	1/15	100	120	6.17	441		
			1/20	1/20	75	90	8.33	539		
			1/25	1/25	60	72	10.8	588		
			1/30	1/29	50	60	12.7	686		
			1/40	1/40	37.5	45	16.7	1080		
			1/50	1/50	30	36	20.6	1180		
			1/60	1/60	25	30	24.5	1180		
			1/80	1/80	18.8	22.5	31.4	1270		
			1/100	1/100	15	18	39.2	1270		
			1/120	1/120	12.5	15	47.0	1370		
			* 1/160	1/160	9.4	11.2	53.9	1370		
			* 1/200	1/200	7.5	9	53.9	1370		
			* 1/240	1/240	6.3	7.5	53.9	1370		

G/G3 Type
Parallel Shaft

H/H2 Type
Right Angle Shaft

F Type
Right Angle Hollow Bore/
Right Angle Shaft

F2/F3 Type
Concentric Right Angle Hollow Bore/
Concentric Right Angle Shaft

Technical Documentation

G3 Type IP65 Gearmotors/IP65 Gearmotors with Brake

[Notes]

- The output shaft speed is the value relative to the synchronous speed of the motor and the reduction ratio.
- in the performance table indicates that the shaft rotates clockwise when viewed from the output shaft side when the connection is made as shown on page 508 (CW). (Refer to the figure on the right)
- Allowable output shaft O.H.L. is the value at the middle of the output shaft.
- The “*” mark indicates a limited torque type. Please make sure to check the allowable output shaft torque in the performance table.

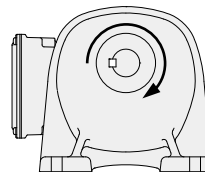

Series	Motor Power	Frame Size	Reduction Ratio	Actual Reduction Ratio	Output Shaft Speed		Allowable Output Shaft Torque		Allowable Output Shaft O.H.L.	Drawings		
					r/min		N·m			Foot Mount	Flange Mount	Small Flange Mount
					50 Hz	60 Hz	50 Hz	60 Hz	N			
MID	3-Phase 0.1 kW	18	1/5	33/164	300	360	3	2.5	770	P.124	P.131	P.137
			1/10	77/779	150	180	6.1	5	1140			
			1/15	119/1804	100	120	9.1	7.5	1270			
			1/20	49/984	75	90	12	9.8	1530			
			1/25	28/697	60	72	15	12.7	1650			
			1/30	35/1066	50	60	19	14.7	1780			
		1/40	35/1404	37.5	45	24	19.6	1910				
		1/50	7/351	30	36	29	24.5	2040				
		1/60	11/684	25	30	35	29.4	2800	P.125	P.132	P.138	
		1/80	21/1634	18.8	22.5	47	39.2	3180				
		1/100	7/684	15	18	59	49	3180				
		1/120	147/17974	12.5	15	71	58.8	3180				
	1/160	21/3268	9.4	11.2	94	78.4	3180					
	1/200	21/4085	7.5	9	117	98	3180					
	1/300	221/65190	5	6	157	130	3430	P.126	P.133	P.139		
	1/375	187/68370	4	4.8	196	163	3430					
	1/450	1183/521520	3.3	4	235	196	3430	P.127	P.134	P.140		
	1/600	147/88192	2.5	3	313	261	5880					
	1/750	49/36464	2	2.4	391	326	5880					
	* 1/900	62/57063	1.7	2	431	391	5880					
	* 1/1200	46/55195	1.3	1.5	431	431	5880	P.124	P.131	P.137		
	1/5	33/164	300	360	6.1	5	770					
	1/10	77/779	150	180	11.8	9.8	1140					
	1/15	119/1804	100	120	18.6	14.7	1270					
1/20	49/984	75	90	24.5	20.6	1450						
1/25	28/697	60	72	30.4	25.5	1550						
1/30	7/216	50	60	36.3	30.4	2280						
1/40	91/3600	37.5	45	47	39.2	2410	P.125				P.132	P.138
1/50	11/540	30	36	58.8	49	2540						
1/60	637/39600	25	30	70.6	58.8	2800						
1/80	91/7200	18.8	22.5	94.1	78.4	3000						
* 1/100	11/1080	15	18	97	80.4	3180	P.126				P.133	P.139
1/100	13/1353	15	18	117	98	3690						
1/120	91/11000	12.5	15	140	117	4320						
1/160	1/165	9.4	11.2	187	156	4450						
1/200	7/1375	7.5	9	234	195	4450	P.127	P.134	P.140			
1/300	91/27348	5	6	313	261	5880						
1/375	77/28620	4	4.8	391	326	5880						
1/450	91/41022	3.3	4	431	391	5880						
1/600	9/5300	2.5	3	626	521	7060	P.128	P.135	-			
* 1/750	62/46427	2	2.4	764	653	7060						
* 1/900	23/21259	1.7	2	764	764	7060						
* 1/1200	9/10600	1.3	1.5	764	764	7060						

2-2. Performance Table

Series	Motor Power	Frame Size	Reduction Ratio	Actual Reduction Ratio	Output Shaft Speed		Allowable Output Shaft Torque		Allowable Output Shaft O.H.L.	Drawings		
					r/min		N·m			Foot Mount	Flange Mount	Small Flange Mount
					50 Hz	60 Hz	50 Hz	60 Hz	N			
MID	3-Phase 0.4 kW	22	1/5	7/34	300	360	12	10	1140	P.125	P.132	P.138
			1/10	7/68	150	180	25	21	1530			
			1/15	49/748	100	120	36	30	1780			
			1/20	7/136	75	90	48	40	1910			
			1/25	7/170	60	72	61	50	2050			
		28	1/30	1/30	50	60	73	61	3310	P.126	P.133	P.139
			1/40	221/8610	37.5	45	94	78	3690			
			1/50	187/9030	30	36	117	98	4080			
			1/60	169/9840	25	30	140	117	4450			
			1/80	65/5166	18.8	22.5	187	156	4450			
		32	* 1/100	55/5418	15	18	193	161	4450	P.127	P.134	P.140
			1/100	7/688	15	18	234	195	6370			
			1/120	77/9360	12.5	15	281	234	7640			
			1/160	21/3328	9.4	11.2	374	313	7640			
		40	1/200	189/38272	7.5	9	431	390	7640	P.128	P.135	-
			1/300	7/2160	5	6	626	521	7060			
			* 1/375	77/29328	4	4.8	764	653	7060			
		50	* 1/450	49/21600	3.3	4	764	764	7060	P.129	P.136	-
			* 1/600	57/35360	2.5	3	1225	1044	9800			
			* 1/750	25/19448	2	2.4	1225	1225	9800			
	* 1/900		5/4338	1.7	2	1225	1225	9800				
	3-Phase 0.75 kW	28	* 1/1200	33/40664	1.3	1.5	1225	1225	9800	P.126	P.133	P.139
			1/5	91/459	300	360	23	19	1650			
			1/10	1/10	150	180	45	38	2280			
			1/15	91/1360	100	120	68	57	2800			
			1/20	5/102	75	90	91	75	3050			
		32	1/25	7/170	60	72	114	94	3180	P.127	P.134	P.140
			1/30	3/92	50	60	136	114	5220			
			1/40	13/516	37.5	45	175	146	5470			
			1/50	11/540	30	36	220	183	5780			
			1/60	13/774	25	30	264	220	6080			
		40	1/80	13/1032	18.8	22.5	351	293	6180	P.128	P.135	-
			* 1/100	11/1080	15	18	362	302	6770			
			1/100	91/9000	15	18	439	366	9170			
			1/120	77/9400	12.5	15	527	439	9170			
		50	1/160	9/1400	9.4	11.2	703	585	9170	P.129	P.136	-
			1/200	9/1750	7.5	9	764	732	9170			
			1/300	211/62013	5	6	1176	978	9800			
			* 1/375	94/36103	4	4.8	1225	1225	9800	P.129	P.136	-
			* 1/450	65/29167	3.3	4	1225	1225	9800			

G/G3 Type
Parallel Shaft

H/H2 Type
Right Angle Shaft

F Type
Right Angle Hollow Bore/
Right Angle Shaft

F2/F3 Type
Concentric Right Angle Hollow Bore/
Concentric Right Angle Shaft

Technical Documentation

Series	Motor Power	Frame Size	Reduction Ratio	Actual Reduction Ratio	Output Shaft Speed		Allowable Output Shaft Torque		Allowable Output Shaft O.H.L. N	Drawings		
					r/min		N·m			Foot Mount	Flange Mount	Small Flange Mount
					50 Hz	60 Hz	50 Hz	60 Hz				
MID	3-Phase 1.5 kW	32	1/5	1/5	300	360	45	38	2280	P.127	P.134	P.140
			1/10	1/10	150	180	91	75	3180			
			1/15	1/15	100	120	136	114	3690			
			1/20	1/20	75	90	181	151	4190			
			1/25	9/230	60	72	226	189	4410			
		40	1/30	1/30	50	60	272	226	6600	P.128	P.135	-
			1/40	13/540	37.5	45	351	293	6960			
			1/50	11/564	30	36	439	366	6960			
			1/60	91/5400	25	30	527	439	7210			
			1/80	13/1080	18.8	22.5	703	585	7400			
			* 1/100	11/1128	15	18	724	603	7400			
			50	1/100	25/2618	15	18	878	732			
	1/120	77/8993		12.5	15	1060	878	12500				
	* 1/160	33/5474		9.4	11.2	1230	1170	12500				
	* 1/200	30/5831		7.5	9	1230	1230	12500				
	1/5	7/36		300	360	67	56	2800				
	3-Phase 2.2 kW	40	1/10	7/72	150	180	133	111	4080	P.128	P.135	-
			1/15	49/720	100	120	200	167	4580			
			1/20	7/144	75	90	266	221	5220			
			1/25	7/180	60	72	332	277	6110			
			1/30	5/154	50	60	399	332	9040			
		50	1/40	399/15488	37.5	45	515	429	9420	P.129	P.136	-
			1/50	399/20240	30	36	644	537	10000			
			1/60	49/2904	25	30	773	644	10000			
1/80			49/3795	18.8	22.5	1029	858	10100				
* 1/100			21/2116	15	18	1230	1080	10100				

Note 1: Please be sure to read the notes on page 120.

2-3. Drawings

G Type Parallel Shaft Shaft Diameter **12** Foot Mounting

The values in parenthesis are those for gearmotors with a brake.

<Figure 1>

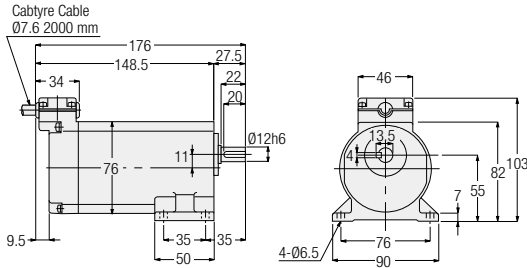

<Figure 2>

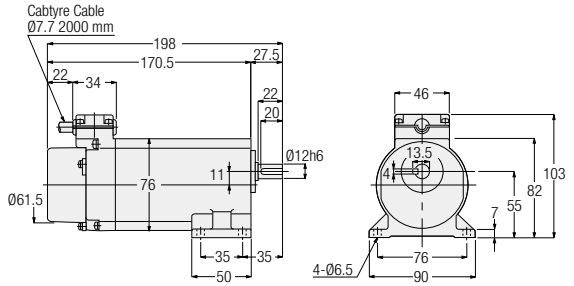

Number of Phases	Power	Part Number	Reduction Ratio	Figure Number	Brake	Approx. Weight (kg)
3-Phase	15 W	GLW-12-***-T15	5, 7.5, 10, 15, 20, 25, 30, 40, 50, 60, 80, 100, 120, 160, 200, 240	1	No	2
		GLV-12-***-T15		2	Yes	
	25 W	GLW-12-***-T25	5, 7.5, 10, 15, 20, 25, 30, 40, 50, 60, 80, 100, 120	1	No	2
		GLV-12-***-T25		2	Yes	
1-Phase	15 W	GLW-12-***-S15	5, 7.5, 10, 15, 20, 25, 30, 40, 50, 60, 80, 100, 120, 160, 200, 240	1	No	2
		GLV-12-***-S15		2	Yes	
	25 W	GLW-12-***-S25	5, 7.5, 10, 15, 20, 25, 30, 40, 50, 60, 80, 100, 120	1	No	2
		GLV-12-***-S25		2	Yes	

Note: A reduction ratio will be indicated as *** in the nomenclature.
Note: Please refer to page 118 for the performance table.

G Type Parallel Shaft Shaft Diameter **15** Foot Mounting

<Figure 3>

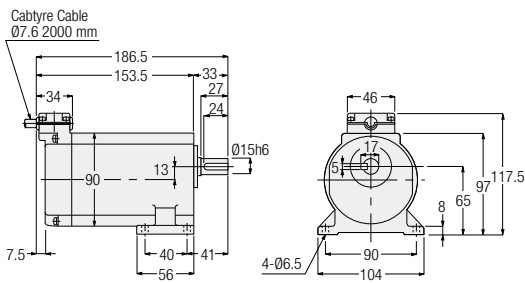

<Figure 4>

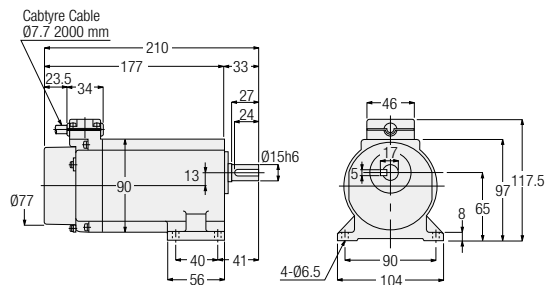

Number of Phases	Power	Part Number	Reduction Ratio	Figure Number	Brake	Approx. Weight (kg)
3-Phase	25 W	GLW-15-***-T25	160, 200, 240	3	No	3
		GLV-15-***-T25		4	Yes	
	40 W	GLW-15-***-T40	80, 100, 120	3	No	3
		GLV-15-***-T40		4	Yes	
	60 W	GLW-15-***-T60	5, 7.5, 10, 15, 20, 25, 30, 40, 50, 60	3	No	3
		GLV-15-***-T60		4	Yes	
1-Phase	25 W	GLW-15-***-S25	160, 200, 240	3	No	3
		GLV-15-***-S25		4	Yes	
	40 W	GLW-15-***-S40	5, 7.5, 10, 15, 20, 25, 30, 40, 50, 60, 80, 100, 120	3	No	3
		GLV-15-***-S40		4	Yes	

Note: A reduction ratio will be indicated as *** in the nomenclature.
Note: Please refer to page 118 for the performance table.

G/G3 Type
Parallel Shaft

H/H2 Type
Right Angle Shaft

F Type
Right Angle Hollow Bore/
Right Angle Shaft

F2/F3 Type
Concentric Right Angle Hollow Bore/
Concentric Right Angle Shaft

Technical Documentation

G Type Parallel Shaft Shaft Diameter **18** Foot Mounting

The values in parenthesis are those for gearmotors with a brake.

<Figure 1>

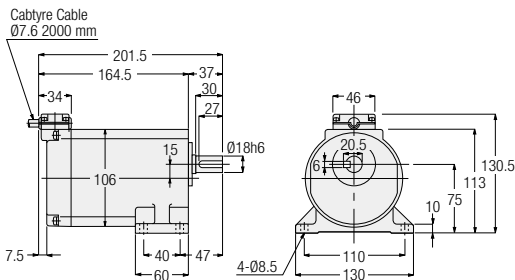

<Figure 2>

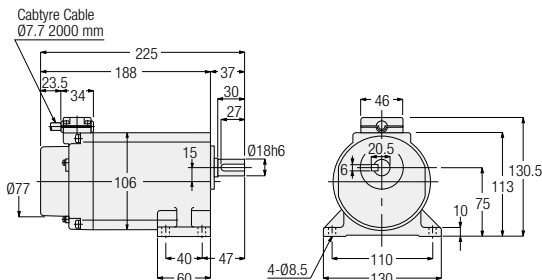

Number of Phases	Power	Part Number	Reduction Ratio	Figure Number	Brake	Approx. Weight (kg)
3-Phase	40 W	GLW-18-***-T40	160, 200, 240	1	No	4
		GLV-18-***-T40		2	Yes	
	60 W	GLW-18-***-T60	80, 100, 120, 160, 200, 240	1	No	4
		GLV-18-***-T60		2	Yes	
1-Phase	40 W	GLW-18-***-S40	160, 200, 240	1	No	4
		GLV-18-***-S40		2	Yes	
	60 W	GLW-18-***-S60	5, 7.5, 10, 15, 20, 25, 30, 40, 50, 60, 80, 100, 120, 160, 200, 240	1	No	4
		GLV-18-***-S60		2	Yes	

Note: A reduction ratio will be indicated as *** in the nomenclature.
Note: Please refer to page 118 for the performance table.

G3 Type Parallel Shaft Shaft Diameter **18** Foot Mounting

<Figure 3>

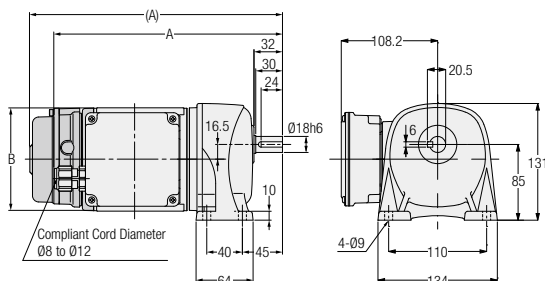

<Figure 4>

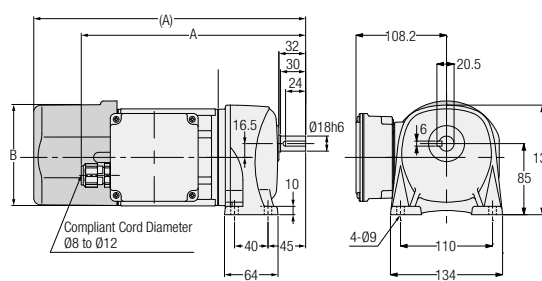

Number of Phases	Power	Output Shaft: Stainless Steel	Output Shaft: Carbon Steel	Reduction Ratio	Figure Number	Brake	Approx. Weight (kg)	A	B
3-Phase	0.1 kW	G3L18S***-WM01T◇◇EN	G3L18N***-WM01T◇◇EN	5, 10, 15, 20, 25, 30, 40, 50	3	No	6	253.5	Ø115
		G3L18S***-WM01T◇◇EV◆	G3L18N***-WM01T◇◇EV◆			Yes	7.5	281	Ø115
	0.2 kW	G3L18S***-WM02T◇◇EN	G3L18N***-WM02T◇◇EN	5, 10, 15, 20, 25	4	No	6.5	268.5	Ø115
		G3L18S***-WM02T◇◇EV◆	G3L18N***-WM02T◇◇EV◆			Yes	8	325	□126

Note: A reduction ratio will be indicated as *** in the nomenclature. In addition, a supply voltage/certification code will be indicated as ◇◇, and a brake specification will be indicated as ◆.

Note: Please refer to page 120 for the performance table.

Note: For the dimensions of the output shaft key, refer to page 869.

Note: The carbon steel output shaft is provided with a tap as a standard specification. Please refer to page 904 for information of the size.

G3 Type Parallel Shaft Shaft Diameter **22** Foot Mounting

The values in parenthesis are those for gearmotors with a brake.

<Figure 1>

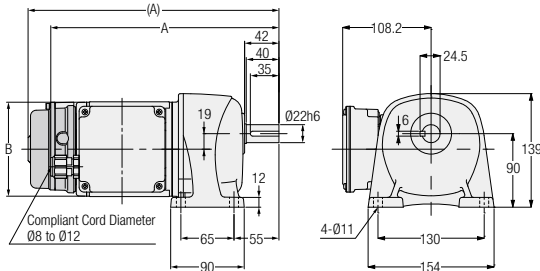

<Figure 2>

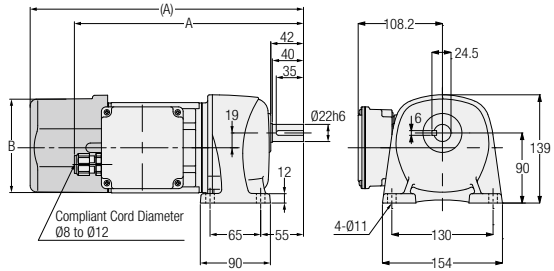

<Figure 3>

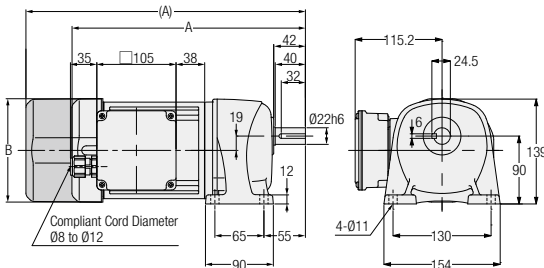

Number of Phases	Power	Output Shaft: Stainless Steel	Output Shaft: Carbon Steel	Reduction Ratio	Figure Number	Brake	Approx. Weight (kg)	A	B
3-Phase	0.1 kW	G3L22S***-WM01T◇◇EN	G3L22N***-WM01T◇◇EN	60, 80, 100, 120, 160, 200	1	No	7	279.5	Ø115
		G3L22S***-WM01T◇◇EV◆	G3L22N***-WM01T◇◇EV◆			Yes	8.5	307	Ø115
	0.2 kW	G3L22S***-WM02T◇◇EN	G3L22N***-WM02T◇◇EN	30, 40, 50, 60, 80, 100	2	No	7.5	294.5	Ø115
		G3L22S***-WM02T◇◇EV◆	G3L22N***-WM02T◇◇EV◆			Yes	9	351	□126
	0.4 kW	G3L22S***-WM04T◇◇EN	G3L22N***-WM04T◇◇EN	5, 10, 15, 20, 25	3	No	9.5	309.5	□137
		G3L22S***-WM04T◇◇EV◆	G3L22N***-WM04T◇◇EV◆			Yes	11	370.5	□137

Note: A reduction ratio will be indicated as *** in the nomenclature. In addition, a supply voltage/certification code will be indicated as ◇◇, and a brake specification will be indicated as ◆.

Note: Please refer to page 120 for the performance table.

Note: For the dimensions of the output shaft key, refer to page 869.

Note: The carbon steel output shaft is provided with a tap as a standard specification. Please refer to page 904 for information of the size.

G/G3 Type Parallel Shaft

H/H2 Type Right Angle Shaft

F Type Right Angle Hollow Bore/Right Angle Shaft

F2/F3 Type Concentric Right Angle Hollow Bore/Concentric Right Angle Shaft

Technical Documentation

G3 Type Parallel Shaft **Shaft Diameter 28** **Foot Mounting**

The values in parenthesis are those for gearmotors with a brake.

<Figure 1>

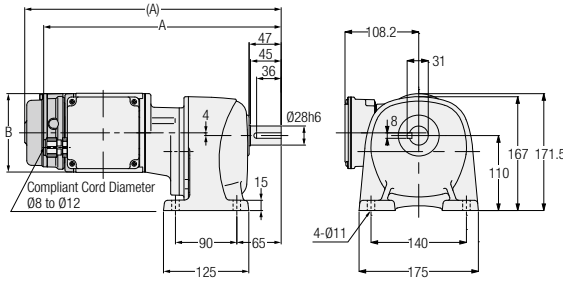

<Figure 2>

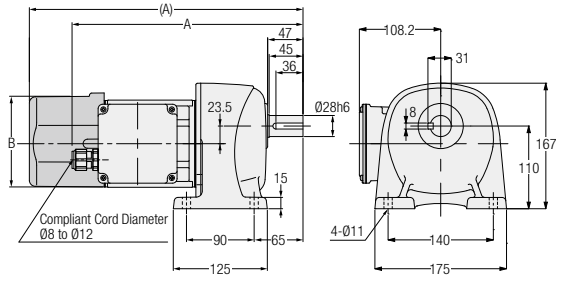

<Figure 3>

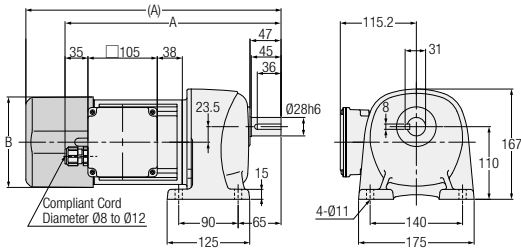

<Figure 4>

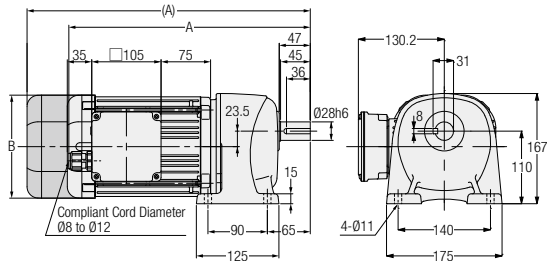

Number of Phases	Power	Output Shaft: Stainless Steel	Output Shaft: Carbon Steel	Reduction Ratio	Figure Number	Brake	Approx. Weight (kg)	A	B
3-Phase	0.1 kW	G3L28S***-WM01T◇◇EN	G3L28N***-WM01T◇◇EN	300, 375, 450	1	No	10	348.5	Ø115
		G3L28S***-WM01T◇◇EV◆	G3L28N***-WM01T◇◇EV◆			Yes	11.5	376	Ø115
	0.2 kW	G3L28S***-WM02T◇◇EN	G3L28N***-WM02T◇◇EN	100, 120, 160, 200	2	No	9.5	307.5	Ø115
		G3L28S***-WM02T◇◇EV◆	G3L28N***-WM02T◇◇EV◆			Yes	11	364	□126
	0.4 kW	G3L28S***-WM04T◇◇EN	G3L28N***-WM04T◇◇EN	30, 40, 50, 60, 80, 100	3	No	11.5	343.5	□137
		G3L28S***-WM04T◇◇EV◆	G3L28N***-WM04T◇◇EV◆			Yes	13	386.5	□137
0.75 kW	G3L28S***-WD08T◇◇EN	G3L28N***-WD08T◇◇EN	5, 10, 15, 20, 25	4	No	18.5	368	□156	
	G3L28S***-WD08T◇◇EV◆	G3L28N***-WD08T◇◇EV◆			Yes	21	429	□156	

Note: A reduction ratio will be indicated as *** in the nomenclature. In addition, a supply voltage/certification code will be indicated as ◇◇, and a brake specification will be indicated as ◆.

Note: Please refer to page 120 for the performance table.

Note: For the dimensions of the output shaft key, refer to page 869.

Note: The carbon steel output shaft is provided with a tap as a standard specification. Please refer to page 904 for information of the size.

G3 Type Parallel Shaft Shaft Diameter **32** Foot Mounting

The values in parenthesis are those for gearmotors with a brake.

<Figure 1>

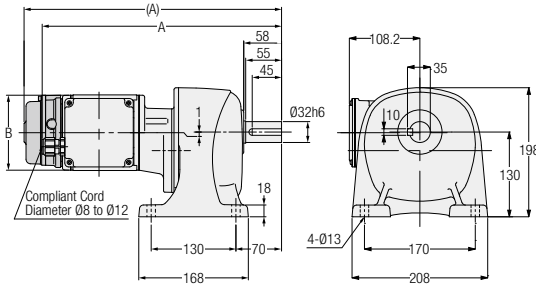

<Figure 2>

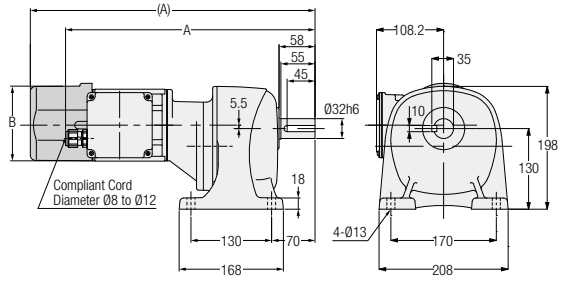

<Figure 3>

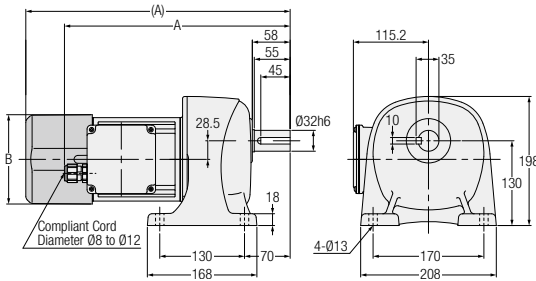

<Figure 4>

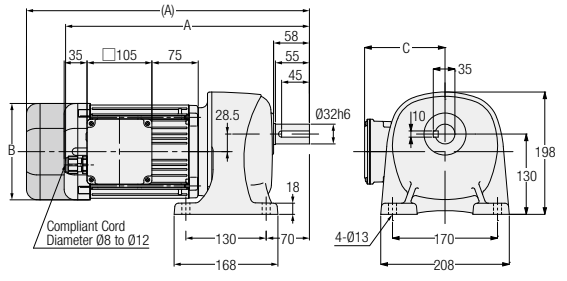

Number of Phases	Power	Output Shaft: Stainless Steel	Output Shaft: Carbon Steel	Reduction Ratio	Figure Number	Brake	Approx. Weight (kg)	A	B	C
3-Phase	0.1 kW	G3L32S***-WM01T◇◇EN	G3L32N***-WM01T◇◇EN	600, 750, 900, 1200	1	No	13	367.5	Ø115	-
		G3L32S***-WM01T◇◇EV◆	G3L32N***-WM01T◇◇EV◆			Yes	14.5	395	Ø115	-
	0.2 kW	G3L32S***-WM02T◇◇EN	G3L32N***-WM02T◇◇EN	300, 375, 450	2	No	13.5	402.5	Ø115	-
		G3L32S***-WM02T◇◇EV◆	G3L32N***-WM02T◇◇EV◆			Yes	15	459	□126	-
	0.4 kW	G3L32S***-WM04T◇◇EN	G3L32N***-WM04T◇◇EN	100, 120, 160, 200	3	No	14.5	344.5	□137	115.2
		G3L32S***-WM04T◇◇EV◆	G3L32N***-WM04T◇◇EV◆			Yes	16	405.5	□137	115.2
0.75 kW	G3L32S***-WD08T◇◇EN	G3L32N***-WD08T◇◇EN	30, 40, 50, 60, 80, 100	4	No	22	397	□156	130.2	
	G3L32S***-WD08T◇◇EV◆	G3L32N***-WD08T◇◇EV◆			Yes	24.5	458	□156	130.2	
1.5 kW	G3L32S***-WD15T◇◇EN	G3L32N***-WD15T◇◇EN	5, 10, 15, 20, 25	4	No	28	449	□178	137.2	

Note: A reduction ratio will be indicated as *** in the nomenclature. In addition, a supply voltage/certification code will be indicated as ◇◇, and a brake specification will be indicated as ◆.

Note: There are no gearmotors with motor power of 1.5 kW that have a brake.

Note: Please refer to page 120 for the performance table.

Note: For the dimensions of the output shaft key, refer to page 869.

Note: The carbon steel output shaft is provided with a tap as a standard specification. Please refer to page 904 for information of the size.

G3 Type Parallel Shaft **Shaft Diameter 40** **Foot Mounting**

The values in parenthesis are those for gearmotors with a brake.

<Figure 1>

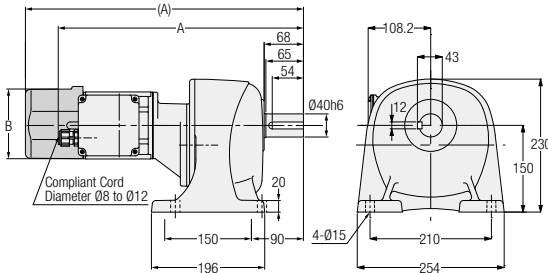

<Figure 2>

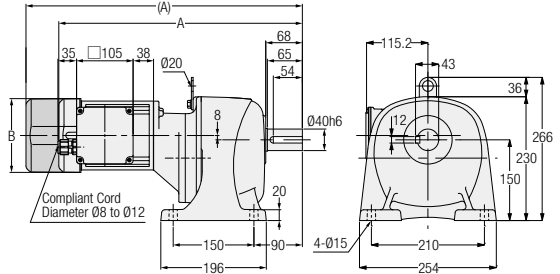

<Figure 3>

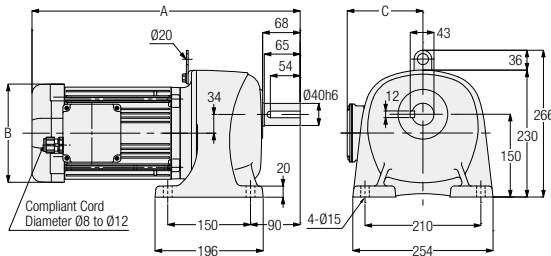

Note: Gearmotors with a motor power of 0.75 kW does not include the hanging plate.

Number of Phases	Power	Output Shaft: Stainless Steel	Output Shaft: Carbon Steel	Reduction Ratio	Figure Number	Brake	Approx. Weight (kg)	A	B	C
3-Phase	0.2 kW	G3L40S***-WM02T◇◇EN	G3L40N***-WM02T◇◇EN	600, 750, 900, 1200	1	No	20	424.5	Ø115	-
		G3L40S***-WM02T◇◇EV◆	G3L40N***-WM02T◇◇EV◆			Yes	21.5	481	□126	-
	0.4 kW	G3L40S***-WM04T◇◇EN	G3L40N***-WM04T◇◇EN	300, 375, 450	2	No	23	452.5	□137	-
		G3L40S***-WM04T◇◇EV◆	G3L40N***-WM04T◇◇EV◆			Yes	24.5	513.5	□137	-
	0.75 kW	G3L40S***-WD08T◇◇EN	G3L40N***-WD08T◇◇EN	100, 120, 160, 200	3	No	28.5	419	□156	130.2
		G3L40S***-WD08T◇◇EV◆	G3L40N***-WD08T◇◇EV◆			Yes	31	480	□156	130.2
1.5 kW	G3L40S***-WD15T◇◇EN	G3L40N***-WD15T◇◇EN	30, 40, 50, 60, 80, 100	3	No	35	486	□178	137.2	
2.2 kW	G3L40S***-WD22T◇◇EN	G3L40N***-WD22T◇◇EN	5, 10, 15, 20, 25	3	No	41.5	503.5	□192	147.2	

Note: A reduction ratio will be indicated as *** in the nomenclature. In addition, a supply voltage/certification code will be indicated as ◇◇, and a brake specification will be indicated as ◆.

Note: There are no gearmotors with motor power of 1.5 kW and 2.2 kW that have a brake.

Note: Please refer to page 120 for the performance table.

Note: For the dimensions of the output shaft key, refer to page 869.

Note: The carbon steel output shaft is provided with a tap as a standard specification. Please refer to page 904 for information of the size.

G3 Type Parallel Shaft Shaft Diameter **50** **Foot Mounting**

The values in parenthesis are those for gearmotors with a brake.

<Figure 1>

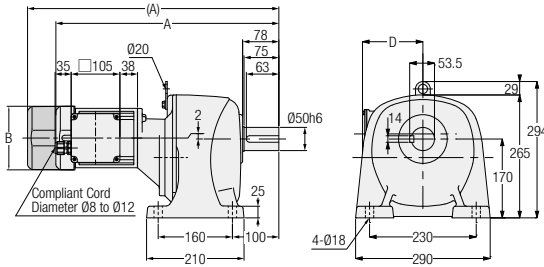

<Figure 2>

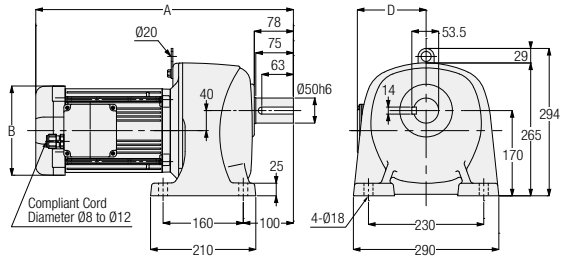

Number of Phases	Power	Output Shaft: Stainless Steel	Output Shaft: Carbon Steel	Reduction Ratio	Figure Number	Brake	Approx. Weight (kg)	A	B	C	D
3-Phase	0.4 kW	G3L50S***-WM04T◇◇EN	G3L50N***-WM04T◇◇EN	600, 750, 900, 1200	1	No	52.5	480.5	□137	2	115.2
		G3L50S***-WM04T◇◇EV◆	G3L50N***-WM04T◇◇EV◆			Yes	54	541.5	□137	2	115.2
	0.75 kW	G3L50S***-WD08T◇◇EN	G3L50N***-WD08T◇◇EN	300, 375, 450	1	No	60	533	□156	11	130.2
		G3L50S***-WD08T◇◇EV◆	G3L50N***-WD08T◇◇EV◆			Yes	62.5	594	□156	11	130.2
	1.5 kW	G3L50S***-WD15T◇◇EN	G3L50N***-WD15T◇◇EN	100, 120, 160, 200	2	No	64.5	514	□178	-	137.2
	2.2 kW	G3L50S***-WD22T◇◇EN	G3L50N***-WD22T◇◇EN	30, 40, 50, 60, 80, 100	2	No	71.5	547.5	□192	-	147.2

Note: A reduction ratio will be indicated as *** in the nomenclature. In addition, a supply voltage/certification code will be indicated as ◇◇, and a brake specification will be indicated as ◆.

Note: There are no gearmotors with motor power of 1.5 kW and 2.2 kW that have a brake.

Note: Please refer to page 121 for the performance table.

Note: For the dimensions of the output shaft key, refer to page 869.

Note: The carbon steel output shaft is provided with a tap as a standard specification. Please refer to page 904 for information of the size.

G/G3 Type Parallel Shaft

H/H2 Type Right Angle Shaft

F Type Right Angle Hollow Bore/Right Angle Shaft

F2/F3 Type Concentric Right Angle Hollow Bore/Concentric Right Angle Shaft

Technical Documentation

G Type Parallel Shaft Shaft Diameter **12** Flange Mounting

The values in parenthesis are those for gearmotors with a brake.

<Figure 1>

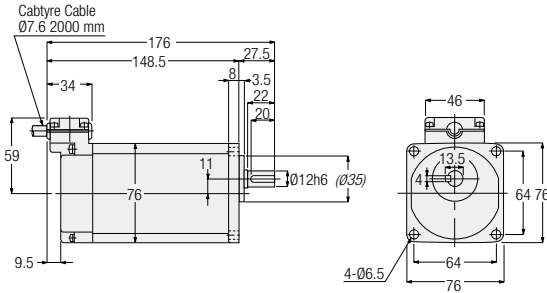

<Figure 2>

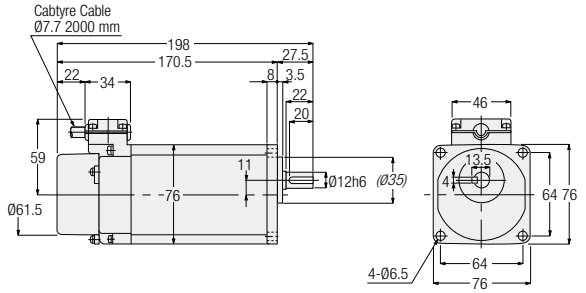

Note: The italic dimension indicates areas with remaining casting surface. Please add 0.5 mm or more to the italic dimension for the diameter of the mating hole.

Number of Phases	Power	Part Number	Reduction Ratio	Figure Number	Brake	Approx. Weight (kg)
3-Phase	15 W	GFW-12-***-T15	5, 7.5, 10, 15, 20, 25, 30, 40, 50, 60, 80, 100, 120, 160, 200, 240	1	No	2
		GFV-12-***-T15		2	Yes	
	25 W	GFW-12-***-T25	5, 7.5, 10, 15, 20, 25, 30, 40, 50, 60, 80, 100, 120	1	No	2
		GFV-12-***-T25		2	Yes	
1-Phase	15 W	GFW-12-***-S15	5, 7.5, 10, 15, 20, 25, 30, 40, 50, 60, 80, 100, 120, 160, 200, 240	1	No	2
		GFV-12-***-S15		2	Yes	
	25 W	GFW-12-***-S25	5, 7.5, 10, 15, 20, 25, 30, 40, 50, 60, 80, 100, 120	1	No	2
		GFV-12-***-S25		2	Yes	

Note: A reduction ratio will be indicated as *** in the nomenclature.
Note: Please refer to page 118 for the performance table.

G Type Parallel Shaft Shaft Diameter **15** Flange Mounting

<Figure 3>

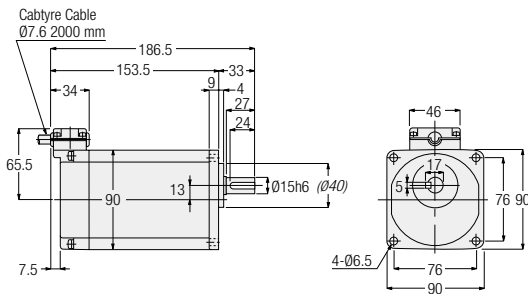

<Figure 4>

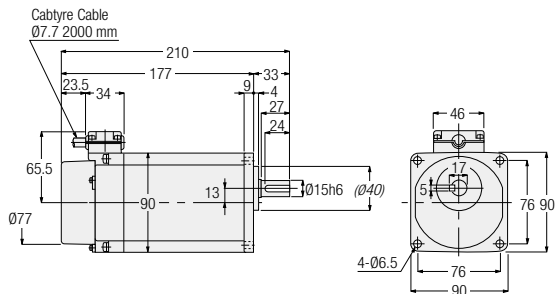

Note: The italic dimension indicates areas with remaining casting surface. Please add 0.5 mm or more to the italic dimension for the diameter of the mating hole.

Number of Phases	Power	Part Number	Reduction Ratio	Figure Number	Brake	Approx. Weight (kg)
3-Phase	25 W	GFW-15-***-T25	160, 200, 240	3	No	3
		GFV-15-***-T25		4	Yes	
	40 W	GFW-15-***-T40	80, 100, 120	3	No	3
		GFV-15-***-T40		4	Yes	
	60 W	GFW-15-***-T60	5, 7.5, 10, 15, 20, 25, 30, 40, 50, 60	3	No	3
		GFV-15-***-T60		4	Yes	
1-Phase	25 W	GFW-15-***-S25	160, 200, 240	3	No	3
		GFV-15-***-S25		4	Yes	
	40 W	GFW-15-***-S40	5, 7.5, 10, 15, 20, 25, 30, 40, 50, 60, 80, 100, 120	3	No	3
		GFV-15-***-S40		4	Yes	

Note: A reduction ratio will be indicated as *** in the nomenclature.
Note: Please refer to page 118 for the performance table.

G Type Parallel Shaft Shaft Diameter **18** Flange Mounting

The values in parenthesis are those for gearmotors with a brake.

<Figure 1>

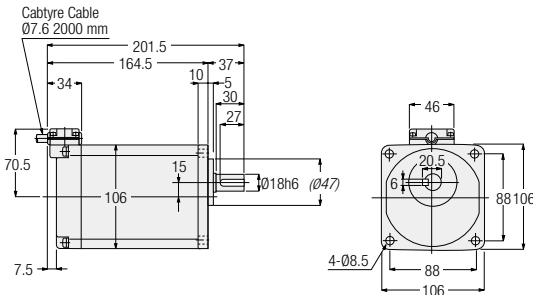

<Figure 2>

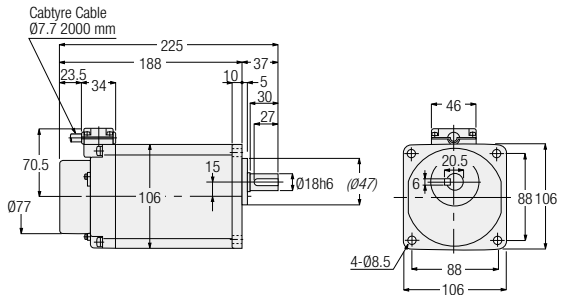

Note: The italic dimension indicates areas with remaining casting surface. Please add 0.5 mm or more to the italic dimension for the diameter of the mating hole.

Number of Phases	Power	Part Number	Reduction Ratio	Figure Number	Brake	Approx. Weight (kg)
3-Phase	40 W	GFW-18-***-T40	160, 200, 240	1	No	4
		GFV-18-***-T40		2	Yes	
	60 W	GFW-18-***-T60	80, 100, 120, 160, 200, 240	1	No	4
		GFV-18-***-T60		2	Yes	
1-Phase	40 W	GFW-18-***-S40	160, 200, 240	1	No	4
		GFV-18-***-S40		2	Yes	
	60 W	GFW-18-***-S60	5, 7.5, 10, 15, 20, 25, 30, 40, 50, 60, 80, 100, 120, 160, 200, 240	1	No	4
		GFV-18-***-S60		2	Yes	

Note: A reduction ratio will be indicated as *** in the nomenclature.
Note: Please refer to page 118 for the performance table.

G3 Type Parallel Shaft Shaft Diameter **18** Flange Mounting

<Figure 3>

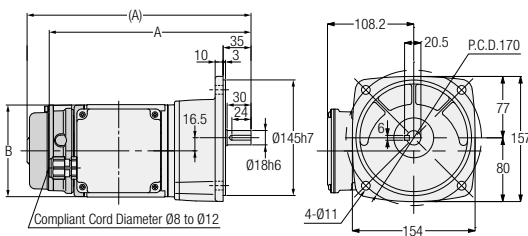

<Figure 4>

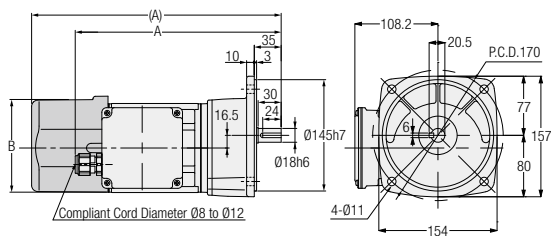

Number of Phases	Power	Output Shaft: Stainless Steel	Output Shaft: Carbon Steel	Reduction Ratio	Figure Number	Brake	Approx. Weight (kg)	A	B
3-Phase	0.1 kW	G3F18S***-WM01T◇◇EN	G3F18N***-WM01T◇◇EN	5, 10, 15, 20, 25, 30, 40, 50	3	No	6.5	253.5	Ø115
		G3F18S***-WM01T◇◇EV◆	G3F18N***-WM01T◇◇EV◆			Yes	8	281	Ø115
	0.2 kW	G3F18S***-WM02T◇◇EN	G3F18N***-WM02T◇◇EN	5, 10, 15, 20, 25	4	No	7	268.5	Ø115
		G3F18S***-WM02T◇◇EV◆	G3F18N***-WM02T◇◇EV◆			Yes	8.5	325	□126

Note: A reduction ratio will be indicated as *** in the nomenclature. In addition, a supply voltage/certification code will be indicated as ◇◇, and a brake specification will be indicated as ◆.
Note: Please refer to page 120 for the performance table.
Note: For the dimensions of the output shaft key, refer to page 869.
Note: The carbon steel output shaft is provided with a tap as a standard specification. Please refer to page 904 for information of the size.

G3 Type Parallel Shaft **Shaft Diameter 22** **Flange Mounting**

The values in parenthesis are those for gearmotors with a brake.

<Figure 1>

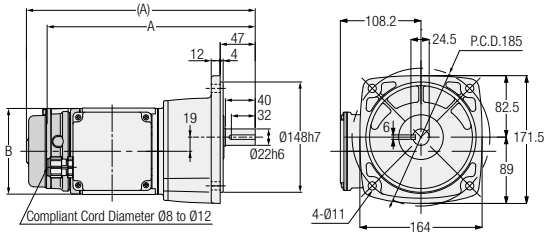

<Figure 2>

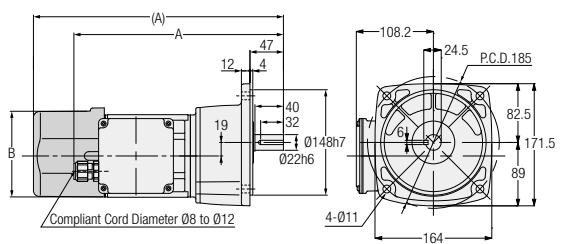

<Figure 3>

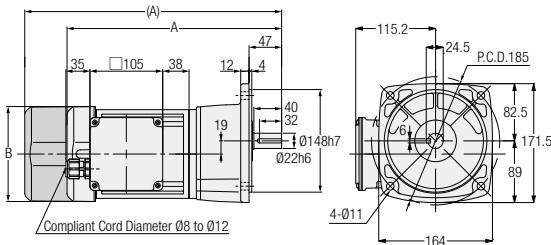

Number of Phases	Power	Output Shaft: Stainless Steel	Output Shaft: Carbon Steel	Reduction Ratio	Figure Number	Brake	Approx. Weight (kg)	A	B
3-Phase	0.1 kW	G3F22S***-WM01T◇◇EN	G3F22N***-WM01T◇◇EN	60, 80, 100, 120, 160, 200	1	No	7.5	279.5	Ø115
		G3F22S***-WM01T◇◇EV◆	G3F22N***-WM01T◇◇EV◆			Yes	9	307	Ø115
	0.2 kW	G3F22S***-WM02T◇◇EN	G3F22N***-WM02T◇◇EN	30, 40, 50, 60, 80, 100	2	No	8	294.5	Ø115
		G3F22S***-WM02T◇◇EV◆	G3F22N***-WM02T◇◇EV◆			Yes	9.5	351	□126
	0.4 kW	G3F22S***-WM04T◇◇EN	G3F22N***-WM04T◇◇EN	5, 10, 15, 20, 25	3	No	10	309.5	□137
		G3F22S***-WM04T◇◇EV◆	G3F22N***-WM04T◇◇EV◆			Yes	11.5	370.5	□137

Note: A reduction ratio will be indicated as *** in the nomenclature. In addition, a supply voltage/certification code will be indicated as ◇◇, and a brake specification will be indicated as ◆.

Note: Please refer to page 120 for the performance table.

Note: For the dimensions of the output shaft key, refer to page 869.

Note: The carbon steel output shaft is provided with a tap as a standard specification. Please refer to page 904 for information of the size.

G3 Type Parallel Shaft Shaft Diameter 28 Flange Mounting

The values in parenthesis are those for gearmotors with a brake.

<Figure 1>

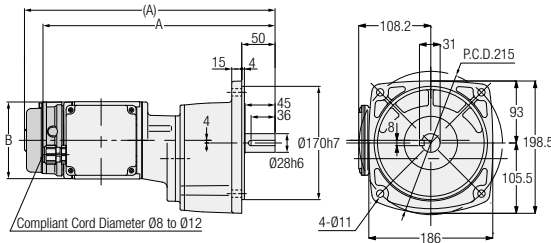

<Figure 2>

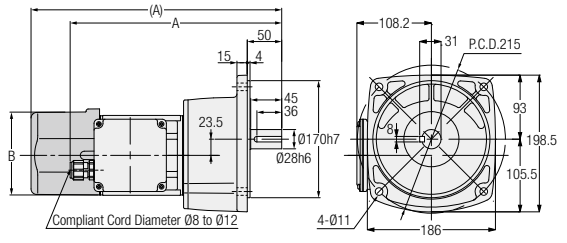

<Figure 3>

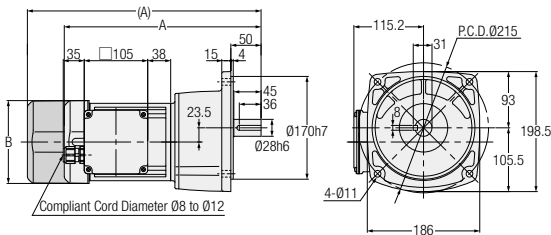

<Figure 4>

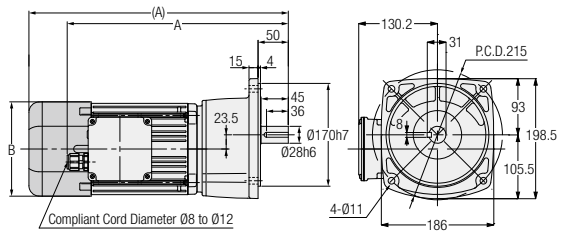

Number of Phases	Power	Output Shaft: Stainless Steel	Output Shaft: Carbon Steel	Reduction Ratio	Figure Number	Brake	Approx. Weight (kg)	A	B
3-Phase	0.1 kW	G3F28S***-WM01T◇◇EN	G3F28N***-WM01T◇◇EN	300, 375, 450	1	No	10.5	348.5	Ø115
		G3F28S***-WM01T◇◇EV◆	G3F28N***-WM01T◇◇EV◆			Yes	12	376	Ø115
	0.2 kW	G3F28S***-WM02T◇◇EN	G3F28N***-WM02T◇◇EN	100, 120, 160, 200	2	No	10	307.5	Ø115
		G3F28S***-WM02T◇◇EV◆	G3F28N***-WM02T◇◇EV◆			Yes	11.5	364	□126
	0.4 kW	G3F28S***-WM04T◇◇EN	G3F28N***-WM04T◇◇EN	30, 40, 50, 60, 80, 100	3	No	12	325.5	□137
		G3F28S***-WM04T◇◇EV◆	G3F28N***-WM04T◇◇EV◆			Yes	13.5	386.5	□137
0.75 kW	G3F28S***-WD08T◇◇EN	G3F28N***-WD08T◇◇EN	5, 10, 15, 20, 25	4	No	19	368	□156	
	G3F28S***-WD08T◇◇EV◆	G3F28N***-WD08T◇◇EV◆			Yes	21.5	429	□156	

Note: A reduction ratio will be indicated as *** in the nomenclature. In addition, a supply voltage/certification code will be indicated as ◇◇, and a brake specification will be indicated as ◆.

Note: Please refer to page 120 for the performance table.

Note: For the dimensions of the output shaft key, refer to page 869.

Note: The carbon steel output shaft is provided with a tap as a standard specification. Please refer to page 904 for information of the size.

G/G3 Type Parallel Shaft

H/H2 Type Right Angle Shaft

F Type Right Angle Hollow Bore/Right Angle Shaft

F2/F3 Type Concentric Right Angle Hollow Bore/Concentric Right Angle Shaft

Technical Documentation

G3 Type Parallel Shaft Shaft Diameter **32** **Flange Mounting**

The values in parenthesis are those for gearmotors with a brake.

<Figure 1>

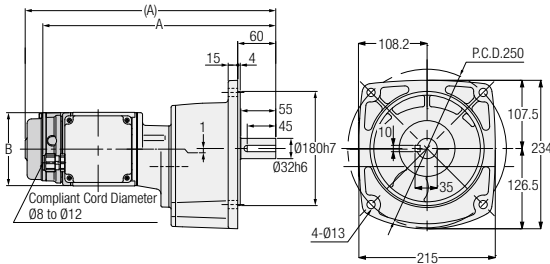

<Figure 2>

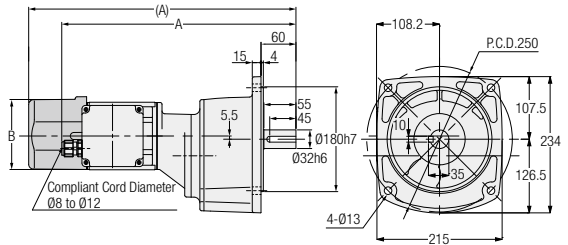

<Figure 3>

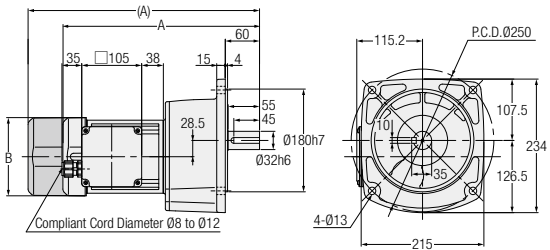

<Figure 4>

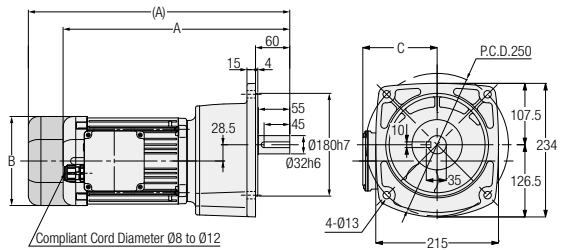

Number of Phases	Power	Output Shaft: Stainless Steel	Output Shaft: Carbon Steel	Reduction Ratio	Figure Number	Brake	Approx. Weight (kg)	A	B	C
3-Phase	0.1 kW	G3F32S***-WM01T◇◇EN	G3F32N***-WM01T◇◇EN	600, 750, 900, 1200	1	No	13.5	367.5	∅115	-
		G3F32S***-WM01T◇◇EV◆	G3F32N***-WM01T◇◇EV◆			Yes	15	395	∅115	-
	0.2 kW	G3F32S***-WM02T◇◇EN	G3F32N***-WM02T◇◇EN	300, 375, 450	2	No	14	402.5	∅115	-
		G3F32S***-WM02T◇◇EV◆	G3F32N***-WM02T◇◇EV◆			Yes	15.5	459	□126	-
	0.4 kW	G3F32S***-WM04T◇◇EN	G3F32N***-WM04T◇◇EN	100, 120, 160, 200	3	No	15	344.5	□137	-
		G3F32S***-WM04T◇◇EV◆	G3F32N***-WM04T◇◇EV◆			Yes	16.5	405.5	□137	-
0.75 kW	G3F32S***-WD08T◇◇EN	G3F32N***-WD08T◇◇EN	30, 40, 50, 60, 80, 100	4	No	22.5	397	□156	130.2	
	G3F32S***-WD08T◇◇EV◆	G3F32N***-WD08T◇◇EV◆			Yes	25	458	□156	130.2	
1.5 kW	G3F32S***-WD15T◇◇EN	G3F32N***-WD15T◇◇EN	5, 10, 15, 20, 25	4	No	28.5	449	□178	137.2	

Note: A reduction ratio will be indicated as *** in the nomenclature. In addition, a supply voltage/certification code will be indicated as ◇◇, and a brake specification will be indicated as ◆.

Note: There are no gearmotors with motor power of 1.5 kW that have a brake.

Note: Please refer to page 120 for the performance table.

Note: For the dimensions of the output shaft key, refer to page 869.

Note: The carbon steel output shaft is provided with a tap as a standard specification. Please refer to page 904 for information of the size.

G3 Type Parallel Shaft Shaft Diameter **40** Flange Mounting

The values in parenthesis are those for gearmotors with a brake.

<Figure 1>

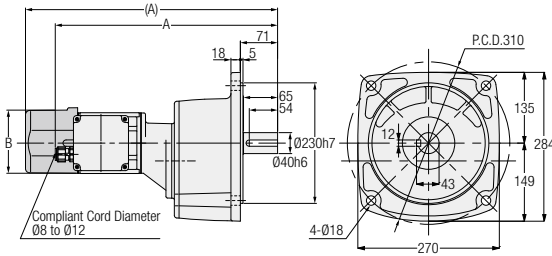

<Figure 2>

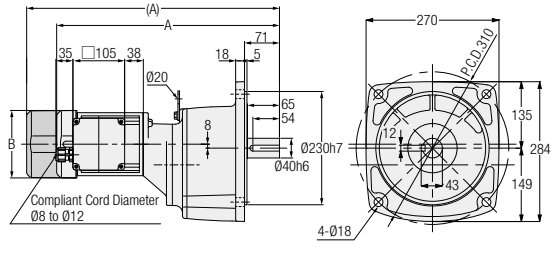

<Figure 3>

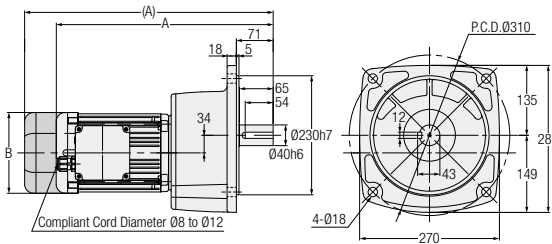

<Figure 4>

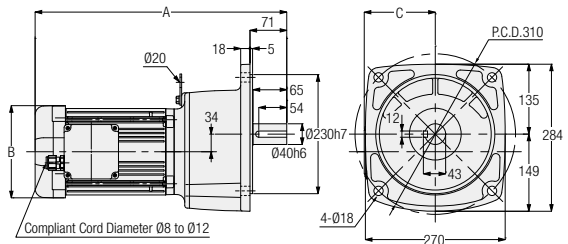

Number of Phases	Power	Output Shaft: Stainless Steel	Output Shaft: Carbon Steel	Reduction Ratio	Figure Number	Brake	Approx. Weight (kg)	A	B	C
3-Phase	0.2 kW	G3F40S***-WM02T◇◇EN	G3F40N***-WM02T◇◇EN	600, 750, 900, 1200	1	No	21.5	424.5	Ø115	-
		G3F40S***-WM02T◇◇EV◆	G3F40N***-WM02T◇◇EV◆			Yes	23	481	□126	-
	0.4 kW	G3F40S***-WM04T◇◇EN	G3F40N***-WM04T◇◇EN	300, 375, 450	2	No	24.5	452.5	□137	-
		G3F40S***-WM04T◇◇EV◆	G3F40N***-WM04T◇◇EV◆			Yes	26	513.5	□137	-
	0.75 kW	G3F40S***-WD08T◇◇EN	G3F40N***-WD08T◇◇EN	100, 120, 160, 200	3	No	30	419	□156	-
		G3F40S***-WD08T◇◇EV◆	G3F40N***-WD08T◇◇EV◆			Yes	32.5	480	□156	-
1.5 kW	G3F40S***-WD15T◇◇EN	G3F40N***-WD15T◇◇EN	30, 40, 50, 60, 80, 100	4	No	36.5	486	□178	137.2	
2.2 kW	G3F40S***-WD22T◇◇EN	G3F40N***-WD22T◇◇EN	5, 10, 15, 20, 25	4	No	43	503.5	□192	147.2	

Note: A reduction ratio will be indicated as *** in the nomenclature. In addition, a supply voltage/certification code will be indicated as ◇◇, and a brake specification will be indicated as ◆.

Note: There are no gearmotors with motor power of 1.5 kW and 2.2 kW that have a brake.

Note: Please refer to page 120 for the performance table.

Note: For the dimensions of the output shaft key, refer to page 869.

Note: The carbon steel output shaft is provided with a tap as a standard specification. Please refer to page 904 for information of the size.

G/G3 Type Parallel Shaft

H/H2 Type Right Angle Shaft

F Type Right Angle Hollow Bore/Right Angle Shaft

F2/F3 Type Concentric Right Angle Hollow Bore/Concentric Right Angle Shaft

Technical Documentation

G3 Type Parallel Shaft **Shaft Diameter 50** **Flange Mounting**

The values in parenthesis are those for gearmotors with a brake.

<Figure 1>

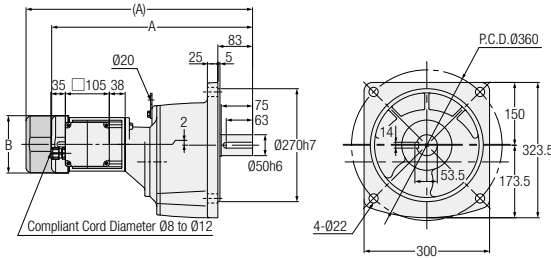

<Figure 2>

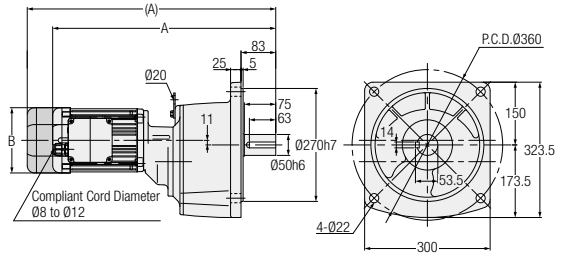

<Figure 3>

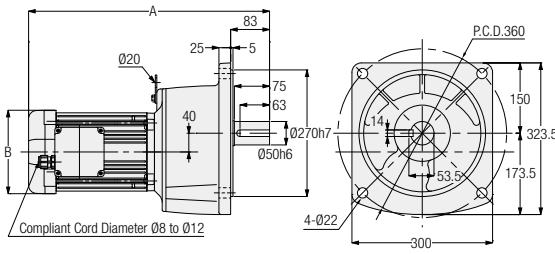

Number of Phases	Power	Output Shaft: Stainless Steel	Output Shaft: Carbon Steel	Reduction Ratio	Figure Number	Brake	Approx. Weight (kg)	A	B
3-Phase	0.4 kW	G3F50S***-WM04T◇◇EN	G3F50N***-WM04T◇◇EN	600, 750, 900, 1200	1	No	57.5	480.5	□137
		G3F50S***-WM04T◇◇EV◆	G3F50N***-WM04T◇◇EV◆			Yes	59	541.5	□137
	0.75 kW	G3F50S***-WD08T◇◇EN	G3F50N***-WD08T◇◇EN	300, 375, 450	2	No	65	533	□156
		G3F50S***-WD08T◇◇EV◆	G3F50N***-WD08T◇◇EV◆			Yes	67.5	594	□156
1.5 kW	G3F50S***-WD15T◇◇EN	G3F50N***-WD15T◇◇EN	100, 120, 160, 200	3	No	69.5	514	□178	
2.2 kW	G3F50S***-WD22T◇◇EN	G3F50N***-WD22T◇◇EN	30, 40, 50, 60, 80, 100	3	No	76.5	547.5	□192	

Note: A reduction ratio will be indicated as *** in the nomenclature. In addition, a supply voltage/certification code will be indicated as ◇◇, and a brake specification will be indicated as ◆.

Note: There are no gearmotors with motor power of 1.5 kW and 2.2 kW that have a brake.

Note: Please refer to page 121 for the performance table.

Note: For the dimensions of the output shaft key, refer to page 869.

Note: The carbon steel output shaft is provided with a tap as a standard specification. Please refer to page 904 for information of the size.

G3 Type Parallel Shaft

Shaft Diameter **18**

Small Flange Mounting

The values in parenthesis are those for gearmotors with a brake.

<Figure 1>

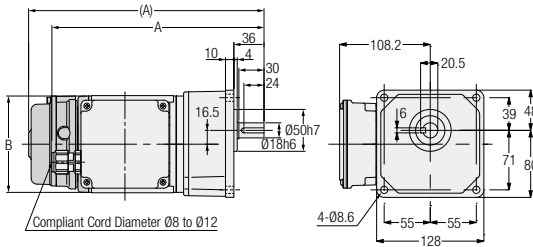

<Figure 2>

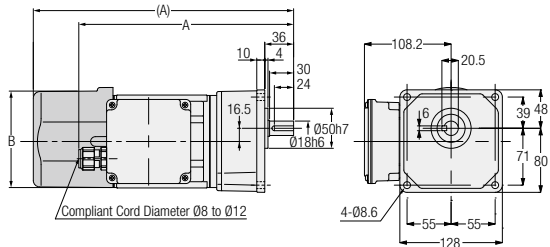

Number of Phases	Power	Output Shaft: Stainless Steel	Output Shaft: Carbon Steel	Reduction Ratio	Figure Number	Brake	Approx. Weight (kg)	A	B	
3-Phase	0.1 kW	G3K18S***-WM01T◇◇EN	G3K18N***-WM01T◇◇EN	5, 10, 15, 20, 25, 30, 40, 50	1	No	6.5	253.5	Ø115	
		G3K18S***-WM01T◇◇EV◆	G3K18N***-WM01T◇◇EV◆			Yes	8	281	Ø115	
	0.2 kW	G3K18S***-WM02T◇◇EN	G3K18N***-WM02T◇◇EN	5, 10, 15, 20, 25		2	No	7	268.5	Ø115
		G3K18S***-WM02T◇◇EV◆	G3K18N***-WM02T◇◇EV◆				Yes	8.5	325	□126

Note: A reduction ratio will be indicated as *** in the nomenclature. In addition, a supply voltage/certification code will be indicated as ◇◇, and a brake specification will be indicated as ◆.

Note: Please refer to page 120 for the performance table.

Note: For the dimensions of the output shaft key, refer to page 869.

Note: The carbon steel output shaft is provided with a tap as a standard specification. Please refer to page 904 for information of the size.

G/G3 Type Parallel Shaft

H/H2 Type Right Angle Shaft

F Type Right Angle Hollow Bore/Right Angle Shaft

F2/F3 Type Concentric Right Angle Hollow Bore/Concentric Right Angle Shaft

Technical Documentation

G3 Type Parallel Shaft

Shaft Diameter **22**

Small Flange Mounting

The values in parenthesis are those for gearmotors with a brake.

<Figure 1>

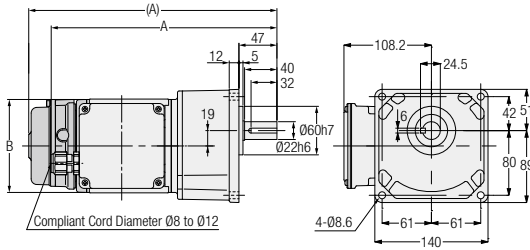

<Figure 2>

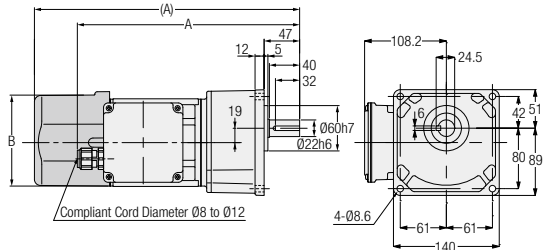

<Figure 3>

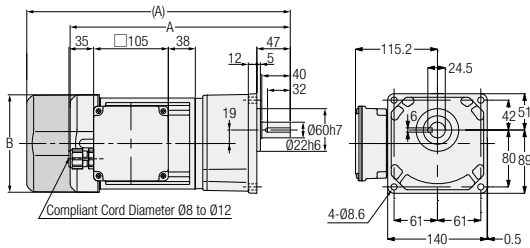

Number of Phases	Power	Output Shaft: Stainless Steel	Output Shaft: Carbon Steel	Reduction Ratio	Figure Number	Brake	Approx. Weight (kg)	A	B
3-Phase	0.1 kW	G3K22S***-WM01T◇◇EN	G3K22N***-WM01T◇◇EN	60, 80, 100, 120, 160, 200	1	No	7.5	279.5	Ø115
		G3K22S***-WM01T◇◇EV◆	G3K22N***-WM01T◇◇EV◆			Yes	9	307	Ø115
	0.2 kW	G3K22S***-WM02T◇◇EN	G3K22N***-WM02T◇◇EN	30, 40, 50, 60, 80, 100	2	No	8	294.5	Ø115
		G3K22S***-WM02T◇◇EV◆	G3K22N***-WM02T◇◇EV◆			Yes	9.5	351	□126
0.4 kW	G3K22S***-WM04T◇◇EN	G3K22N***-WM04T◇◇EN	5, 10, 15, 20, 25	3	No	10	309.5	□137	
	G3K22S***-WM04T◇◇EV◆	G3K22N***-WM04T◇◇EV◆			Yes	11.5	370.5	□137	

Note: A reduction ratio will be indicated as *** in the nomenclature. In addition, a supply voltage/certification code will be indicated as ◇◇, and a brake specification will be indicated as ◆.

Note: Please refer to page 120 for the performance table.

Note: For the dimensions of the output shaft key, refer to page 869.

Note: The carbon steel output shaft is provided with a tap as a standard specification. Please refer to page 904 for information of the size.

G3 Type Parallel Shaft Shaft Diameter **28** Small Flange Mounting

The values in parenthesis are those for gearmotors with a brake.

<Figure 1>

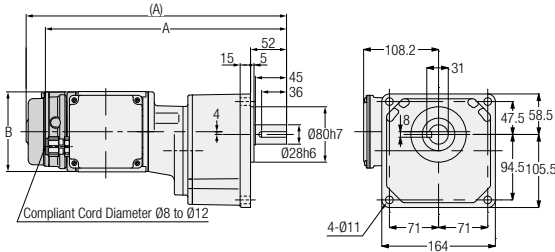

<Figure 2>

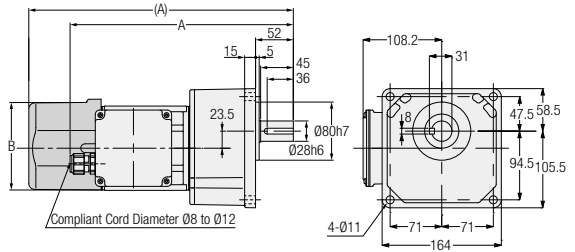

<Figure 3>

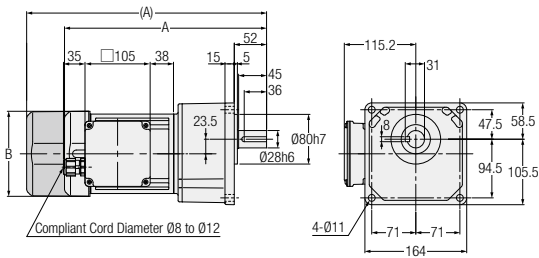

<Figure 4>

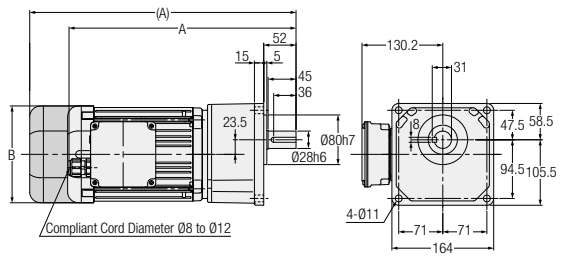

Number of Phases	Power	Output Shaft: Stainless Steel	Output Shaft: Carbon Steel	Reduction Ratio	Figure Number	Brake	Approx. Weight (kg)	A	B
3-Phase	0.1 kW	G3K28S***-WM01T◇◇EN	G3K28N***-WM01T◇◇EN	300, 375, 450	1	No	10.5	348.5	Ø115
		G3K28S***-WM01T◇◇EV◆	G3K28N***-WM01T◇◇EV◆			Yes	12	376	Ø115
	0.2 kW	G3K28S***-WM02T◇◇EN	G3K28N***-WM02T◇◇EN	100, 120, 160, 200	2	No	10	307.5	Ø115
		G3K28S***-WM02T◇◇EV◆	G3K28N***-WM02T◇◇EV◆			Yes	11.5	364	□126
	0.4 kW	G3K28S***-WM04T◇◇EN	G3K28N***-WM04T◇◇EN	30, 40, 50, 60, 80, 100	3	No	12	325.5	□137
		G3K28S***-WM04T◇◇EV◆	G3K28N***-WM04T◇◇EV◆			Yes	13.5	386.5	□137
0.75 kW	G3K28S***-WD08T◇◇EN	G3K28N***-WD08T◇◇EN	5, 10, 15, 20, 25	4	No	19	368	□156	
	G3K28S***-WD08T◇◇EV◆	G3K28N***-WD08T◇◇EV◆			Yes	21.5	429	□156	

Note: A reduction ratio will be indicated as *** in the nomenclature. In addition, a supply voltage/certification code will be indicated as ◇◇, and a brake specification will be indicated as ◆.

Note: Please refer to page 120 for the performance table.

Note: For the dimensions of the output shaft key, refer to page 869.

Note: The carbon steel output shaft is provided with a tap as a standard specification. Please refer to page 904 for information of the size.

G/G3 Type Parallel Shaft

H/H2 Type Right Angle Shaft

F Type Right Angle Hollow Bore/Right Angle Shaft

F2/F3 Type Concentric Right-Angle Hollow Bore/Concentric Right Angle Shaft

Technical Documentation

G3 Type Parallel Shaft

Shaft Diameter **32**

Small Flange Mounting

The values in parenthesis are those for gearmotors with a brake.

<Figure 1>

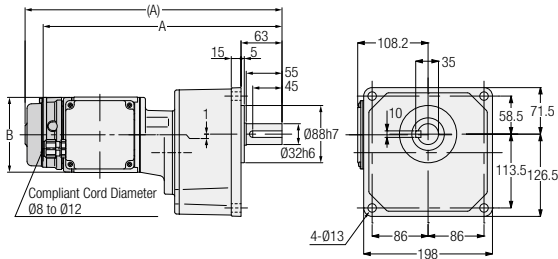

<Figure 2>

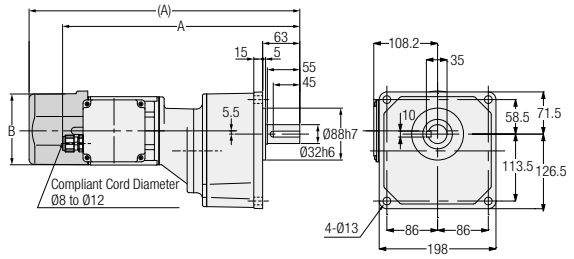

<Figure 3>

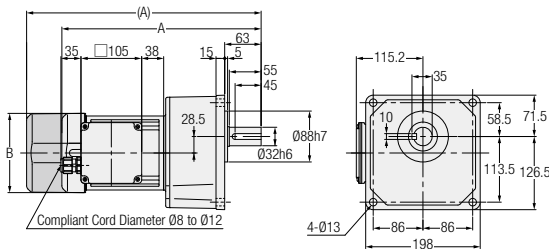

<Figure 4>

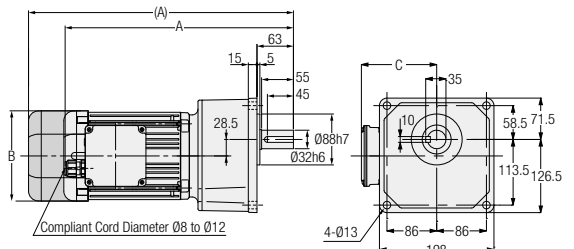

Number of Phases	Power	Output Shaft: Stainless Steel	Output Shaft: Carbon Steel	Reduction Ratio	Figure Number	Brake	Approx. Weight (kg)	A	B	C
3-Phase	0.1 kW	G3K32S***-WM01T◇◇EN	G3K32N***-WM01T◇◇EN	600, 750, 900, 1200	1	No	13.5	367.5	Ø115	-
		G3K32S***-WM01T◇◇EV◆	G3K32N***-WM01T◇◇EV◆			Yes	15	395	Ø115	-
	0.2 kW	G3K32S***-WM02T◇◇EN	G3K32N***-WM02T◇◇EN	300, 375, 450	2	No	14	402.5	Ø115	-
		G3K32S***-WM02T◇◇EV◆	G3K32N***-WM02T◇◇EV◆			Yes	15.5	459	□126	-
	0.4 kW	G3K32S***-WM04T◇◇EN	G3K32N***-WM04T◇◇EN	100, 120, 160, 200	3	No	15	344.5	□137	-
		G3K32S***-WM04T◇◇EV◆	G3K32N***-WM04T◇◇EV◆			Yes	16.5	405.5	□137	-
0.75 kW	G3K32S***-WD08T◇◇EN	G3K32N***-WD08T◇◇EN	30, 40, 50, 60, 80, 100	4	No	22.5	397	□156	130.2	
	G3K32S***-WD08T◇◇EV◆	G3K32N***-WD08T◇◇EV◆			Yes	25	458	□156	130.2	
1.5 kW	G3K32S***-WD15T◇◇EN	G3K32N***-WD15T◇◇EN	5, 10, 15, 20, 25	4	No	28.5	449	□178	137.2	

Note: A reduction ratio will be indicated as *** in the nomenclature. In addition, a supply voltage/certification code will be indicated as ◇◇, and a brake specification will be indicated as ◆.

Note: There are no gearmotors with motor power of 1.5 kW that have a brake.

Note: Please refer to page 120 for the performance table.

Note: For the dimensions of the output shaft key, refer to page 869.

Note: The carbon steel output shaft is provided with a tap as a standard specification. Please refer to page 904 for information of the size.

MEMO

<p>Technical Documentation</p>	<p>F2/F3 Type Concentric Right-Angle Hollow Bore/ Concentric Right Angle Shaft</p>	<p>F Type Right Angle Hollow Bore/ Right Angle Shaft</p>	<p>H/H2 Type Right Angle Shaft</p>	<p>G/G3 Type Parallel Shaft</p>
--------------------------------	--	--	--	-------------------------------------

3. Gearmotors with Clutch/Brake

3-1. Motor Characteristics Table

G3 Type 3-Phase Standard Voltage

Series	Power	Voltage (V)	Frequency (Hz)	Rated Current (A)	Rated Speed (r/min)
MID	0.1 kW	200/200/220	50/60/60	0.61/0.54/0.54	1410/1690/1710
	0.2 kW IE2	200/200/220	50/60/60	1.1/1.0/1.0	1400/1680/1700
	0.4 kW IE2	200/200/220	50/60/60	2.1/1.8/1.8	1400/1680/1700
	0.75 kW IE3	200/200/220	50/60/60	3.2/3.0/2.9	1440/1720/1740

G3 Type 3-Phase High Voltage (400 V Class)

Series	Power	Voltage (V)	Frequency (Hz)	Rated Current (A)	Rated Speed (r/min)
MID	0.1 kW	380/400/400/440	50/50/60/60	0.31/0.31/0.28/0.28	1400/1410/1690/1720
	0.2 kW IE2	380/400/400/440	50/50/60/60	0.56/0.56/0.5/0.5	1390/1400/1680/1710
	0.4 kW IE2	380/400/400/440	50/50/60/60	1.0/1.0/0.9/0.9	1390/1400/1680/1710
	0.75 kW IE3	380/400/400/440	50/50/60/60	1.65/1.6/1.5/1.4	1430/1440/1730/1740

G/G3 Type
Parallel Shaft

H/H2 Type
Right Angle Shaft

F Type
Right Angle Hollow Bore/
Right Angle Shaft

F2/F3 Type
Concentric Right Angle Hollow Bore/
Concentric Right Angle Shaft

Technical Documentation

3-2. Performance Table

[Notes]

- The output shaft speed is the value relative to the synchronous speed of the motor and the reduction ratio.
-  in the performance table indicates that the shaft rotates clockwise when viewed from the output shaft side when the connection is made as shown on page 503 (CW). (Refer to the figure on the right)
- Allowable output shaft O.H.L. is the value at the middle of the output shaft.
- The "*" mark indicates a limited torque type. Please make sure to check the allowable output shaft torque in the performance table.
- Please avoid using gearmotors with clutch/brake in vertical operation (lifting). There is a danger of falling during a power outage.

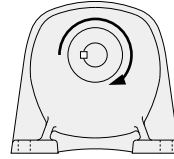

Motor Power	Frame Size	Reduction Ratio	Actual Reduction Ratio	Output Shaft Speed		Allowable Output Shaft Torque		Allowable Output Shaft O.H.L.	Drawings				
				r/min		N·m		N	Foot Mount	Flange Mount	Small Flange Mount		
				50 Hz	60 Hz	50 Hz	60 Hz						
3-Phase 0.1 kW	18	1/5	33/164	300	360	3	2.5	770	P.145	P.147	P.150		
		1/10	77/779	150	180	6.1	5	1140					
		1/15	119/1804	100	120	9.1	7.5	1270					
		1/20	49/984	75	90	12	9.8	1530					
		1/25	28/697	60	72	15	12.7	1650					
		1/30	35/1066	50	60	19	14.7	1780					
		1/40	35/1404	37.5	45	24	19.6	1910					
	22	1/50	7/351	30	36	29	24.5	2040	P.145	P.148	P.150		
		1/60	11/684	25	30	35	29.4	2800					
		1/80	21/1634	18.8	22.5	47	39.2	3180					
		1/100	7/684	15	18	59	49	3180					
		1/120	147/17974	12.5	15	71	58.8	3180					
		1/160	21/3268	9.4	11.2	94	78.4	3180					
		1/200	21/4085	7.5	9	117	98	3180					
3-Phase 0.2 kW	18	1/5	33/164	300	360	6.1	5	770	P.145	P.147	P.150		
		1/10	77/779	150	180	11.8	9.8	1140					
		1/15	119/1804	100	120	18.6	14.7	1270					
		1/20	49/984	75	90	24.5	20.6	1450					
		1/25	28/697	60	72	30.4	25.5	1550					
	22	1/30	7/216	50	60	36.3	30.4	2280	P.145	P.148	P.150		
		1/40	91/3600	37.5	45	47	39.2	2410					
		1/50	11/540	30	36	58.8	49	2540					
		1/60	637/39600	25	30	70.6	58.8	2800					
		1/80	91/7200	18.8	22.5	94.1	78.4	3000					
		* 1/100	11/1080	15	18	97	80.4	3180					
		1/100	13/1353	15	18	117	98	3690					
	28	1/120	91/11000	12.5	15	140	117	4320	P.146	P.148	P.151		
		1/160	1/165	9.4	11.2	187	156	4450					
1/200		7/1375	7.5	9	234	195	4450						
1/5		7/34	300	360	12	10	1140	P.145				P.148	P.150
1/10	7/68	150	180	25	21	1530							
1/15	49/748	100	120	36	30	1780							
1/20	7/136	75	90	48	40	1910							
1/25	7/170	60	72	61	50	2050							
28	1/30	1/30	50	60	73	61	3310		P.146	P.148	P.151		
	1/40	221/8610	37.5	45	94	78	3690						
	1/50	187/9030	30	36	117	98	4080						
	1/60	169/9840	25	30	140	117	4450						
	1/80	65/5166	18.8	22.5	187	156	4450						
	* 1/100	55/5418	15	18	193	161	4450						
	1/100	7/688	15	18	234	195	6370	P.146				P.149	P.151
1/120	77/9360	12.5	15	281	234	7640							
1/160	21/3328	9.4	11.2	374	313	7640							
1/200	189/38272	7.5	9	431	390	7640							

G/G3 Type
Parallel Shaft

H/H2 Type
Right Angle Shaft

F Type
Right Angle Hollow Bore/
Right Angle Shaft

F2/F3 Type
Concentric Right Angle Hollow Bore/
Concentric Right Angle Shaft

Technical Documentation

Motor Power	Frame Size	Reduction Ratio	Actual Reduction Ratio	Output Shaft Speed		Allowable Output Shaft Torque		Allowable Output Shaft O.H.L. N	Drawings			
				r/min		N-m			Foot Mount	Flange Mount	Small Flange Mount	
				50 Hz	60 Hz	50 Hz	60 Hz					
3-Phase 0.75 kW	28	1/5	91/459	300	360	23	19	1650	P.146	P.148	P.151	
		1/10	1/10	150	180	45	38					2280
		1/15	91/1360	100	120	68	57					2800
		1/20	5/102	75	90	91	75					3050
		1/25	7/170	60	72	114	94					3180
	32	1/30	3/92	50	60	136	114	5220	P.146	P.149	P.151	
		1/40	13/516	37.5	45	175	146	5470				
		1/50	11/540	30	36	220	183	5780				
		1/60	13/774	25	30	264	220	6080				
		1/80	13/1032	18.8	22.5	351	293	6180				
		* 1/100	11/1080	15	18	362	302	6770				
	40	1/100	91/9000	15	18	439	366	9170	P.147	P.149	-	
		1/120	77/9400	12.5	15	527	439	9170				
		1/160	9/1400	9.4	11.2	703	585	9170				
		1/200	9/1750	7.5	9	764	732	9170				

Note 1: Please be sure to read the notes on page 143.

3-3. Drawings

G3 Type Parallel Shaft Shaft Diameter **18** Foot Mounting

<Figure 1>

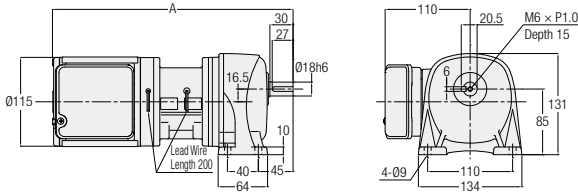

Number of Phases	Power	Part Number	Reduction Ratio	Figure Number	Approx. Weight (kg)	A
3-Phase	0.1 kW	G3L18N***-EM01T◇JTN	5, 10, 15, 20, 25, 30, 40, 50	1	7	311.5
	0.2 kW	G3L18N***-EM02T◇JTN	5, 10, 15, 20, 25	1	9	326.5

Note: A reduction ratio will be indicated as *** in the nomenclature. In addition, a supply voltage code will be indicated as ◇.
Note: Please refer to page 143 for the performance table.

G3 Type Parallel Shaft Shaft Diameter **22** Foot Mounting

<Figure 2>

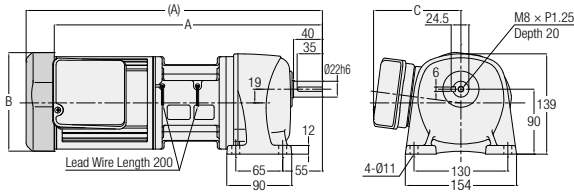

Note: The value in parentheses is the value of a gearmotor with a motor power of 0.4 kW.

Number of Phases	Power	Part Number	Reduction Ratio	Figure Number	Approx. Weight (kg)	A	B	C
3-Phase	0.1 kW	G3L22N***-EM01T◇JTN	60, 80, 100, 120, 160, 200	2	8.5	337.5	∅115	110
	0.2 kW	G3L22N***-EM02T◇JTN	30, 40, 50, 60, 80, 100	2	10	352.5	∅115	110
	0.4 kW	G3L22N***-EM04T◇JTN	5, 10, 15, 20, 25	2	12.5	410.5	□137	121

Note: A reduction ratio will be indicated as *** in the nomenclature. In addition, a supply voltage code will be indicated as ◇.
Note: Please refer to page 143 for the performance table.

G/G3 Type
Parallel Shaft

H/H2 Type
Right Angle Shaft

F Type
Right Angle Hollow Bore/
Right Angle Shaft

F2/F3 Type
Concentric Right Angle Hollow Bore/
Concentric Right Angle Shaft

Technical Documentation

G3 Type Parallel Shaft **Shaft Diameter 28** **Foot Mounting**

<Figure 1>

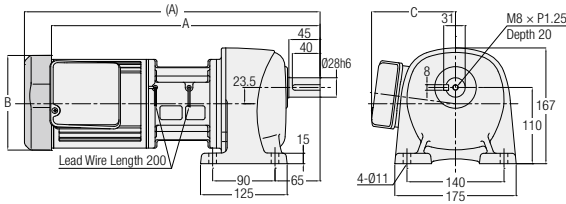

Note: The value in parentheses is the value of a gearmotor with a motor power of 0.4 kW or 0.75 kW.

Number of Phases	Power	Part Number	Reduction Ratio	Figure Number	Approx. Weight (kg)	A	B	C
3-Phase	0.2 kW	G3L28N***-EM02T◇JTN	100, 120, 160, 200	1	12	365.5	Ø115	110
	0.4 kW	G3L28N***-EM04T◇JTN	30, 40, 50, 60, 80, 100	1	14.5	426.5	□137	121
	0.75 kW	G3L28N***-ED08T◇JTN	5, 10, 15, 20, 25	1	22	468.5	□156	136

Note: A reduction ratio will be indicated as *** in the nomenclature. In addition, a supply voltage code will be indicated as ◇.
 Note: Please refer to page 143 for the performance table.

G3 Type Parallel Shaft **Shaft Diameter 32** **Foot Mounting**

<Figure 2>

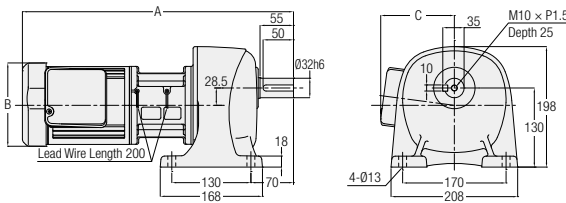

Number of Phases	Power	Part Number	Reduction Ratio	Figure Number	Approx. Weight (kg)	A	B	C
3-Phase	0.4 kW	G3L32N***-EM04T◇JTN	100, 120, 160, 200	2	17.5	445.5	□138	121
	0.75 kW	G3L32N***-ED08T◇JTN	30, 40, 50, 60, 80, 100	2	25.5	497.5	□156	136

Note: A reduction ratio will be indicated as *** in the nomenclature. In addition, a supply voltage code will be indicated as ◇.
 Note: Please refer to page 143 for the performance table.

G3 Type Parallel Shaft Shaft Diameter **40** **Foot Mounting**

<Figure 1>

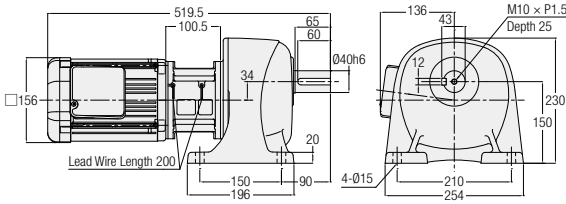

Number of Phases	Power	Part Number	Reduction Ratio	Figure Number	Approx. Weight (kg)
3-Phase	0.75 kW	G3L40N***-ED08T◇JTN	100, 120, 160, 200	1	32

Note: A reduction ratio will be indicated as *** in the nomenclature. In addition, a supply voltage code will be indicated as ◇.
 Note: Please refer to page 144 for the performance table.

G3 Type Parallel Shaft Shaft Diameter **18** **Flange Mounting**

<Figure 2>

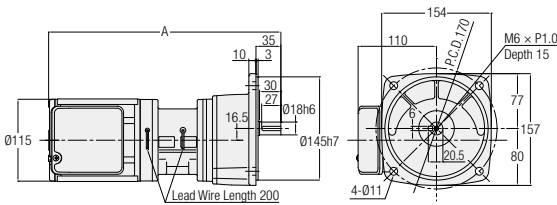

Number of Phases	Power	Part Number	Reduction Ratio	Figure Number	Approx. Weight (kg)	A
3-Phase	0.1 kW	G3F18N***-EM01T◇JTN	5, 10, 15, 20, 25, 30, 40, 50	2	7.5	311.5
	0.2 kW	G3F18N***-EM02T◇JTN	5, 10, 15, 20, 25	2	9.5	326.5

Note: A reduction ratio will be indicated as *** in the nomenclature. In addition, a supply voltage code will be indicated as ◇.
 Note: Please refer to page 143 for the performance table.

G/G3 Type Parallel Shaft

H/H2 Type Right Angle Shaft

F Type Right Angle Hollow Bore/ Right Angle Shaft

F2/F3 Type Concentric Right Angle Hollow Bore/ Concentric Right Angle Shaft

Technical Documentation

G3 Type Parallel Shaft Shaft Diameter **22** **Flange Mounting**

<Figure 1>

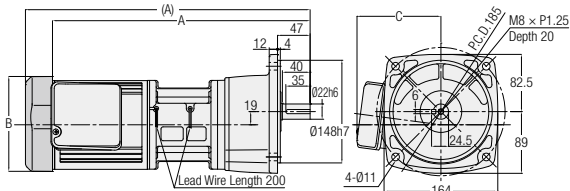

Note: The value in parentheses is the value of a gearmotor with a motor power of 0.4 kW.

Number of Phases	Power	Part Number	Reduction Ratio	Figure Number	Approx. Weight (kg)	A	B	C
3-Phase	0.1 kW	G3F22N***-EM01T◇JTN	60, 80, 100, 120, 160, 200	1	9	337.5	∅115	110
	0.2 kW	G3F22N***-EM02T◇JTN	30, 40, 50, 60, 80, 100	1	10.5	352.5	∅115	110
	0.4 kW	G3F22N***-EM04T◇JTN	5, 10, 15, 20, 25	1	13	410.5	□137	121

Note: A reduction ratio will be indicated as *** in the nomenclature. In addition, a supply voltage code will be indicated as ◇.

Note: Please refer to page 143 for the performance table.

G3 Type Parallel Shaft Shaft Diameter **28** **Flange Mounting**

<Figure 2>

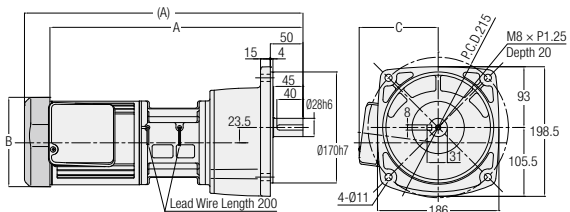

Note: The value in parentheses is the value of a gearmotor with a motor power of 0.4 kW or 0.75 kW

Number of Phases	Power	Part Number	Reduction Ratio	Figure Number	Approx. Weight (kg)	A	B	C
3-Phase	0.2 kW	G3F28N***-EM02T◇JTN	100, 120, 160, 200	2	12.5	365.5	∅115	110
	0.4 kW	G3F28N***-EM04T◇JTN	30, 40, 50, 60, 80, 100	2	15	426.5	□137	121
	0.75 kW	G3F28N***-ED08T◇JTN	5, 10, 15, 20, 25	2	22.5	468.5	□156	136

Note: A reduction ratio will be indicated as *** in the nomenclature. In addition, a supply voltage code will be indicated as ◇.

Note: Please refer to page 143 for the performance table.

G3 Type Parallel Shaft Shaft Diameter **32** Flange Mounting

<Figure 1>

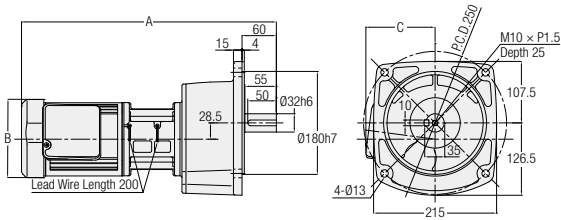

Number of Phases	Power	Part Number	Reduction Ratio	Figure Number	Approx. Weight (kg)	A	B	C
3-Phase	0.4 kW	G3F32N***-EM04T◇JTN	100, 120, 160, 200	1	18	445.5	□137	121
	0.75 kW	G3F32N***-ED08T◇JTN	30, 40, 50, 60, 80, 100	1	26	497.5	□156	136

Note: A reduction ratio will be indicated as *** in the nomenclature. In addition, a supply voltage code will be indicated as ◇.
 Note: Please refer to page 143 for the performance table.

G3 Type Parallel Shaft Shaft Diameter **40** Flange Mounting

<Figure 2>

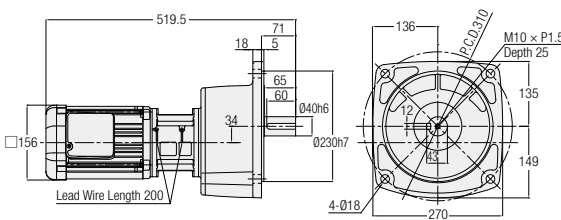

Number of Phases	Power	Part Number	Reduction Ratio	Figure Number	Approx. Weight (kg)
3-Phase	0.75 kW	G3F40N***-ED08T◇JTN	100, 120, 160, 200	2	26

Note: A reduction ratio will be indicated as *** in the nomenclature. In addition, a supply voltage code will be indicated as ◇.
 Note: Please refer to page 144 for the performance table.

G/G3 Type Parallel Shaft

H/H2 Type Right Angle Shaft

F Type Right Angle Hollow Bore/ Right Angle Shaft

F2/F3 Type Concentric Right Angle Hollow Bore/ Concentric Right Angle Shaft

Technical Documentation

G3 Type Parallel Shaft Shaft Diameter **18** **Small Flange Mounting**

<Figure 1>

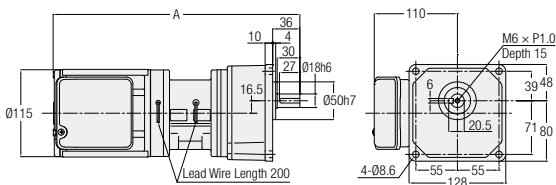

Number of Phases	Power	Part Number	Reduction Ratio	Figure Number	Approx. Weight (kg)	A
3-Phase	0.1 kW	G3K18N***-EM01T◇JTN	5, 10, 15, 20, 25, 30, 40, 50	1	7.5	311.5
	0.2 kW	G3K18N***-EM02T◇JTN	5, 10, 15, 20, 25	1	9.5	326.5

Note: A reduction ratio will be indicated as *** in the nomenclature. In addition, a supply voltage code will be indicated as ◇.
 Note: Please refer to page 143 for the performance table.

G3 Type Parallel Shaft Shaft Diameter **22** **Small Flange Mounting**

<Figure 2>

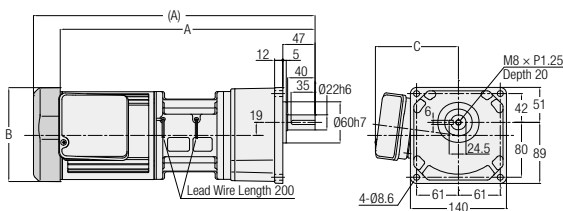

Note: The value in parentheses is the value of a gearmotor with a motor power of 0.4 kW.

Number of Phases	Power	Part Number	Reduction Ratio	Figure Number	Approx. Weight (kg)	A	B	C
3-Phase	0.1 kW	G3K22N***-EM01T◇JTN	60, 80, 100, 120, 160, 200	2	9	337.5	Ø115	110
	0.2 kW	G3K22N***-EM02T◇JTN	30, 40, 50, 60, 80, 100	2	10.5	352.5	Ø115	110
	0.4 kW	G3K22N***-EM04T◇JTN	5, 10, 15, 20, 25	2	13	410.5	□137	121

Note: A reduction ratio will be indicated as *** in the nomenclature. In addition, a supply voltage code will be indicated as ◇.
 Note: Please refer to page 143 for the performance table.

G3 Type Parallel Shaft Shaft Diameter **28** **Small Flange Mounting**

<Figure 1>

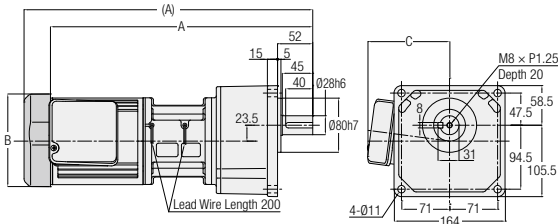

Note: The value in parentheses is the value of a gearmotor with a motor power of 0.4 kW or 0.75 kW.

Number of Phases	Power	Part Number	Reduction Ratio	Figure Number	Approx. Weight (kg)	A	B	C
3-Phase	0.2 kW	G3K28N***-EM02T◇JTN	100, 120, 160, 200	1	12.5	365.5	∅115	110
	0.4 kW	G3K28N***-EM04T◇JTN	30, 40, 50, 60, 80, 100	1	15	426.5	□137	121
	0.75 kW	G3K28N***-ED08T◇JTN	5, 10, 15, 20, 25	1	22.5	468.5	□156	136

Note: A reduction ratio will be indicated as *** in the nomenclature. In addition, a supply voltage code will be indicated as ◇.
 Note: Please refer to page 143 for the performance table.

G3 Type Parallel Shaft Shaft Diameter **32** **Small Flange Mounting**

<Figure 2>

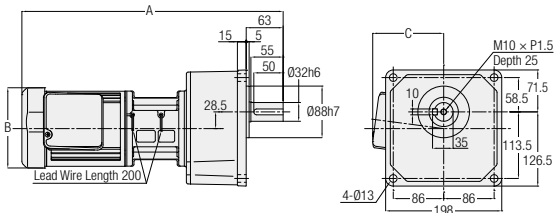

Number of Phases	Power	Part Number	Reduction Ratio	Figure Number	Approx. Weight (kg)	A	B	C
3-Phase	0.4 kW	G3K32N***-EM04T◇JTN	100, 120, 160, 200	2	18	445.5	□137	121
	0.75 kW	G3K32N***-ED08T◇JTN	30, 40, 50, 60, 80, 100	2	26	497.5	□156	136

Note: A reduction ratio will be indicated as *** in the nomenclature. In addition, a supply voltage code will be indicated as ◇.
 Note: Please refer to page 143 for the performance table.

G/G3 Type Parallel Shaft

H/H2 Type Right Angle Shaft

F Type Right Angle Hollow Bore/ Right Angle Shaft

F2/F3 Type Concentric Right Angle Hollow Bore/ Concentric Right Angle Shaft

Technical Documentation

4. Speed Control Gearmotors

4-1. Properties and Motor Characteristics Table

Properties

This gearmotor has a motor provided with a rate generator (AC generator) for speed detection and can control the speed freely in a wide range of 50 to 1400 r/min (50 Hz) or 50 to 1700 r/min (60 Hz) by means of a dedicated speed controller.

■ Properties

① Wide variable speed range

Our original circuit design enables the induction gearmotor to operate continuously from a low speed range of 50 r/min.

Power Source Frequency	Variable speed range
50 Hz	50 to 1400 r/min
60 Hz	50 to 1700 r/min

② Outstanding output characteristic

The induction motor ensures a high allowable load torque value in the low speed range and has a wide high-speed range characteristic as shown in the right figure.

③ Wide variety of types

Induction gearmotors are available in eight main types according to applications: two U types (100 V, 200 V) connectable by means of a lead wire with a connector and six plug-in P types (100 V, 200 V).

Note: Please refer to page 571 for detailed specifications.

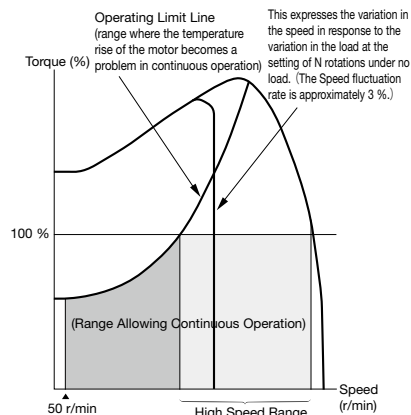

Note: The same speed can be obtained from a speed control gearmotor, regardless of the power supply frequency. For example, a speed set in the 50 Hz region remains unchanged also in the 60 Hz region, and the same speed can be obtained. (However, the maximum speed is within the range of 1400 r/min.)

Motor Characteristics Table

G Type 1-Phase (Speed Control Gearmotors)

Series	Power (W)	Voltage (V)	Frequency (Hz)	Frame Size	Max Current (A)	High Speed Range (r/min)	Capacitor (μF)	
MINI	15 W	100/100	50/60	12	0.6/0.6	500 to 1350/550 to 1650	6	
				22	0.6/0.6	500 to 1350/550 to 1650	6	
		200/200	50/60	12	0.3/0.3	600 to 1400/750 to 1700	1.5	
				22	0.3/0.3	600 to 1400/750 to 1700	1.5	
		25 W	100/100	50/60	12	0.6/0.6	750 to 1350/1000 to 1650	8
					15	0.7/0.7	550 to 1400/650 to 1650	8
	22				0.6/0.6	750 to 1350/1000 to 1650	8	
	200/200		50/60	28	0.7/0.7	550 to 1400/650 to 1650	8	
				12	0.4/0.4	850 to 1350/1000 to 1650	2	
				15	0.4/0.4	600 to 1350/800 to 1650	2	
	40 W	100/100	50/60	22	0.4/0.4	850 to 1350/1000 to 1650	2	
				28	0.4/0.4	600 to 1350/800 to 1650	2	
				15	0.9/0.9	800 to 1350/1050 to 1650	12	
		200/200	50/60	18	1.1/0.9	850 to 1400/1200 to 1700	12	
				28	0.9/0.9	800 to 1350/1050 to 1650	12	
				32	0.9/0.9	800 to 1350/1050 to 1650	12	
	60 W	100/100	50/60	15	0.5/0.5	900 to 1350/1300 to 1650	3	
				18	0.6/0.6	850 to 1400/1100 to 1700	3	
				28	0.5/0.5	900 to 1350/1300 to 1650	3	
				32	0.5/0.5	900 to 1350/1300 to 1650	3	
				15	1.0/1.7	700 to 1350/800 to 1650	20	
				18	1.3/1.3	500 to 1400/650 to 1650	20	
		200/200	50/60	28	1.0/1.7	700 to 1350/800 to 1650	20	
				32	1.0/1.7	700 to 1350/800 to 1650	20	
15				0.8/0.9	700 to 1350/800 to 1650	5		
18				0.8/0.9	750 to 1400/850 to 1650	5		
28				0.8/0.9	700 to 1350/800 to 1650	5		
32				0.8/0.9	700 to 1350/800 to 1650	5		
90 W	100/100	50/60	15	1.4/2.0	950 to 1300/1150 to 1600	26		
			18	1.4/2.0	950 to 1350/1100 to 1650	26		
			28	1.4/2.0	950 to 1300/1150 to 1600	26		
			32	1.4/2.0	950 to 1300/1150 to 1600	26		
			40	1.4/2.0	950 to 1350/1100 to 1650	26		
			15	0.9/1.0	1000 to 1350/1150 to 1600	6.5		
	200/200	50/60	18	1.0/1.1	900 to 1350/1100 to 1650	6.5		
			28	0.9/1.0	1000 to 1350/1150 to 1600	6.5		
			32	0.9/1.0	1000 to 1350/1150 to 1600	6.5		
			40	1.0/1.1	900 to 1350/1100 to 1650	6.5		

4-2. Graph for Speed Characteristics

Torque-Speed Characteristic Graph

<1-Phase 15 W>

■ 100 V

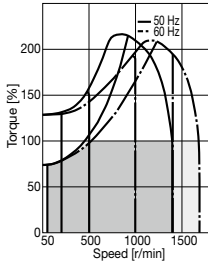

■ 200 V

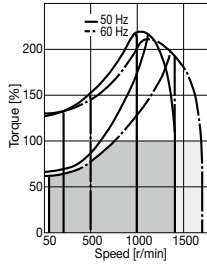

<1-Phase 25 W>

■ Frame Size 12, 22/100 V

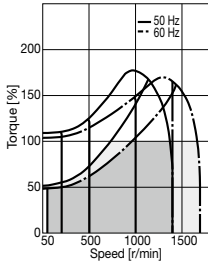

■ Frame Size 12, 22/200 V

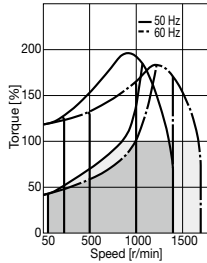

■ Frame Size 15, 28/100 V

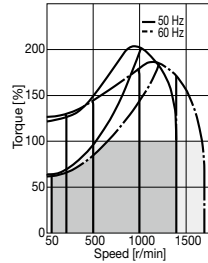

■ Frame Size 15, 28/200 V

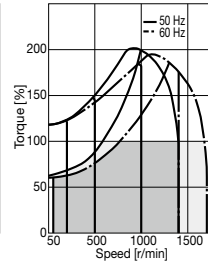

<1-Phase 40 W>

■ Frame Size 15, 28, 32/100 V

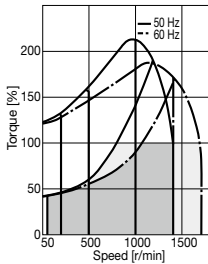

■ Frame Size 15, 28, 32/200 V

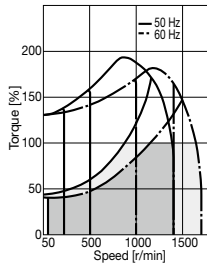

■ Frame Size 18/100 V

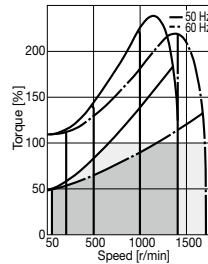

■ Frame Size 18/200 V

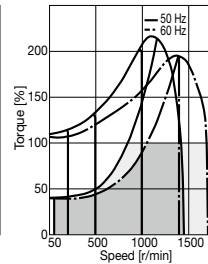

<1-Phase 60 W>

■ Frame Size 15, 28, 32/100 V

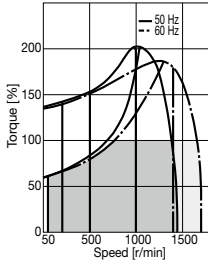

■ Frame Size 15, 28, 32/200 V

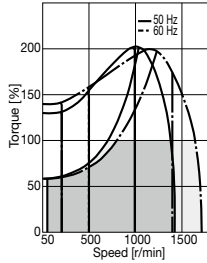

■ Frame Size 18/100 V

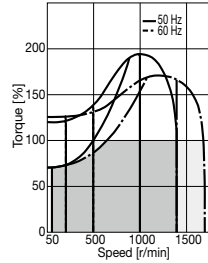

■ Frame Size 18/200 V

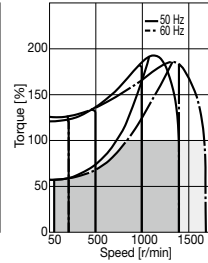

<1-Phase 90 W>

■ Frame Size 15, 28, 32/100 V

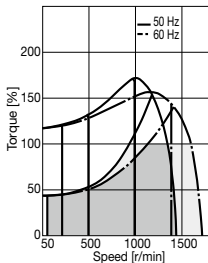

■ Frame Size 15, 28, 32/200 V

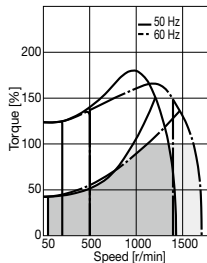

■ Frame Size 18, 40/100 V

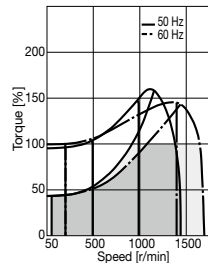

■ Frame Size 18, 40/200 V

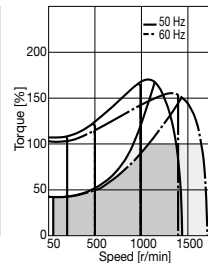

Note: 100 % torque represents the allowable output shaft torque at high speed.

G/G3 Type
 Parallel Shaft

H/H2 Type
 Right Angle Shaft

F Type
 Right Angle Hollow Bore/
 Right Angle Shaft

F2/F3 Type
 Concentric Right Angle Hollow Bore/
 Concentric Right Angle Shaft

Technical Documentation

4-3. Performance Table

[Notes]

- The output shaft speed is the value relative to the synchronous speed of the motor and the reduction ratio.
- The allowable output shaft torque at high speed represents the allowable output shaft torque in the high speed range (r/min).
- The value (%) of the allowable output shaft torque at 50 r/min represents the ratio to the allowable output shaft torque at high speed.
- Allowable output shaft O.H.L. is the value at the middle of the output shaft.
- The “*” mark indicates a limited torque type. Please make sure to check the allowable output shaft torque in the performance table.
-  in the performance table indicates that the shaft rotates clockwise when viewed from the output shaft side when the connection is made as shown on page 492 (CW). (Refer to the figure on the right)

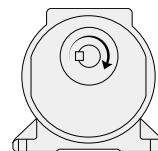

Series	Motor Power	Frame Size	Reduction Ratio	Actual Reduction Ratio	Output Shaft Speed		Allowable Output Shaft O.H.L.	Allowable Output Shaft Torque		Drawings		
					r/min			At High Speed	At 50 r/min (%)	Foot Mount	Flange Mount	Small Flange Mount
					50 Hz	60 Hz	N	N·m				
MINI	1-Phase 15 W	12	1/5	1/5	300	360	98	70	0.29	P.157	P.162	-
			1/7.5	1/7.5	200	240	196	0.49				
			1/10	1/10	150	180	245	0.69				
			1/15	1/15	100	120	343	0.98				
			1/20	1/20	75	90	441	1.27				
			1/25	1/25	60	72	490	1.67				
			1/30	1/29	50	60	539	1.96				
			1/40	1/40	37.5	45	588	2.65				
			1/50	1/50	30	36	637	3.33				
			1/60	1/58	25	30	686	3.92				
			1/80	1/80	18.8	22.5	735	5.00				
			1/100	1/100	15	18	735	6.27				
		1/120	1/120	12.5	15	784	7.45					
		1/160	1/160	9.4	11.2	784	9.80					
		1/200	1/200	7.5	9	784	12.7					
		1/240	1/232	6.3	7.5	784	14.7					
		1/300	91/27000	5	6	1760	16.7					
		1/375	11/4050	4	4.8	1760	20.6					
		1/450	637/297000	3.3	4	1760	25.5					
		1/600	91/54000	2.5	3	1760	33.3					
		1/750	11/8100	2	2.4	1760	42.1					
		1/900	637/594000	1.7	2	1760	50					
		1/1200	91/10440	1.3	1.5	1760	66.6					
		1/1500	11/15660	1	1.2	1760	83.3					
	1/1800	637/1148400	0.8	1	1760	98						
	1/5	1/5	300	360	98	0.59	P.157	P.162	-			
	1/7.5	1/7.5	200	240	196	0.78						
	1/10	1/10	150	180	245	1.08						
	1/15	1/15	100	120	343	1.67						
	1/20	1/20	75	90	441	2.25						
	1/25	1/25	60	72	490	2.74						
	1/30	1/29	50	60	539	3.33						
	1/40	1/40	37.5	45	588	4.41						
	1/50	1/50	30	36	637	5.49						
	1/60	1/58	25	30	686	6.66						
	1/80	1/80	18.8	22.5	735	8.43						
	1/100	1/100	15	18	735	10.8						
	1/120	1/120	12.5	15	784	12.7						
	1/160	1/160	9.4	11.2	1080	16.7						
	1/200	1/200	7.5	9	1080	20.6						
	1/240	1/232	6.3	7.5	1080	25.5						
	1/300	91/27000	5	6	1760	28.4	P.158	P.162	-			
	1/375	11/4050	4	4.8	1760	35.3						
	1/450	637/297000	3.3	4	1760	42.1						
	1/600	91/54000	2.5	3	1760	55.9	P.160	P.163	P.165			
	1/750	11/8100	2	2.4	1760	69.6						
	1/900	637/594000	1.7	2	1760	84.3						
	1/1200	221/249690	1.3	1.5	2740	108	P.160	P.164	P.166			
1/1500	187/261870	1	1.2	2740	137							
1/1800	169/285360	0.8	1	2740	167							

4-3. Performance Table

Series	Motor Power	Frame Size	Reduction Ratio	Actual Reduction Ratio	Output Shaft Speed		Allowable Output Shaft O.H.L.	Allowable Output Shaft Torque		Drawings		
					r/min			At High Speed	At 50 r/min (%)	Foot Mount	Flange Mount	Small Flange Mount
					50 Hz	60 Hz	N	N·m				
MINI	1-Phase 40 W	15	1/5	1/5	300	360	98	0.88	40 (100 V) (200 V)	P.158	P.162	-
			1/7.5	1/7.5	200	240	196	1.37				
			1/10	1/10	150	180	245	1.76				
			1/15	1/15	100	120	343	2.65				
			1/20	1/20	75	90	441	3.53				
			1/25	1/25	60	72	490	4.41				
			1/30	1/29	50	60	539	5.29				
			1/40	1/40	37.5	45	784	7.06				
			1/50	1/50	30	36	882	8.82				
			1/60	1/58	25	30	882	10.8				
			1/80	1/80	18.8	22.5	980	13.7				
			1/100	1/100	15	18	980	16.7				
		1/120	1/120	12.5	15	1080	20.6					
		18	1/160	1/160	9.4	11.2	1370	26.5	50 (100 V) 40 (200 V)	P.159	P.163	-
			1/200	1/200	7.5	9	1370	33.3				
			1/240	1/240	6.3	7.5	1370	40.2				
			1/300	91/27000	5	6	2740	45.1				
			1/375	11/4050	4	4.8	2740	55.9				
			1/450	637/297000	3.3	4	2740	67.6				
		28	1/600	221/129150	2.5	3	2740	90.2	40 (100 V) (200 V)	P.160	P.164	P.166
			1/750	187/135450	2	2.4	2740	118				
			1/900	169/147600	1.7	2	2740	137				
			1/1200	13/14964	1.3	1.5	5100	176				
			1/1500	11/15660	1	1.2	5100	225				
	1/1800		13/22446	0.8	1	5100	274					
	1-Phase 60 W	15	1/5	1/5	300	360	98	1.37	60 (100 V) 55 (200 V)	P.158	P.162	-
			1/7.5	1/7.5	200	240	196	2.06				
			1/10	1/10	150	180	245	2.74				
			1/15	1/15	100	120	343	4.12				
			1/20	1/20	75	90	441	5.49				
			1/25	1/25	60	72	490	6.96				
			1/30	1/29	50	60	539	8.33				
			1/40	1/40	37.5	45	784	10.8				
			1/50	1/50	30	36	882	13.7				
			1/60	1/58	25	30	882	16.7				
			1/80	1/80	18.8	22.5	1270	20.6				
			1/100	1/100	15	18	1270	26.5				
		1/120	1/120	12.5	15	1370	31.4					
		1/160	1/160	9.4	11.2	1370	42.1					
		1/200	1/200	7.5	9	1370	52.9					
		* 1/240	1/240	6.3	7.5	1370	53.9					
		28	1/300	91/27000	5	6	2740	70.6	60 (100 V) 55 (200 V)	P.160	P.164	P.166
			1/375	11/4050	4	4.8	2740	88.2				
			1/450	637/297000	3.3	4	2740	108				
			1/600	221/129150	2.5	3	2740	137				
			1/750	187/135450	2	2.4	2740	176				
			1/900	169/147600	1.7	2	2740	216				
		32	1/1200	13/14964	1.3	1.5	5100	284	60 (100 V) 55 (200 V)	P.161	P.164	P.166
1/1500			11/15660	1	1.2	5100	353					
1/1800	13/22446		0.8	1	5100	421						

G/G3 Type
Parallel Shaft

H/H2 Type
Right Angle Shaft

F Type
Right Angle Hollow Bore/
Right Angle Shaft

F2/F3 Type
Concentric Right Angle Hollow Bore/
Concentric Right Angle Shaft

Technical Documentation

Series	Motor Power	Frame Size	Reduction Ratio	Actual Reduction Ratio	Output Shaft Speed		Allowable Output Shaft O.H.L.	Allowable Output Shaft Torque		Drawings		
					r/min			At High Speed	At 50 r/min (%)	Foot Mount	Flange Mount	Small Flange Mount
					50 Hz	60 Hz	N	N·m				
MINI	1-Phase 90 W	15	1/5	1/5	300	360	147	2.06	40 (100 V) (200 V)	P.158	P.162	-
			1/7.5	1/7.5	200	240	245	3.14				
			1/10	1/10	150	180	343	4.12				
			1/15	1/15	100	120	441	6.17				
			1/20	1/20	75	90	539	8.33				
			1/25	1/25	60	72	588	10.8				
			1/30	1/29	50	60	686	12.7				
		18	1/40	1/40	37.5	45	1080	16.7	40 (100 V) (200 V)	P.159	P.163	-
			1/50	1/50	30	36	1180	20.6				
			1/60	1/60	25	30	1180	24.5				
			1/80	1/80	18.8	22.5	1270	31.4				
			1/100	1/100	15	18	1270	39.2				
			1/120	1/120	12.5	15	1370	47.0				
			* 1/160	1/160	9.4	11.2	1370	53.9				
		* 1/200	1/200	7.5	9	1370	53.9					
		* 1/240	1/240	6.3	7.5	1370	53.9					
		28	1/300	221/64575	5	6	2740	108	40 (100 V) (200 V)	P.160	P.164	P.166
			1/375	187/67725	4	4.8	2740	137				
			1/450	169/73800	3.3	4	2740	157				
		32	1/600	13/7740	2.5	3	5100	216	40 (100 V) (200 V)	P.161	P.164	P.166
			1/750	11/8100	2	2.4	5100	265				
			1/900	13/11610	1.7	2	5100	314				
		40	1/1200	13/14964	1.3	1.5	7060	421	40 (100 V) (200 V)	P.161	P.165	-
			1/1500	11/15660	1	1.2	7060	529				
1/1800	13/22443		0.8	1	7060	637						

Note 1: Please be sure to read the notes on page 154.

4-4. Drawings

G Type Parallel Shaft Shaft Diameter **12** Foot Mounting

<Figure 1>

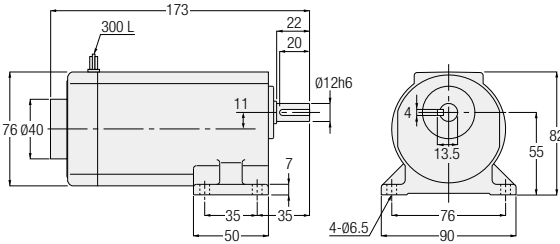

Number of Phases	Power	Part Number	Reduction Ratio	Figure Number	Controller	Approx. Weight (kg)
1-Phase	15 W	GLU-12-***-S15	5, 7.5, 10, 15, 20, 25, 30, 40, 50, 60, 80, 100, 120, 160, 200, 240	1	Set	2
		GLU-12-***-S15W				
		GLP-12-***-S15	5, 7.5, 10, 15, 20, 25, 30, 40, 50, 60, 80, 100, 120, 160, 200, 240	1	Sold Separately	2
	25 W	GLU-12-***-S25	5, 7.5, 10, 15, 20, 25, 30, 40, 50, 60, 80, 100, 120	1	Set	2
		GLU-12-***-S25W				
		GLP-12-***-S25	5, 7.5, 10, 15, 20, 25, 30, 40, 50, 60, 80, 100, 120	1	Sold Separately	2

Note: A reduction ratio will be indicated as *** in the nomenclature.
Note: Please refer to page 154 for the performance table.

G/G3 Type
Parallel Shaft

H/H2 Type
Right Angle Shaft

F Type
Right Angle Hollow Bore/
Right Angle Shaft

F2/F3 Type
Concentric Right Angle Hollow Bore/
Concentric Right Angle Shaft

Technical Documentation

G Type Parallel Shaft Shaft Diameter **15** **Foot Mounting**

<Figure 1>

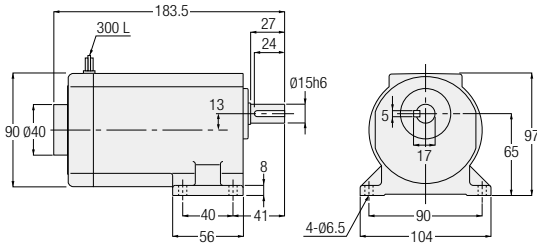

<Figure 2>

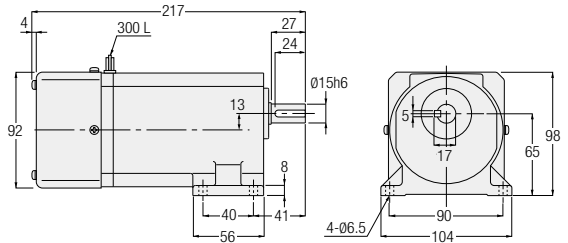

Number of Phases	Power	Part Number	Reduction Ratio	Figure Number	Controller	Approx. Weight (kg)	
1-Phase	25 W	GLU-15-***-S25	160, 200, 240	1	Set	3	
		GLU-15-***-S25W					
		GLP-15-***-S25	160, 200, 240	1	Sold Separately	3	
		GLP-15-***-S25W					
	40 W	GLU-15-***-S40	5, 7.5, 10, 15, 20, 25, 30, 40, 50, 60, 80, 100, 120	1	Set	3	
		GLU-15-***-S40W					
		GLP-15-***-S40	5, 7.5, 10, 15, 20, 25, 30, 40, 50, 60, 80, 100, 120	1	Sold Separately	3	
		GLP-15-***-S40W					
		60 W	GLU-15-***-S60	5, 7.5, 10, 15, 20, 25, 30, 40, 50, 60	2	Set	3
			GLU-15-***-S60W				
	GLP-15-***-S60		5, 7.5, 10, 15, 20, 25, 30, 40, 50, 60	2	Sold Separately	3	
	GLP-15-***-S60W						
90 W	GLU-15-***-S90	5, 7.5, 10, 15, 20, 25, 30	2	Set	3		
	GLU-15-***-S90W						
	GLP-15-***-S90	5, 7.5, 10, 15, 20, 25, 30	2	Sold Separately	3		
	GLP-15-***-S90W						

Note: A reduction ratio will be indicated as *** in the nomenclature.
 Note: Please refer to page 154 for the performance table.

G Type Parallel Shaft Shaft Diameter **18** Foot Mounting

<Figure 1>

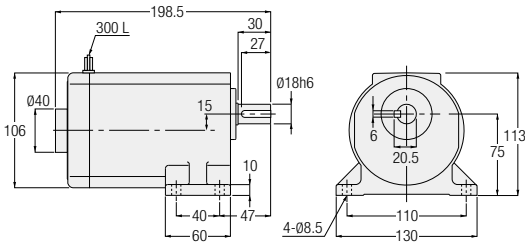

<Figure 2>

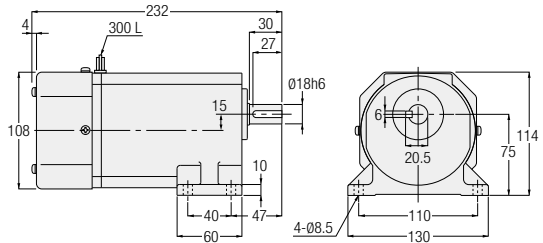

Number of Phases	Power	Part Number	Reduction Ratio	Figure Number	Controller	Approx. Weight (kg)
1-Phase	40 W	GLU-18-***-S40	160, 200, 240	1	Set	4
		GLU-18-***-S40W				
		GLP-18-***-S40	160, 200, 240	1	Sold Separately	4
		GLP-18-***-S40W				
	60 W	GLU-18-***-S60	80, 100, 120, 160, 200, 240	2	Set	4
		GLU-18-***-S60W				
		GLP-18-***-S60	80, 100, 120, 160, 200, 240	2	Sold Separately	4
		GLP-18-***-S60W				
	90 W	GLU-18-***-S90	40, 50, 60, 80, 100, 120, 160, 200, 240	2	Set	4
		GLU-18-***-S90W				
		GLP-18-***-S90	40, 50, 60, 80, 100, 120, 160, 200, 240	2	Sold Separately	4
		GLP-18-***-S90W				

Note: A reduction ratio will be indicated as *** in the nomenclature.
 Note: Please refer to page 155 for the performance table.

G/G3 Type Parallel Shaft

H/H2 Type Right Angle Shaft

F Type Right Angle Hollow Bore/ Right Angle Shaft

F2/F3 Type Concentric Right Angle Hollow Bore/ Concentric Right Angle Shaft

Technical Documentation

G Type Parallel Shaft Shaft Diameter **22** **Foot Mounting**

<Figure 1>

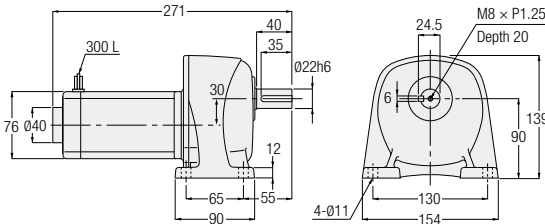

Number of Phases	Power	Part Number	Reduction Ratio	Figure Number	Controller	Approx. Weight (kg)
1-Phase	15 W	GLU-22-***-S15	300, 375, 450, 600, 750, 900, 1200, 1500, 1800	1	Set	5
		GLU-22-***-S15W				
	25 W	GLP-22-***-S15	300, 375, 450, 600, 750, 900, 1200, 1500, 1800	1	Sold Separately	5
		GLP-22-***-S15W				
		GLU-22-***-S25	300, 375, 450, 600, 750, 900	1	Set	5
		GLU-22-***-S25W				
		GLP-22-***-S25	300, 375, 450, 600, 750, 900	1	Sold Separately	5
		GLP-22-***-S25W				

Note: A reduction ratio will be indicated as *** in the nomenclature.
Note: Please refer to page 154 for the performance table.

G Type Parallel Shaft Shaft Diameter **28** **Foot Mounting**

<Figure 2>

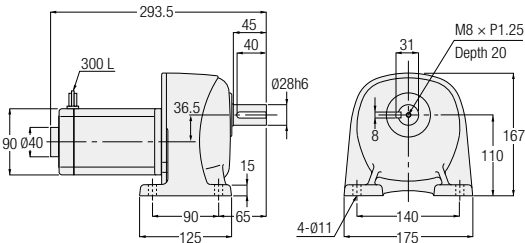

<Figure 3>

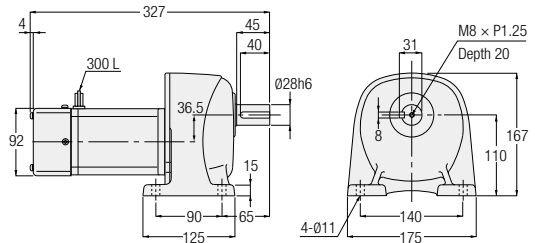

Number of Phases	Power	Part Number	Reduction Ratio	Figure Number	Controller	Approx. Weight (kg)
1-Phase	25 W	GLU-28-***-S25	1200, 1500, 1800	2	Set	7
		GLU-28-***-S25W				
		GLP-28-***-S25	1200, 1500, 1800	2	Sold Separately	7
		GLP-28-***-S25W				
	40 W	GLU-28-***-S40	300, 375, 450, 600, 750, 900	2	Set	7
		GLU-28-***-S40W				
		GLP-28-***-S40	300, 375, 450, 600, 750, 900	2	Sold Separately	7
	60 W	GLU-28-***-S60	300, 375, 450, 600, 750, 900	3	Set	7
		GLU-28-***-S60W				
		GLP-28-***-S60	300, 375, 450, 600, 750, 900	3	Sold Separately	7
	90 W	GLU-28-***-S90	300, 375, 450	3	Set	7
		GLU-28-***-S90W				
GLP-28-***-S90		300, 375, 450	3	Sold Separately	7	
		GLP-28-***-S90W				

Note: A reduction ratio will be indicated as *** in the nomenclature.
Note: Please refer to page 154 for the performance table.

G Type Parallel Shaft Shaft Diameter **32** Foot Mounting

<Figure 1>

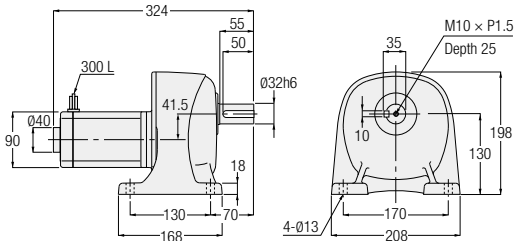

<Figure 2>

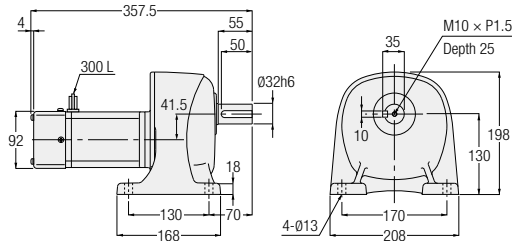

Number of Phases	Power	Part Number	Reduction Ratio	Figure Number	Controller	Approx. Weight (kg)
1-Phase	40 W	GLU-32-***-S40	1200, 1500, 1800	1	Set	11
		GLU-32-***-S40W				
		GLP-32-***-S40	1200, 1500, 1800	1	Sold Separately	11
	GLP-32-***-S40W					
	60 W	GLU-32-***-S60	1200, 1500, 1800	2	Set	11
		GLU-32-***-S60W				
		GLP-32-***-S60W	1200, 1500, 1800	2	Sold Separately	11
	90 W	GLU-32-***-S90	600, 750, 900	2	Set	11
		GLU-32-***-S90W				
GLP-32-***-S90		600, 750, 900	2	Sold Separately	11	
GLP-32-***-S90W						

Note: A reduction ratio will be indicated as *** in the nomenclature.
 Note: Please refer to page 155 for the performance table.

G Type Parallel Shaft Shaft Diameter **40** Foot Mounting

<Figure 3>

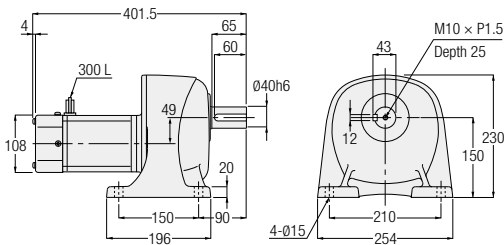

Number of Phases	Power	Part Number	Reduction Ratio	Figure Number	Controller	Approx. Weight (kg)
1-Phase	90 W	GLU-40-***-S90	1200, 1500, 1800	3	Set	15
		GLU-40-***-S90W				
		GLP-40-***-S90	1200, 1500, 1800	3	Sold Separately	15
		GLP-40-***-S90W				

Note: A reduction ratio will be indicated as *** in the nomenclature.
 Note: Please refer to page 156 for the performance table.

G/G3 Type Parallel Shaft

H/H2 Type Right Angle Shaft

F Type Right Angle Hollow Bore/ Right Angle Shaft

F2/F3 Type Concentric Right Angle Hollow Bore/ Concentric Right Angle Shaft

Technical Documentation

G Type Parallel Shaft Shaft Diameter **12** Flange Mounting

<Figure 1>

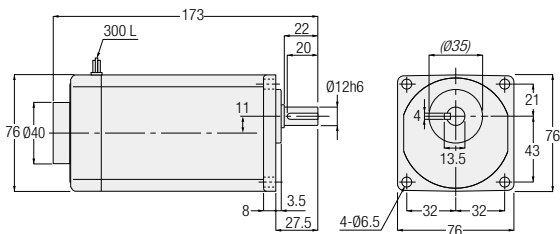

Note: The italic dimension indicates areas with remaining casting surface. Please add 0.5 mm or more to the italic dimension for the diameter of the mating hole.

Number of Phases	Power	Part Number	Reduction Ratio	Figure Number	Controller	Approx. Weight (kg)
1-Phase	15 W	GFU-12-***-S15	5, 7.5, 10, 15, 20, 25, 30, 40, 50, 60, 80, 100, 120, 160, 200, 240	1	Set	2
		GFP-12-***-S15	5, 7.5, 10, 15, 20, 25, 30, 40, 50, 60, 80, 100, 120, 160, 200, 240	1	Sold Separately	2
		GFU-12-***-S25	5, 7.5, 10, 15, 20, 25, 30, 40, 50, 60, 80, 100, 120	1	Set	2
	25 W	GFU-12-***-S25W	5, 7.5, 10, 15, 20, 25, 30, 40, 50, 60, 80, 100, 120	1	Set	2
		GFP-12-***-S25	5, 7.5, 10, 15, 20, 25, 30, 40, 50, 60, 80, 100, 120	1	Sold Separately	2
		GFP-12-***-S25W	5, 7.5, 10, 15, 20, 25, 30, 40, 50, 60, 80, 100, 120	1	Sold Separately	2

Note: A reduction ratio will be indicated as *** in the nomenclature.
Note: Please refer to page 154 for the performance table.

G Type Parallel Shaft Shaft Diameter **15** Flange Mounting

<Figure 2>

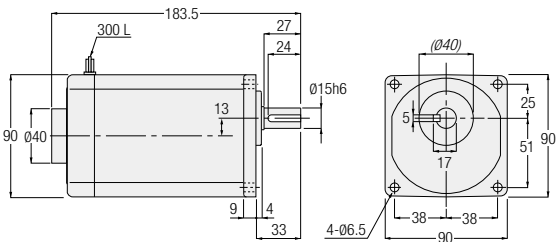

<Figure 3>

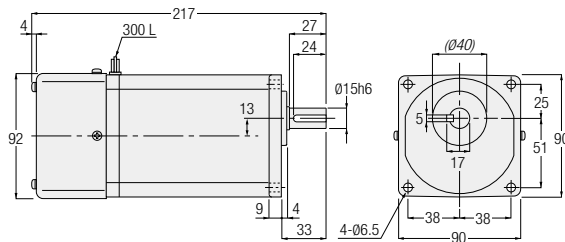

Note: The italic dimension indicates areas with remaining casting surface. Please add 0.5 mm or more to the italic dimension for the diameter of the mating hole.

Number of Phases	Power	Part Number	Reduction Ratio	Figure Number	Controller	Approx. Weight (kg)
1-Phase	25 W	GFU-15-***-S25	160, 200, 240	2	Set	3
		GFU-15-***-S25W	160, 200, 240	2	Sold Separately	3
		GFP-15-***-S25	160, 200, 240	2	Set	3
		GFP-15-***-S25W	160, 200, 240	2	Sold Separately	3
	40 W	GFU-15-***-S40	5, 7.5, 10, 15, 20, 25, 30, 40, 50, 60, 80, 100, 120	2	Set	3
		GFU-15-***-S40W	5, 7.5, 10, 15, 20, 25, 30, 40, 50, 60, 80, 100, 120	2	Sold Separately	3
		GFP-15-***-S40	5, 7.5, 10, 15, 20, 25, 30, 40, 50, 60, 80, 100, 120	2	Set	3
		GFP-15-***-S40W	5, 7.5, 10, 15, 20, 25, 30, 40, 50, 60, 80, 100, 120	2	Sold Separately	3
	60 W	GFU-15-***-S60	5, 7.5, 10, 15, 20, 25, 30, 40, 50, 60	3	Set	3
		GFU-15-***-S60W	5, 7.5, 10, 15, 20, 25, 30, 40, 50, 60	3	Sold Separately	3
		GFP-15-***-S60	5, 7.5, 10, 15, 20, 25, 30, 40, 50, 60	3	Set	3
		GFP-15-***-S60W	5, 7.5, 10, 15, 20, 25, 30, 40, 50, 60	3	Sold Separately	3
90 W	GFU-15-***-S90	5, 7.5, 10, 15, 20, 25, 30	3	Set	3	
	GFU-15-***-S90W	5, 7.5, 10, 15, 20, 25, 30	3	Sold Separately	3	
	GFP-15-***-S90	5, 7.5, 10, 15, 20, 25, 30	3	Set	3	
	GFP-15-***-S90W	5, 7.5, 10, 15, 20, 25, 30	3	Sold Separately	3	

Note: A reduction ratio will be indicated as *** in the nomenclature.
Note: Please refer to page 154 for the performance table.

G Type Parallel Shaft Shaft Diameter **18** Flange Mounting

<Figure 1>

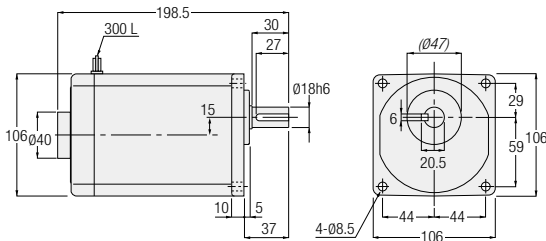

<Figure 2>

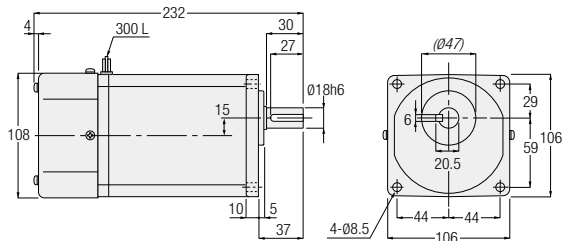

Note: The italic dimension indicates areas with remaining casting surface. Please add 0.5 mm or more to the italic dimension for the diameter of the mating hole.

Number of Phases	Power	Part Number	Reduction Ratio	Figure Number	Controller	Approx. Weight (kg)
1-Phase	40 W	GFU-18-***-S40	160, 200, 240	1	Set	4
		GFU-18-***-S40W				
		GFP-18-***-S40	160, 200, 240	1	Sold Separately	4
	60 W	GFU-18-***-S60	80, 100, 120, 160, 200, 240	2	Set	4
		GFU-18-***-S60W				
		GFP-18-***-S60	80, 100, 120, 160, 200, 240	2	Sold Separately	4
	90 W	GFU-18-***-S90	40, 50, 60, 80, 100, 120, 160, 200, 240	2	Set	4
		GFU-18-***-S90W				
		GFP-18-***-S90	40, 50, 60, 80, 100, 120, 160, 200, 240	2	Sold Separately	4

Note: A reduction ratio will be indicated as *** in the nomenclature.
Note: Please refer to page 155 for the performance table.

G Type Parallel Shaft Shaft Diameter **22** Flange Mounting

<Figure 3>

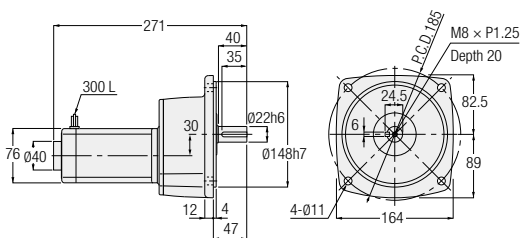

Number of Phases	Power	Part Number	Reduction Ratio	Figure Number	Controller	Approx. Weight (kg)
1-Phase	15 W	GFU-22-***-S15	300, 375, 450, 600, 750, 900, 1200, 1500, 1800	3	Set	5
		GFU-22-***-S15W				
		GFP-22-***-S15	300, 375, 450, 600, 750, 900, 1200, 1500, 1800	3	Sold Separately	5
	25 W	GFU-22-***-S25	300, 375, 450, 600, 750, 900	3	Set	5
		GFU-22-***-S25W				
		GFP-22-***-S25	300, 375, 450, 600, 750, 900	3	Sold Separately	5

Note: A reduction ratio will be indicated as *** in the nomenclature.
Note: Please refer to page 154 for the performance table.

G/G3 Type Parallel Shaft

H/H2 Type Right Angle Shaft

F Type Right Angle Hollow Bore/ Right Angle Shaft

F2/F3 Type Concentric Right Angle Hollow Bore/ Concentric Right Angle Shaft

Technical Documentation

G Type Parallel Shaft Shaft Diameter **28** **Flange Mounting**

<Figure 1>

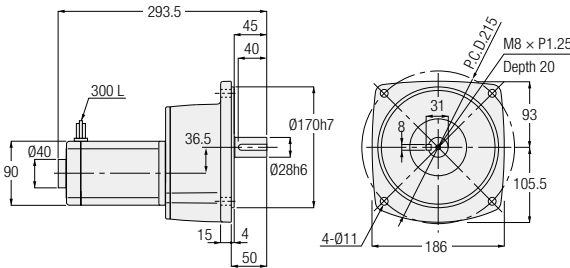

<Figure 2>

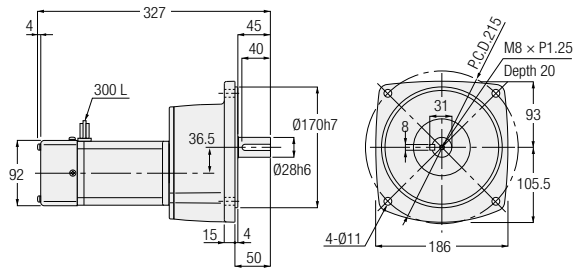

Number of Phases	Power	Part Number	Reduction Ratio	Figure Number	Controller	Approx. Weight (kg)
1-Phase	25 W	GFU-28-***-S25	1200, 1500, 1800	1	Set	7
		GFU-28-***-S25W				
		GFP-28-***-S25	1200, 1500, 1800	1	Sold Separately	7
		GFP-28-***-S25W				
	40 W	GFU-28-***-S40	300, 375, 450, 600, 750, 900	1	Set	7
		GFU-28-***-S40W				
		GFP-28-***-S40	300, 375, 450, 600, 750, 900	1	Sold Separately	7
		GFP-28-***-S40W				
	60 W	GFU-28-***-S60	300, 375, 450, 600, 750, 900	2	Set	7
		GFU-28-***-S60W				
		GFP-28-***-S60	300, 375, 450, 600, 750, 900	2	Sold Separately	7
		GFP-28-***-S60W				
90 W	GFU-28-***-S90	300, 375, 450	2	Set	7	
	GFU-28-***-S90W					
	GFP-28-***-S90	300, 375, 450	2	Sold Separately	7	
	GFP-28-***-S90W					

Note: A reduction ratio will be indicated as *** in the nomenclature.
 Note: Please refer to page 154 for the performance table.

G Type Parallel Shaft Shaft Diameter **32** **Flange Mounting**

<Figure 3>

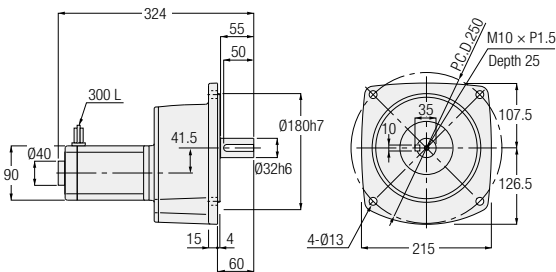

<Figure 4>

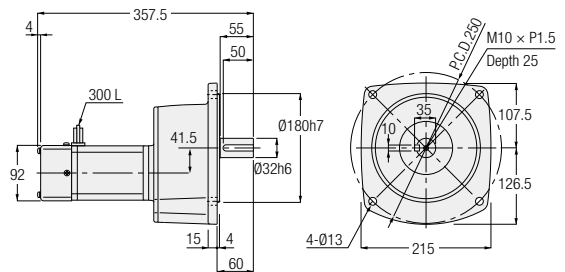

Number of Phases	Power	Part Number	Reduction Ratio	Figure Number	Controller	Approx. Weight (kg)
1-Phase	40 W	GFU-32-***-S40	1200, 1500, 1800	3	Set	11
		GFU-32-***-S40W				
		GFP-32-***-S40	1200, 1500, 1800	3	Sold Separately	11
		GFP-32-***-S40W				
	60 W	GFU-32-***-S60	1200, 1500, 1800	4	Set	11
		GFU-32-***-S60W				
		GFP-32-***-S60	1200, 1500, 1800	4	Sold Separately	11
		GFP-32-***-S60W				
	90 W	GFU-32-***-S90	600, 750, 900	4	Set	11
		GFU-32-***-S90W				
		GFP-32-***-S90	600, 750, 900	4	Sold Separately	11
		GFP-32-***-S90W				

Note: A reduction ratio will be indicated as *** in the nomenclature.
 Note: Please refer to page 155 for the performance table.

G Type Parallel Shaft Shaft Diameter **40** **Flange Mounting**

<Figure 1>

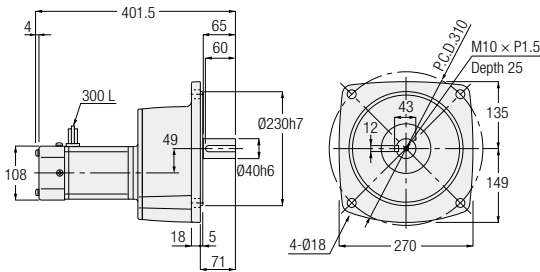

Number of Phases	Power	Part Number	Reduction Ratio	Figure Number	Controller	Approx. Weight (kg)
1-Phase	90 W	GFU-40-***-S90	1200, 1500, 1800	1	Set	15
		GFU-40-***-S90W				
		GFP-40-***-S90	1200, 1500, 1800	1	Sold Separately	15
		GFP-40-***-S90W				

Note: A reduction ratio will be indicated as *** in the nomenclature.
 Note: Please refer to page 156 for the performance table.

G Type Parallel Shaft Shaft Diameter **22** **Small Flange Mounting**

<Figure 2>

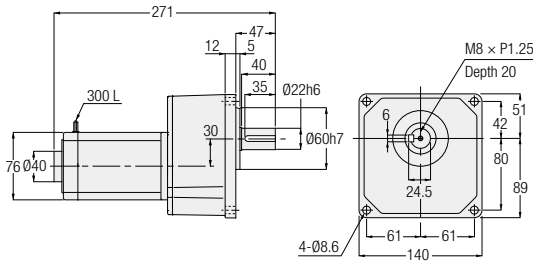

Number of Phases	Power	Part Number	Reduction Ratio	Figure Number	Controller	Approx. Weight (kg)
1-Phase	15 W	GKU-22-***-S15	300, 375, 450, 600, 750, 900, 1200, 1500, 1800	2	Set	5
		GKU-22-***-S15W				
		GKP-22-***-S15	300, 375, 450, 600, 750, 900, 1200, 1500, 1800	2	Sold Separately	5
		GKP-22-***-S15W				
	25 W	GKU-22-***-S25	300, 375, 450, 600, 750, 900	2	Set	5
		GKU-22-***-S25W				
GKP-22-***-S25		300, 375, 450, 600, 750, 900				
GKP-22-***-S25W						

Note: A reduction ratio will be indicated as *** in the nomenclature.
 Note: Please refer to page 154 for the performance table.

G/G3 Type Parallel Shaft

H/H2 Type Right Angle Shaft

F Type Right Angle Hollow Bore/ Right Angle Shaft

F2/F3 Type Concentric Right Angle Hollow Bore/ Concentric Right Angle Shaft

Technical Documentation

G Type Parallel Shaft Shaft Diameter **28** **Small Flange Mounting**

<Figure 1>

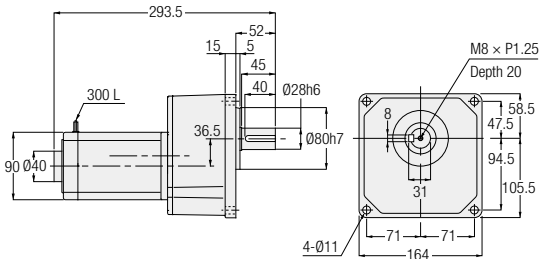

<Figure 2>

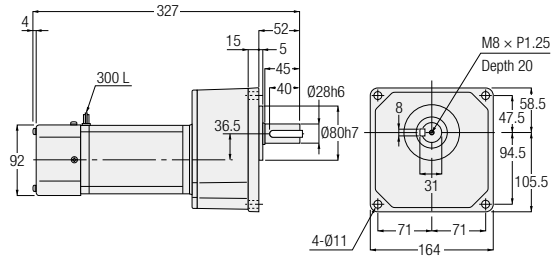

Number of Phases	Power	Part Number	Reduction Ratio	Figure Number	Controller	Approx. Weight (kg)
1-Phase	25 W	GKU-28-***-S25	1200, 1500, 1800	1	Set	7
		GKU-28-***-S25W	1200, 1500, 1800	1	Sold Separately	7
		GKP-28-***-S25	1200, 1500, 1800	1	Sold Separately	7
		GKP-28-***-S25W	1200, 1500, 1800	1	Sold Separately	7
	40 W	GKU-28-***-S40	300, 375, 450, 600, 750, 900	1	Set	7
		GKU-28-***-S40W	300, 375, 450, 600, 750, 900	1	Sold Separately	7
		GKP-28-***-S40	300, 375, 450, 600, 750, 900	1	Sold Separately	7
		GKP-28-***-S40W	300, 375, 450, 600, 750, 900	1	Sold Separately	7
	60 W	GKU-28-***-S60	300, 375, 450, 600, 750, 900	2	Set	7
		GKU-28-***-S60W	300, 375, 450, 600, 750, 900	2	Sold Separately	7
		GKP-28-***-S60	300, 375, 450, 600, 750, 900	2	Sold Separately	7
		GKP-28-***-S60W	300, 375, 450, 600, 750, 900	2	Sold Separately	7
90 W	GKU-28-***-S90	300, 375, 450	2	Set	7	
	GKU-28-***-S90W	300, 375, 450	2	Sold Separately	7	
	GKP-28-***-S90	300, 375, 450	2	Sold Separately	7	
	GKP-28-***-S90W	300, 375, 450	2	Sold Separately	7	

Note: A reduction ratio will be indicated as *** in the nomenclature.
 Note: Please refer to page 154 for the performance table.

G Type Parallel Shaft Shaft Diameter **32** **Small Flange Mounting**

<Figure 3>

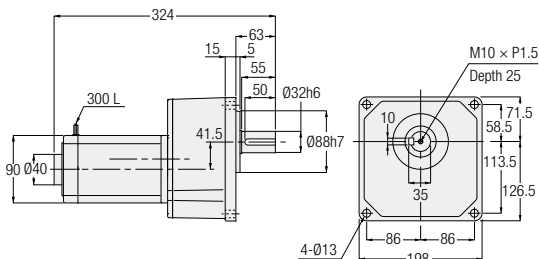

<Figure 4>

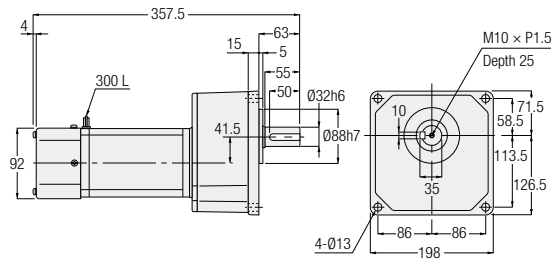

Number of Phases	Power	Part Number	Reduction Ratio	Figure Number	Controller	Approx. Weight (kg)
1-Phase	40 W	GKU-32-***-S40	1200, 1500, 1800	3	Set	11
		GKU-32-***-S40W	1200, 1500, 1800	3	Sold Separately	11
		GKP-32-***-S40	1200, 1500, 1800	3	Sold Separately	11
		GKP-32-***-S40W	1200, 1500, 1800	3	Sold Separately	11
	60 W	GKU-32-***-S60	1200, 1500, 1800	4	Set	11
		GKU-32-***-S60W	1200, 1500, 1800	4	Sold Separately	11
		GKP-32-***-S60	1200, 1500, 1800	4	Sold Separately	11
		GKP-32-***-S60W	1200, 1500, 1800	4	Sold Separately	11
	90 W	GKU-32-***-S90	600, 750, 900	4	Set	11
		GKU-32-***-S90W	600, 750, 900	4	Sold Separately	11
		GKP-32-***-S90	600, 750, 900	4	Sold Separately	11
		GKP-32-***-S90W	600, 750, 900	4	Sold Separately	11

Note: A reduction ratio will be indicated as *** in the nomenclature.
 Note: Please refer to page 155 for the performance table.

MEMO

G/G3 Type
Parallel Shaft

H/H2 Type
Right Angle Shaft

F Type
Right Angle Hollow Bore/
Right Angle Shaft

F2/F3 Type
Concentric Right Angle Hollow Bore/
Concentric Right Angle Shaft

Technical Documentation

5. Reducers (Double Shaft Type)

5-1. Performance Table

G3 Type Reducers (Double Shaft Type)

[Notes]

- Allowable output shaft O.H.L. is the value at the middle of the output shaft.
- For the rotational direction of the output shaft, please refer to the figure shown below.
- The “*” mark indicates a limited torque type. Please make sure to check the allowable output shaft torque in the performance table.
- The motor power class value is the value when a 4 pole motor is used.

■ Rotational Direction Relationship

The rotational direction shown below with arrow illustrates the rotation relationship between the output shaft / input shaft and is no way illustrating limitations in rotational direction.

Power	Reduction Ratio
0.1 kW	1/5 to 1/50 and 1/300 to 1/1200
0.2 kW, 0.4 kW	1/5 to 1/30 and 1/300 to 1/1200
0.75 kW	1/5 to 1/30 and 1/300 to 1/450
1.5 kW, 2.2 kW	1/5 to 1/30

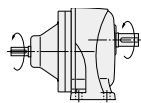

The input and output shafts rotate in the same direction.

Power	Reduction Ratio
0.1 kW	1/60 to 1/200
0.2 kW, 0.4 kW	1/40 to 1/200
0.75 kW, 1.5 kW	1/40 to 1/200
2.2 kW	1/40 to 1/100

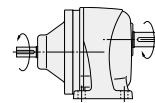

The input and output shafts rotate in the opposite directions.

4 Poles Motor Power Class	Frame Size	Reduction Ratio	Actual Reduction Ratio	Allowable Output Shaft Torque Input (1500 r/min)	Allowable O.H.L.		Drawings		
					N		Foot Mount	Flange Mount	Small Flange Mount
					Input Shaft	Output Shaft			
0.1 kW	18	1/5	33/164	3	176	770	P.170	P.173	P.176
		1/10	77/779	6.1		1140			
		1/15	119/1804	9.1		1270			
		1/20	49/984	12		1530			
		1/25	28/697	15		1650			
		1/30	35/1066	19		1780			
		1/40	35/1404	24		1910			
		1/50	7/351	29		2040			
	22	1/60	11/684	35	176	2800	P.170	P.173	P.176
		1/80	21/1634	47		3180			
		1/100	7/684	59		3180			
		1/120	147/17974	71		3180			
		1/160	21/3268	94		3180			
		1/200	21/4085	117		3180			
		1/300	221/65190	157		3430			
		1/450	187/68370	196		3430			
	28	1/300	221/65190	157	176	3430	P.171	P.174	P.177
		1/375	187/68370	196		3430			
		1/450	1183/521520	235		3430			
		1/600	147/88192	313		5880			
		1/750	49/36464	391		5880			
		* 1/900	62/57063	431		5880			
		* 1/1200	46/55195	431		5880			
		1/5	33/164	6.1		196			
1/10	77/779	11.8	1140						
1/15	119/1804	18.6	1270						
1/20	49/984	24.5	1450						
1/25	28/697	30.4	1550						
1/30	7/216	36.3	2280						
1/40	91/3600	47	2410						
1/50	11/540	58.8	2540						
22	1/60	637/39600	70.6	196	2800	P.170	P.173	P.176	
	1/80	91/7200	94.1		3000				
	* 1/100	11/1080	97		3180				
	1/100	13/1353	117		3690				
	1/120	91/11000	140		4320				
	1/160	1/165	187		4450				
	1/200	7/1375	234		4450				
	1/300	91/27348	313		5880				
28	1/375	77/28620	391	196	5880	P.171	P.174	P.177	
	1/450	91/41022	431		5880				
	1/600	9/5300	626		7060				
	* 1/750	62/46427	764		7060				
	* 1/900	23/21259	764		7060				
	* 1/1200	9/10600	764		7060				
	1/600	9/5300	626		7060				
	1/750	62/46427	764		7060				
40	* 1/900	23/21259	764	196	7060	P.172	P.175	-	
	* 1/1200	9/10600	764		7060				

5-1. Performance Table

4 Poles Motor Power Class	Frame Size	Reduction Ratio	Actual Reduction Ratio	Allowable Output Shaft Torque Input (1500 r/min)	Allowable O.H.L.		Drawings						
					N		Foot Mount	Flange Mount	Small Flange Mount				
					Input Shaft	Output Shaft							
0.4 kW	22	1/5	7/34	12	245	1140	P.170	P.173	P.176				
		1/10	7/68	25		1530							
		1/15	49/748	36		1780							
		1/20	7/136	48		1910							
		1/25	7/170	61		2050							
	28	1/30	1/30	73	245	3310	P.171	P.174	P.177				
		1/40	221/8610	94		3690							
		1/50	187/9030	117		4080							
		1/60	169/9840	140		4450							
		1/80	65/5166	187		4450							
		* 1/100	55/5418	193		4450							
		1/100	7/688	234		6370							
	32	1/120	77/9360	281	245	7640	P.171	P.174	P.177				
		1/160	21/3328	374		7640							
		1/200	189/38272	431		7640							
		1/300	7/2160	626		7060							
	40	* 1/375	77/29328	764	245	7060	P.172	P.175	-				
		* 1/450	49/21600	764		7060							
		* 1/600	57/35360	1225		9800							
	50	* 1/750	25/19448	1225	245	9800	P.172	P.175	-				
		* 1/900	5/4338	1225		9800							
		* 1/1200	33/40664	1225		9800							
		1/5	91/459	23		294				1650	P.171	P.174	P.177
		1/10	1/10	45						2280			
1/15	91/1360	68	2800										
1/20	5/102	91	3050										
1/25	7/170	114	3180										
0.75 kW	32	1/30	3/92	136	294	5220	P.171	P.174	P.177				
		1/40	13/516	175		5470							
		1/50	11/540	220		5780							
		1/60	13/774	264		6080							
		1/80	13/1032	351		6180							
	* 1/100	11/1080	362	6770									
	40	1/100	91/9000	439	294	9170	P.172	P.175	-				
		1/120	77/9400	527		9170							
		1/160	9/1400	703		9170							
	50	1/200	9/1750	764	294	9170	P.172	P.175	-				
1/300		211/62013	1176	9800									
* 1/375		94/36103	1225	9800									
* 1/450	65/29167	1225	9800										
1.5 kW	32	1/5	1/5	45	343	2280	P.171	P.174	P.177				
		1/10	1/10	91		3180							
		1/15	1/15	136		3690							
		1/20	1/20	181		4190							
		1/25	9/230	226		4410							
	40	1/30	1/30	272	343	6600	P.172	P.175	-				
		1/40	13/540	351		6960							
		1/50	11/564	439		6960							
		1/60	91/5400	527		7210							
		1/80	13/1080	703		7400							
	* 1/100	11/1128	724	7400									
	50	1/100	25/2618	878	343	12500	P.172	P.175	-				
		1/120	77/8993	1060		12500							
		* 1/160	33/5474	1230		12500							
		* 1/200	30/5831	1230		12500							
1/5		7/36	66	392		2800				P.172	P.175	-	
1/10	7/72	131	4080										
1/15	49/720	197	4580										
1/20	7/144	264	5220										
1/25	7/180	329	6110										
2.2 kW	40	1/30	5/154	395	392	9040	P.172	P.175	-				
		1/40	399/15488	499		9420							
		1/50	399/20240	623		10000							
		1/60	49/2904	748		10000							
		1/80	49/3795	1000		10100							
	* 1/100	21/2116	1230	10100									

G/G3 Type
Parallel Shaft

H/H2 Type
Right Angle Shaft

F Type
Right Angle Hollow Bore/
Right Angle Shaft

F2/F3 Type
Concentric Right Angle Hollow Bore/
Concentric Right Angle Shaft

Technical Documentation

5-2. Drawings

G3 Type Parallel Shaft Shaft Diameter **18** Foot Mounting

<Figure 1>

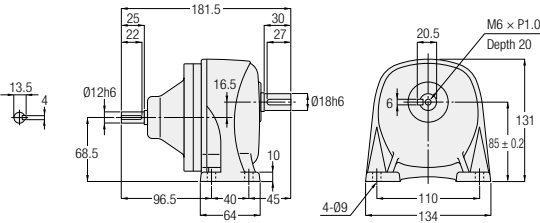

Power Class	Part Number	Reduction Ratio	Figure Number	Approx. Weight (kg)
0.1 kW	G3L-18-***-010	5, 10, 15, 20, 25, 30, 40, 50	1	2.5
0.2 kW	G3L-18-***-020	5, 10, 15, 20, 25	1	2.5

Note: A reduction ratio will be indicated as *** in the nomenclature.
 Note: Please refer to page 168 for the performance table.

G3 Type Parallel Shaft Shaft Diameter **22** Foot Mounting

<Figure 2>

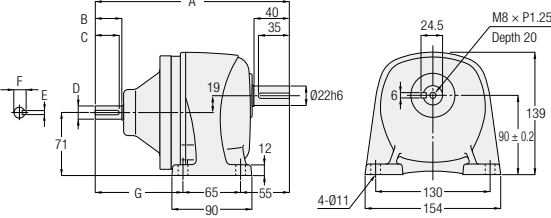

Power Class	Part Number	Reduction Ratio	Figure Number	Approx. Weight (kg)	A	B	C	D	E	F	G
0.1 kW	G3L-22-***-010	60, 80, 100, 120, 160, 200	2	3.5	207.5	25	22	012h6	4	13.5	87.5
0.2 kW	G3L-22-***-020	30, 40, 50, 60, 80, 100	2	3.5	207.5	25	22	012h6	4	13.5	87.5
0.4 kW	G3L-22-***-040	5, 10, 15, 20, 25	2	4	219	30	27	015h6	5	17	99

Note: A reduction ratio will be indicated as *** in the nomenclature.
 Note: Please refer to page 168 for the performance table.

G3 Type Parallel Shaft Shaft Diameter **28** Foot Mounting

<Figure 1>

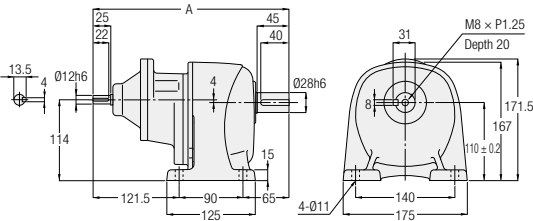

<Figure 2>

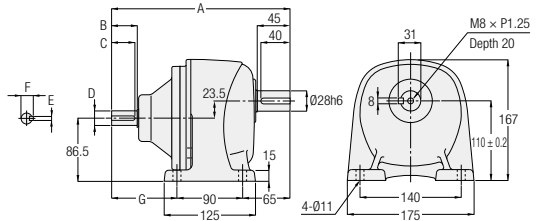

Power Class	Part Number	Reduction Ratio	Figure Number	Approx. Weight (kg)	A	B	C	D	E	F	G
0.1 kW	G3L-28-***-010	300, 375, 450	1	6.5	276.5	-	-	-	-	-	-
0.2 kW	G3L-28-***-020	100, 120, 160, 200	2	5.5	220.5	25	22	Ø12h6	4	13.5	65.5
0.4 kW	G3L-28-***-040	30, 40, 50, 60, 80, 100	2	6	235	30	27	Ø15h6	5	17	80
0.75 kW	G3L-28-***-075	5, 10, 15, 20, 25	2	6	244.5	35	32	Ø20h6	6	22.5	89.5

Note: A reduction ratio will be indicated as *** in the nomenclature.
 Note: Please refer to page 168 for the performance table.

G3 Type Parallel Shaft Shaft Diameter **32** Foot Mounting

<Figure 3>

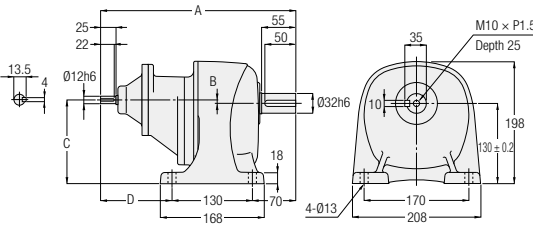

<Figure 4>

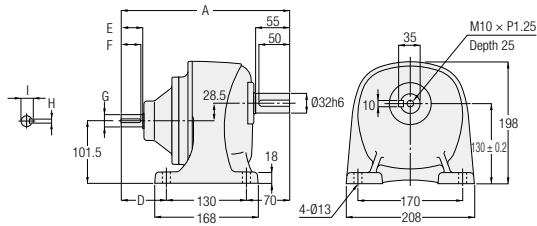

Power Class	Part Number	Reduction Ratio	Figure Number	Approx. Weight (kg)	A	B	C	D	E	F	G	H	I
0.1 kW	G3L-32-***-010	600, 750, 900, 1200	3	9.5	295.5	-1	129	95.5	-	-	-	-	-
0.2 kW	G3L-32-***-020	300, 375, 450	3	9.5	315.5	5.5	135.5	115.5	-	-	-	-	-
0.4 kW	G3L-32-***-040	100, 120, 160, 200	4	9	254	-	-	54	30	27	Ø15h6	5	17
0.75 kW	G3L-32-***-075	30, 40, 50, 60, 80, 100	4	9.5	273.5	-	-	73.5	35	32	Ø20h6	6	22.5
1.5 kW	G3L-32-***-150	5, 10, 15, 20, 25	4	10	297	-	-	97	40	35	Ø25h6	8	28

Note: A reduction ratio will be indicated as *** in the nomenclature.
 Note: Please refer to page 168 for the performance table.

G3 Type Parallel Shaft **Shaft Diameter 40** **Foot Mounting**

<Figure 1>

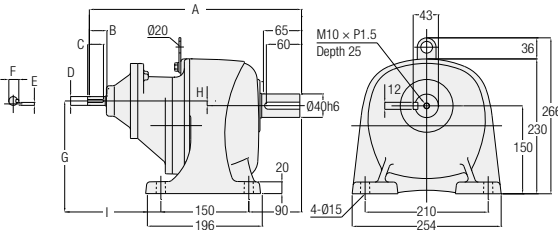

<Figure 2>

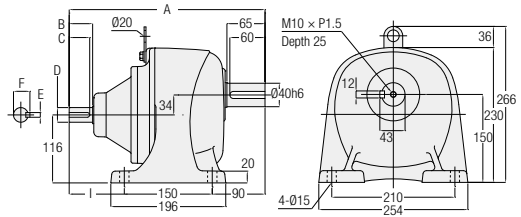

Note: Gearmotors with a motor power of 0.2 kW or 0.75 kW does not include the hanging plate.

Power Class	Part Number	Reduction Ratio	Figure Number	Approx. Weight (kg)	A	B	C	D	E	F	G	H	I
0.2 kW	G3L-40-***-020	600, 750, 900, 1200	1	16	337.5	25	22	Ø12h6	4	13.5	150	0	97.5
0.4 kW	G3L-40-***-040	300, 375, 450	1	17.5	362	30	27	Ø15h6	5	17	158	8	122
0.75 kW	G3L-40-***-075	100, 120, 160, 200	2	16	295.5	35	32	Ø20h6	6	22.5	-	-	55.5
1.5 kW	G3L-40-***-150	30, 40, 50, 60, 80, 100	2	17	334	40	35	Ø25h6	8	28	-	-	94
2.2 kW	G3L-40-***-220	5, 10, 15, 20, 25	2	16.5	330	45	40	Ø30h6	8	33	-	-	90

Note: A reduction ratio will be indicated as *** in the nomenclature.
Note: Please refer to page 168 for the performance table.

G3 Type Parallel Shaft **Shaft Diameter 50** **Foot Mounting**

<Figure 3>

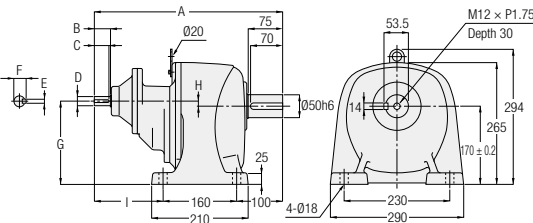

<Figure 4>

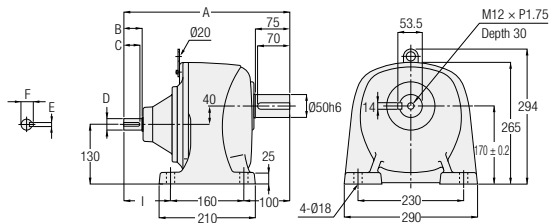

Power Class	Part Number	Reduction Ratio	Figure Number	Approx. Weight (kg)	A	B	C	D	E	F	G	H	I
0.4 kW	G3L-50-***-040	600, 750, 900, 1200	3	47	390	30	27	Ø15h6	5	17	172	2	130
0.75 kW	G3L-50-***-075	300, 375, 450	3	47.5	409.5	35	32	Ø20h6	6	22.5	181	11	149.5
1.5 kW	G3L-50-***-150	100, 120, 160, 200	4	46.5	362	40	35	Ø25h6	8	28	-	-	102
2.2 kW	G3L-50-***-220	30, 40, 50, 60, 80, 100	4	46.5	374	45	40	Ø30h6	8	33	-	-	114

Note: A reduction ratio will be indicated as *** in the nomenclature.
Note: Please refer to page 169 for the performance table.

G3 Type Parallel Shaft Shaft Diameter **18** Flange Mounting

<Figure 1>

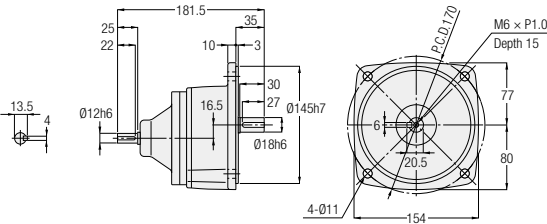

Power Class	Part Number	Reduction Ratio	Figure Number	Approx. Weight (kg)
0.1 kW	G3F-18-***-010	5, 10, 15, 20, 25, 30, 40, 50	1	3
0.2 kW	G3F-18-***-020	5, 10, 15, 20, 25	1	3

Note: A reduction ratio will be indicated as *** in the nomenclature.
 Note: Please refer to page 168 for the performance table.

G Type Parallel Shaft Shaft Diameter **22** Flange Mounting

<Figure 2>

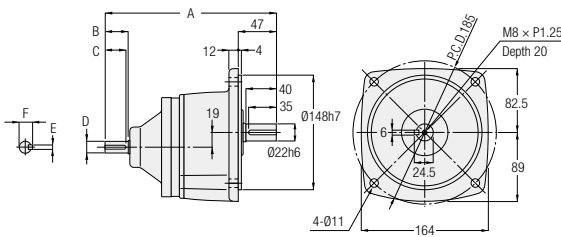

Power Class	Part Number	Reduction Ratio	Figure Number	Approx. Weight (kg)	A	B	C	D	E	F
0.1 kW	G3F-22-***-010	60, 80, 100, 120, 160, 200	2	4	207.5	25	22	Ø12h6	4	13.5
0.2 kW	G3F-22-***-020	30, 40, 50, 60, 80, 100	2	4	207.5	25	22	Ø12h6	4	13.5
0.4 kW	G3F-22-***-040	5, 10, 15, 20, 25	2	4.5	219	30	27	Ø15h6	5	17

Note: A reduction ratio will be indicated as *** in the nomenclature.
 Note: Please refer to page 168 for the performance table.

G/G3 Type Parallel Shaft

H/H2 Type Right Angle Shaft

F Type Right Angle Hollow Bore/ Right Angle Shaft

F2/F3 Type Concentric Right Angle Hollow Bore/ Concentric Right Angle Shaft

Technical Documentation

G3 Type Parallel Shaft Shaft Diameter **28** Flange Mounting

<Figure 1>

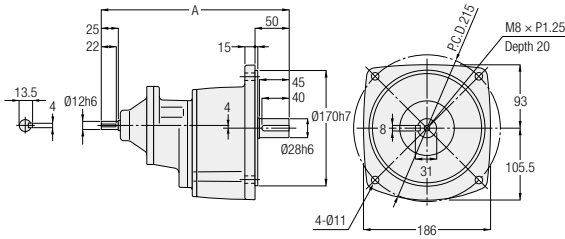

<Figure 2>

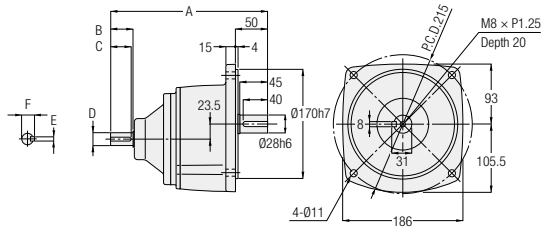

Power Class	Part Number	Reduction Ratio	Figure Number	Approx. Weight (kg)	A	B	C	D	E	F
0.1 kW	G3F-28-***-010	300, 375, 450	1	7	276.5	-	-	-	-	-
0.2 kW	G3F-28-***-020	100, 120, 160, 200	2	6	220.5	25	22	Ø12h6	4	13.5
0.4 kW	G3F-28-***-040	30, 40, 50, 60, 80, 100	2	6.5	235	30	27	Ø15h6	5	17
0.75 kW	G3F-28-***-075	5, 10, 15, 20, 25	2	6.5	244.5	35	32	Ø20h6	6	22.5

Note: A reduction ratio will be indicated as *** in the nomenclature.
 Note: Please refer to page 168 for the performance table.

G3 Type Parallel Shaft Shaft Diameter **32** Flange Mounting

<Figure 3>

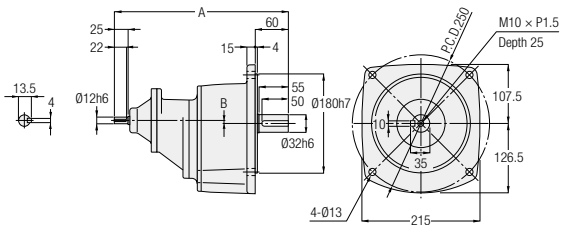

<Figure 4>

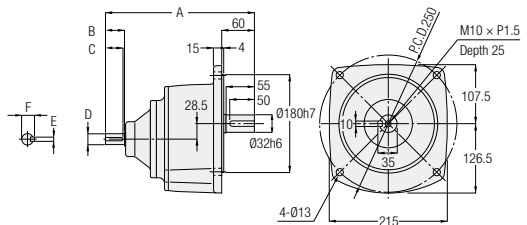

Power Class	Part Number	Reduction Ratio	Figure Number	Approx. Weight (kg)	A	B	C	D	E	F
0.1 kW	G3F-32-***-010	600, 750, 900, 1200	3	10	295.5	-1	-	-	-	-
0.2 kW	G3F-32-***-020	300, 375, 450	3	10	315.5	5.5	-	-	-	-
0.4 kW	G3F-32-***-040	100, 120, 160, 200	4	9.5	254	30	27	Ø15h6	5	17
0.75 kW	G3F-32-***-075	30, 40, 50, 60, 80, 100	4	10	273.5	35	32	Ø20h6	6	22.5
1.5 kW	G3F-32-***-150	5, 10, 15, 20, 25	4	10.5	297	40	35	Ø25h6	8	28

Note: A reduction ratio will be indicated as *** in the nomenclature.
 Note: Please refer to page 168 for the performance table.

G3 Type Parallel Shaft Shaft Diameter **40** Flange Mounting

<Figure 1>

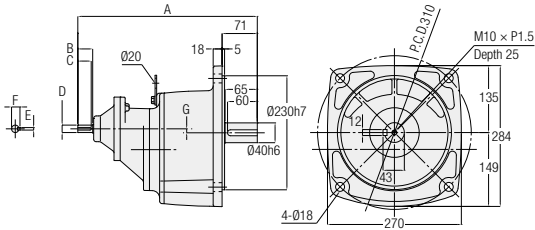

<Figure 2>

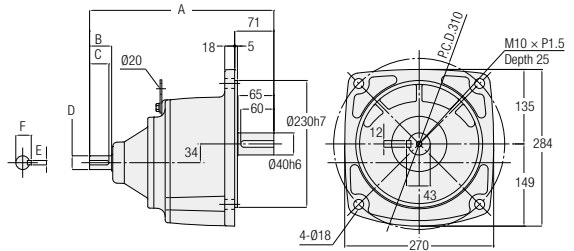

Note: Gearmotors with a motor power of 0.2 kW or 0.75 kW does not include the hanging plate.

Power Class	Part Number	Reduction Ratio	Figure Number	Approx. Weight (kg)	A	B	C	D	E	F	G
0.2 kW	G3F-40-***-020	600, 750, 900, 1200	1	17.5	337.5	25	22	Ø12h6	4	13.5	0
0.4 kW	G3F-40-***-040	300, 375, 450	1	19	362	30	27	Ø15h6	5	17	8
0.75 kW	G3F-40-***-075	100, 120, 160, 200	2	17.5	295.5	35	32	Ø20h6	6	22.5	-
1.5 kW	G3F-40-***-150	30, 40, 50, 60, 80, 100	2	18.5	334	40	35	Ø25h6	8	28	-
2.2 kW	G3F-40-***-220	5, 10, 15, 20, 25	2	18	330	45	40	Ø30h6	8	33	-

Note: A reduction ratio will be indicated as *** in the nomenclature.
Note: Please refer to page 168 for the performance table.

G Type Parallel Shaft Shaft Diameter **50** Flange Mounting

<Figure 3>

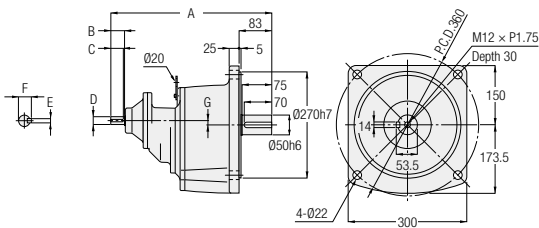

<Figure 4>

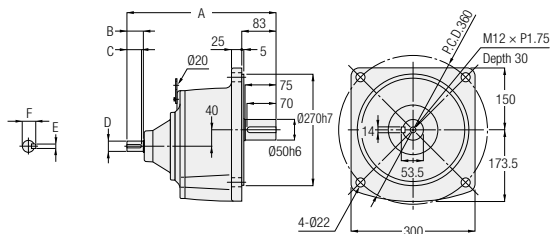

Power Class	Part Number	Reduction Ratio	Figure Number	Approx. Weight (kg)	A	B	C	D	E	F	G
0.4 kW	G3F-50-***-040	600, 750, 900, 1200	3	52	390	30	27	Ø15h6	5	17	2
0.75 kW	G3F-50-***-075	300, 375, 450	3	52.5	409.5	35	32	Ø20h6	6	22.5	11
1.5 kW	G3F-50-***-150	100, 120, 160, 200	4	51.5	362	40	35	Ø25h6	8	28	-
2.2 kW	G3F-50-***-220	30, 40, 50, 60, 80, 100	4	51.5	374	45	40	Ø30h6	8	33	-

Note: A reduction ratio will be indicated as *** in the nomenclature.
Note: Please refer to page 169 for the performance table.

G/G3 Type Parallel Shaft

H/H2 Type Right Angle Shaft

F Type Right Angle Hollow Bore/ Right Angle Shaft

F2/F3 Type Concentric Right Angle Hollow Bore/ Concentric Right Angle Shaft

Technical Documentation

G3 Type Parallel Shaft Shaft Diameter **18** **Small Flange Mounting**

<Figure 1>

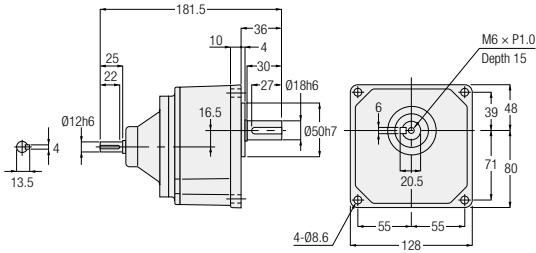

Power Class	Part Number	Reduction Ratio	Figure Number	Approx. Weight (kg)
0.1 kW	G3K-18-***-010	5, 10, 15, 20, 25, 30, 40, 50	1	3
0.2 kW	G3K-18-***-020	5, 10, 15, 20, 25	1	3

Note: A reduction ratio will be indicated as *** in the nomenclature.
 Note: Please refer to page 168 for the performance table.

G3 Type Parallel Shaft Shaft Diameter **22** **Small Flange Mounting**

<Figure 2>

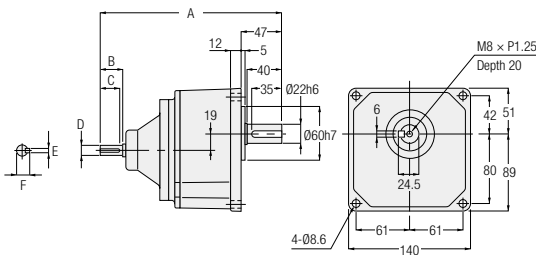

Power Class	Part Number	Reduction Ratio	Figure Number	Approx. Weight (kg)	A	B	C	D	E	F
0.1 kW	G3K-22-***-010	60, 80, 100, 120, 160, 200	2	4	207.5	25	22	Ø12h6	4	13.5
0.2 kW	G3K-22-***-020	30, 40, 50, 60, 80, 100	2	4	207.5	25	22	Ø12h6	4	13.5
0.4 kW	G3K-22-***-040	5, 10, 15, 20, 25	2	4.5	219	30	27	Ø15h6	5	17

Note: A reduction ratio will be indicated as *** in the nomenclature.
 Note: Please refer to page 168 for the performance table.

G3 Type Parallel Shaft Shaft Diameter **28** **Small Flange Mounting**

<Figure 1>

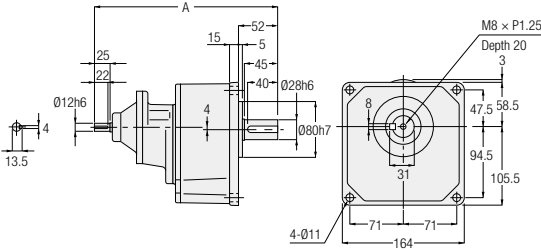

<Figure 2>

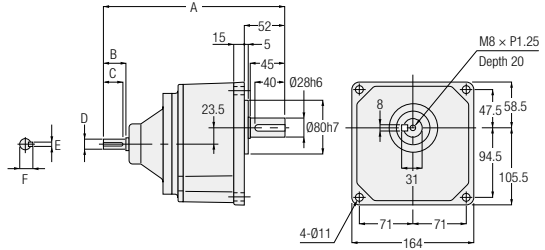

Power Class	Part Number	Reduction Ratio	Figure Number	Approx. Weight (kg)	A	B	C	D	E	F
0.1 kW	G3K-28-***-010	300, 375, 450	1	7	276.5	-	-	-	-	-
0.2 kW	G3K-28-***-020	100, 120, 160, 200	2	6	220.5	25	22	Ø12h6	4	13.5
0.4 kW	G3K-28-***-040	30, 40, 50, 60, 80, 100	2	6.5	235	30	27	Ø15h6	5	17
0.75 kW	G3K-28-***-075	5, 10, 15, 20, 25	2	6.5	244.5	35	32	Ø20h6	6	22.5

Note: A reduction ratio will be indicated as *** in the nomenclature.
 Note: Please refer to page 168 for the performance table.

G3 Type Parallel Shaft Shaft Diameter **32** **Small Flange Mounting**

<Figure 3>

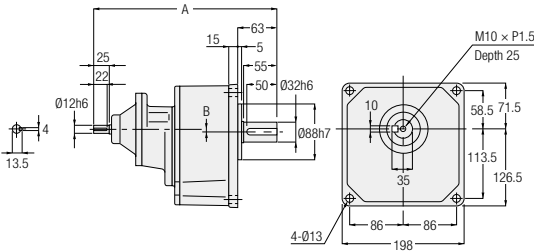

<Figure 4>

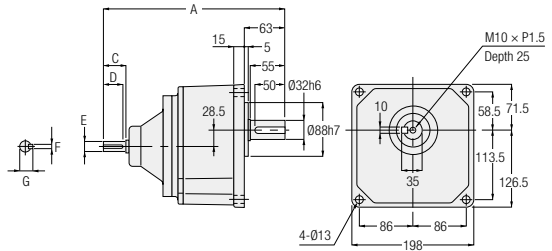

Power Class	Part Number	Reduction Ratio	Figure Number	Approx. Weight (kg)	A	B	C	D	E	F	G
0.1 kW	G3K-32-***-010	600, 750, 900, 1200	3	10	295.5	-1	-	-	-	-	-
0.2 kW	G3K-32-***-020	300, 375, 450	3	10	315.5	5.5	-	-	-	-	-
0.4 kW	G3K-32-***-040	100, 120, 160, 200	4	9.5	254	-	30	27	Ø15h6	5	17
0.75 kW	G3K-32-***-075	30, 40, 50, 60, 80, 100	4	10	273.5	-	35	32	Ø20h6	6	22.5
1.5 kW	G3K-32-***-150	5, 10, 15, 20, 25	4	10.5	297	-	40	35	Ø25h6	8	28

Note: A reduction ratio will be indicated as *** in the nomenclature.
 Note: Please refer to page 168 for the performance table.

G/G3 Type Parallel Shaft

H/H2 Type Right Angle Shaft

F Type Right Angle Hollow Bore/ Right Angle Shaft

F2/F3 Type Concentric Right Angle Hollow Bore/ Concentric Right Angle Shaft

Technical Documentation

6. S-Type Reducers (Type That Can Be Equipped with Designated Motor)

6-1. Performance Table

G3 Type S-Type Reducers (Type which Can be Equipped with Designated Motor)

[Notes]

- The motor power class value is the value when a 4 pole motor is used.
- When using an output shaft for a motor other than a 4 pole motor, the value obtained by multiplying the torque by the torque correction coefficient shown on page 566 shall be the allowable output shaft torque at the rotation.
- Allowable output shaft O.H.L. is the value at the middle of the output shaft.
- For the rotational direction of the output shaft, please refer to the figure shown below.
- The “*” mark indicates a limited torque type. Please make sure to check the allowable output shaft torque in the performance table.

■ Rotational Direction Relationship

The rotational direction shown below with arrow illustrates the rotation relationship between the output shaft / input shaft and is no way illustrating limitations in rotational direction.

Power	Reduction Ratio
0.1 kW	1/5 to 1/50 and 1/300 to 1/1200
0.2 kW, 0.4 kW	1/5 to 1/30 and 1/300 to 1/1200
0.75 kW	1/5 to 1/30 and 1/300 to 1/450
1.5 kW, 2.2 kW	1/5 to 1/30

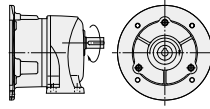

The input and output shafts rotate in the same direction.

Power	Reduction Ratio
0.1 kW	1/60 to 1/200
0.2 kW, 0.4 kW	1/40 to 1/200
0.75 kW, 1.5 kW	1/40 to 1/200
2.2 kW	1/40 to 1/100

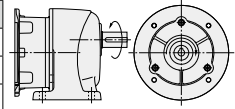

The input and output shafts rotate in the opposite directions.

4 Poles Motor Power Class	Frame Size	Reduction Ratio	Actual Reduction Ratio	Allowable Output Shaft Torque		Allowable Output Shaft O.H.L. N	Drawings		
				N-m			Foot Mount	Flange Mount	Small Flange Mount
				50 Hz	60 Hz				
0.1 kW	18	1/5	33/164	3	2.5	770	P.180	P.185	P.188
		1/10	77/779	6.1	5	1140			
		1/15	119/1804	9.1	7.5	1270			
		1/20	49/984	12	9.8	1530			
		1/25	28/697	15	12.7	1650			
		1/30	35/1066	19	14.7	1780			
	22	1/40	35/1404	24	19.6	1910	P.180	P.185	P.189
		1/50	7/351	29	24.5	2040			
		1/60	11/684	35	29.4	2800			
		1/80	21/1634	47	39.2	3180			
		1/100	7/684	59	49	3180			
		1/120	147/17974	71	58.8	3180			
	28	1/160	21/3268	94	78.4	3180	P.181	P.186	P.190
		1/200	21/4085	117	98	3180			
		1/300	221/65190	157	130	3430			
		1/375	187/68370	196	163	3430			
		1/450	1183/521520	235	196	3430			
		1/600	147/88192	313	261	5880			
32	1/750	49/36464	391	326	5880	P.182	P.187	P.191	
	* 1/900	62/57063	431	391	5880				
	* 1/1200	46/55195	431	431	5880				
0.2 kW	18	1/5	33/164	6.1	5	770	P.180	P.185	P.188
		1/10	77/779	11.8	9.8	1140			
		1/15	119/1804	18.6	14.7	1270			
		1/20	49/984	24.5	20.6	1450			
		1/25	28/697	30.4	25.5	1550			
		1/30	7/216	36.3	30.4	2280			
	22	1/40	91/3600	47	39.2	2410	P.180	P.185	P.189
		1/50	11/540	58.8	49	2540			
		1/60	637/39600	70.6	58.8	2800			
		1/80	91/7200	94.1	78.4	3000			
		* 1/100	11/1080	97	80.4	3180			
		1/100	13/1353	117	98	3690			
	28	1/120	91/11000	140	117	4320	P.181	P.186	P.190
		1/160	1/165	187	156	4450			
		1/200	7/1375	234	195	4450			
		1/300	91/27348	313	261	5880			
		1/375	77/28620	391	326	5880			
		1/450	91/41022	431	391	5880			
	32	1/600	9/5300	626	521	7060	P.182	P.187	P.191
		* 1/750	62/46427	764	653	7060			
		* 1/900	23/21259	764	764	7060			
		* 1/1200	9/10600	764	764	7060			

G/G3 Type Parallel Shaft

H/H2 Type Right Angle Shaft

F Type Right Angle Hollow Bore/ Right Angle Shaft

F2/F3 Type Concentric Right Angle Hollow Bore/ Concentric Right Angle Shaft

Technical Documentation

6-1. Performance Table

4 Poles Motor Power Class	Frame Size	Reduction Ratio	Actual Reduction Ratio	Allowable Output Shaft Torque		Allowable Output Shaft O.H.L. N	Drawings				
				N-m			Foot Mount	Flange Mount	Small Flange Mount		
				50 Hz	60 Hz						
0.4 kW	22	1/5	7/34	12	10	1140	P.180	P.185	P.189		
		1/10	7/68	25	21	1530					
		1/15	49/748	36	30	1780					
		1/20	7/136	48	40	1910					
		1/25	7/170	61	50	2050					
	28	1/30	1/30	73	61	3310	P.181	P.186	P.190		
		1/40	221/8610	94	78	3690					
		1/50	187/9030	117	98	4080					
		1/60	169/9840	140	117	4450					
		1/80	65/5166	187	156	4450					
		* 1/100	55/5418	193	161	4450					
		1/100	7/688	234	195	6370					
	32	1/120	77/9360	281	234	7640	P.182	P.187	P.191		
		1/160	21/3328	374	313	7640					
		1/200	189/38272	431	390	7640					
		1/300	7/2160	626	521	7060					
	40	* 1/375	77/29328	764	653	7060	P.183	P.187	-		
		* 1/450	49/21600	764	764	7060					
		* 1/600	57/35360	1225	1044	9800					
	50	* 1/750	25/19448	1225	1225	9800	P.184	P.188	-		
* 1/900		5/4338	1225	1225	9800						
* 1/1200		33/40664	1225	1225	9800						
1/5		91/459	23	19	1650	P.181				P.186	P.190
1/10		1/10	45	38	2280						
1/15	91/1360	68	57	2800							
1/20	5/102	91	75	3050							
1/25	7/170	114	94	3180							
0.75 kW	28	1/30	3/92	136	114	5220	P.182	P.187	P.191		
		1/40	13/516	175	146	5470					
		1/50	11/540	220	183	5780					
		1/60	13/774	264	220	6080					
		1/80	13/1032	351	293	6180					
	32	* 1/100	11/1080	362	302	6770	P.183	P.187	-		
		1/100	91/9000	439	366	9170					
		1/120	77/9400	527	439	9170					
		1/160	9/1400	703	585	9170					
		1/200	9/1750	764	732	9170					
40	1/300	211/62013	1176	978	9800	P.184	P.188	-			
	* 1/375	94/36103	1225	1225	9800						
	* 1/450	65/29167	1225	1225	9800						
1.5 kW	32	1/5	1/5	45	38	2280	P.182	P.187	P.191		
		1/10	1/10	91	75	3180					
		1/15	1/15	136	114	3690					
		1/20	1/20	181	151	4190					
		1/25	9/230	226	189	4410					
	40	1/30	1/30	272	226	6600	P.183	P.187	-		
		1/40	13/540	351	293	6960					
		1/50	11/564	439	366	6960					
		1/60	91/5400	527	439	7210					
		1/80	13/1080	703	585	7400					
		* 1/100	11/1128	724	603	7400					
		1/100	25/2618	878	732	12500					
	50	1/120	77/8993	1060	878	12500	P.184	P.188	-		
		* 1/160	33/5474	1230	1170	12500					
		* 1/200	30/5831	1230	1230	12500					
1/5		7/36	67	56	2800	P.183				P.187	-
1/10		7/72	133	111	4080						
1/15	49/720	200	167	4580							
1/20	7/144	266	221	5220							
1/25	7/180	332	277	6110							
1/30	5/154	399	332	9040							
1/40	399/15488	515	429	9420							
2.2 kW	40	1/50	399/20240	644	537	10000	P.184	P.188	-		
		1/60	49/2904	773	644	10000					
		1/80	49/3795	1029	858	10100					
	50	* 1/100	21/2116	1230	1080	10100	P.184	P.188	-		

G/G3 Type Parallel Shaft

H/H2 Type Right Angle Shaft

F Type Right Angle Hollow Bore/ Right Angle Shaft

F2/F3 Type Concentric Right Angle Hollow Bore/ Concentric Right Angle Shaft

Technical Documentation

6-2. Drawings

G3 Type Parallel Shaft Shaft Diameter **18** **Foot Mounting**

<Figure 1>

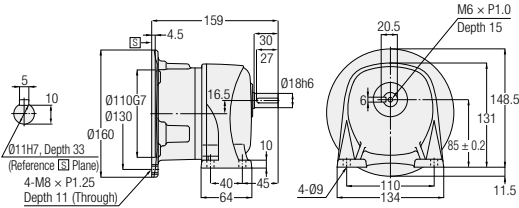

Power Class	Part Number	Reduction Ratio	Figure Number	Approx. Weight (kg)
0.1 kW	G3LS-18-***-010	5, 10, 15, 20, 25, 30, 40, 50	1	3.5
0.2 kW	G3LS-18-***-020	5, 10, 15, 20, 25	1	3.5

Note: A reduction ratio will be indicated as *** in the nomenclature.
 Note: Please refer to page 178 for the performance table.
 Note: Please refer to page 568 for the details of the motor mounting area.

G3 Type Parallel Shaft Shaft Diameter **22** **Foot Mounting**

<Figure 2>

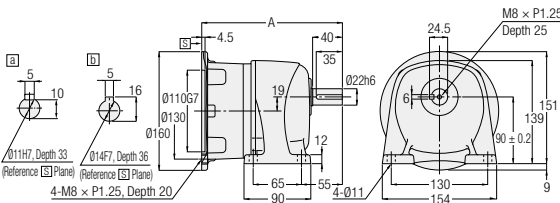

Power Class	Part Number	Reduction Ratio	Input Shaft	Figure Number	Approx. Weight (kg)	A	B
0.1 kW	G3LS-22-***-010	60, 80, 100, 120, 160, 200	a	2	4.5	185	11 (Through)
0.2 kW	G3LS-22-***-020	30, 40, 50, 60, 80, 100	a	2	4.5	185	11 (Through)
0.4 kW	G3LS-22-***-040	5, 10, 15, 20, 25	b	2	5	189.5	20

Note: A reduction ratio will be indicated as *** in the nomenclature.
 Note: Please refer to page 178 for the performance table.
 Note: Please refer to page 568 for the details of the motor mounting area.

G3 Type Parallel Shaft Shaft Diameter **28** Foot Mounting

<Figure 1>

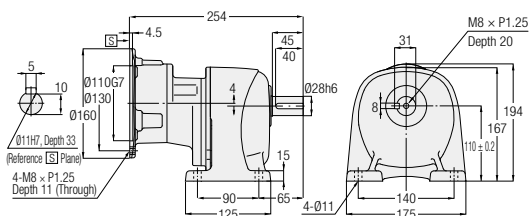

<Figure 2>

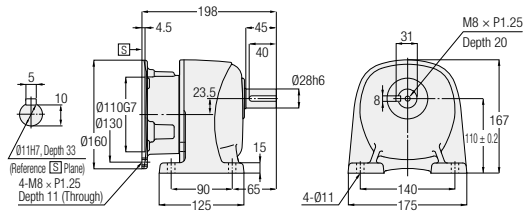

<Figure 3>

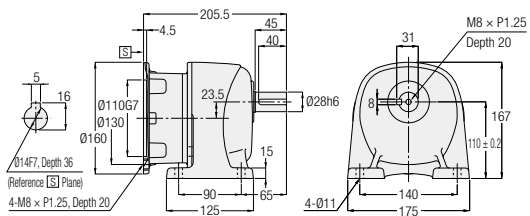

<Figure 4>

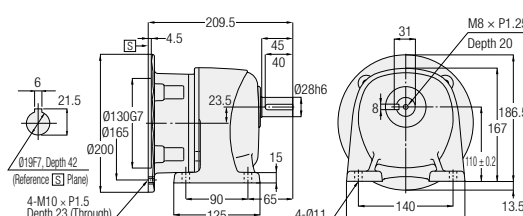

Power Class	Part Number	Reduction Ratio	Figure Number	Approx. Weight (kg)
0.1 kW	G3LS-28-***-010	300, 375, 450	1	7.5
0.2 kW	G3LS-28-***-020	100, 120, 160, 200	2	6.5
0.4 kW	G3LS-28-***-040	30, 40, 50, 60, 80, 100	3	7
0.75 kW	G3LS-28-***-075	5, 10, 15, 20, 25	4	6.5

Note: A reduction ratio will be indicated as *** in the nomenclature.
 Note: Please refer to page 178 for the performance table.
 Note: Please refer to page 568 for the details of the motor mounting area.

G/G3 Type Parallel Shaft

H/H2 Type Right Angle Shaft

F Type Right Angle Hollow Bore/Right Angle Shaft

F2/F3 Type Concentric Right-Angle Hollow Bore/Concentric Right Angle Shaft

Technical Documentation

G3 Type Parallel Shaft Shaft Diameter **32** **Foot Mounting**

<Figure 1>

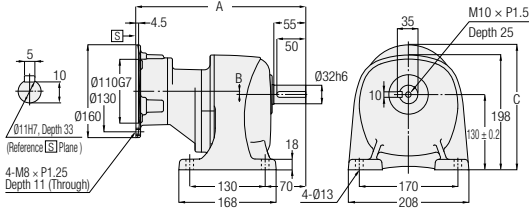

<Figure 2>

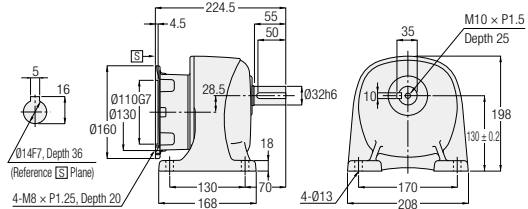

<Figure 3>

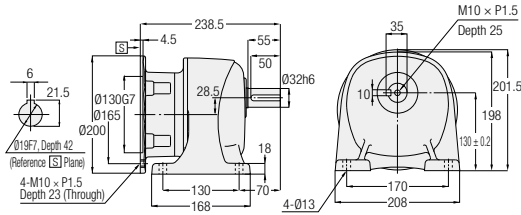

<Figure 4>

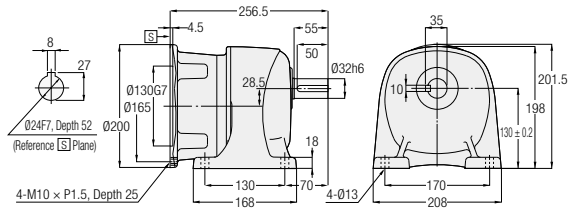

Power Class	Part Number	Reduction Ratio	Figure Number	Approx. Weight (kg)	A	B	C
0.1 kW	G3LS-32-***-010	600, 750, 900, 1200	1	10.5	273	-1	209
0.2 kW	G3LS-32-***-020	300, 375, 450	1	10.5	293	5.5	215.5
0.4 kW	G3LS-32-***-040	100, 120, 160, 200	2	10	-	-	-
0.75 kW	G3LS-32-***-075	30, 40, 50, 60, 80, 100	3	10	-	-	-
1.5 kW	G3LS-32-***-150	5, 10, 15, 20, 25	4	11.5	-	-	-

Note: A reduction ratio will be indicated as *** in the nomenclature.
 Note: Please refer to page 178 for the performance table.
 Note: Please refer to page 568 for the details of the motor mounting area.

G3 Type Parallel Shaft Shaft Diameter **40** Foot Mounting

<Figure 1>

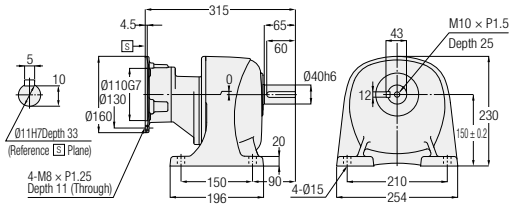

<Figure 2>

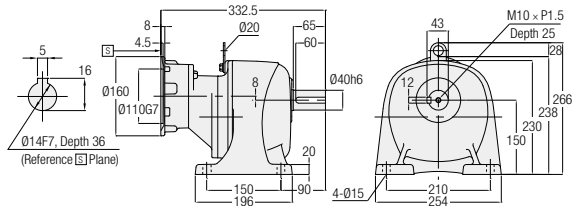

<Figure 3>

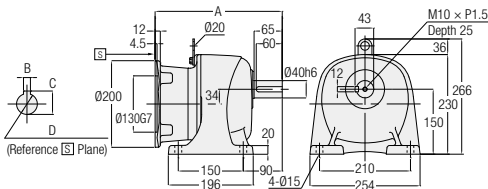

<Figure 4>

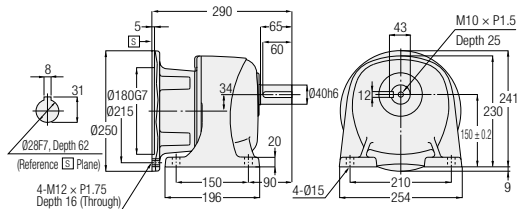

Note: Gearmotors with a motor power of 0.75 kW does not include the hanging plate.

Power Class	Part Number	Reduction Ratio	Figure Number	Approx. Weight (kg)	A	B	C	D
0.2 kW	G3LS-40-***-020	600, 750, 900, 1200	1	17	-	-	-	-
0.4 kW	G3LS-40-***-040	300, 375, 450	2	18.5	-	-	-	-
0.75 kW	G3LS-40-***-075	100, 120, 160, 200	3	16.5	260.5	6	21.5	Ø19F7, Depth 42
1.5 kW	G3LS-40-***-150	30, 40, 50, 60, 80, 100	3	18.5	293.5	8	27	Ø24F7, Depth 52
2.2 kW	G3LS-40-***-220	5, 10, 15, 20, 25	4	18	-	-	-	-

Note: A reduction ratio will be indicated as *** in the nomenclature.
 Note: Please refer to page 178 for the performance table.
 Note: Please refer to page 568 for the details of the motor mounting area.

G/G3 Type Parallel Shaft

H/H2 Type Right Angle Shaft

F Type Right Angle Hollow Bore/ Right Angle Shaft

F2/F3 Type Concentric Right-Angle Hollow Bore/ Concentric Right Angle Shaft

Technical Documentation

G3 Type Parallel Shaft Shaft Diameter **50** **Foot Mounting**

<Figure 1>

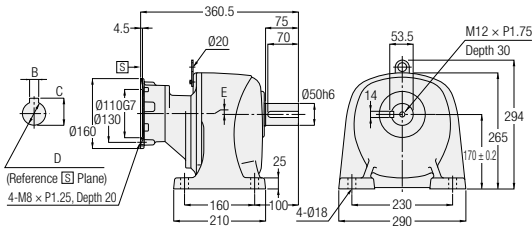

<Figure 2>

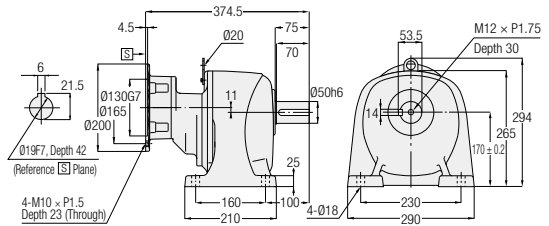

<Figure 3>

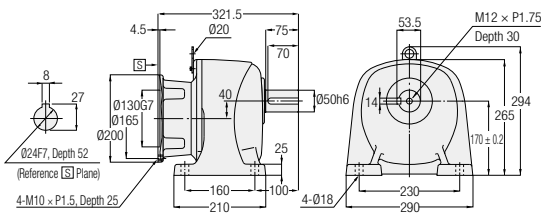

<Figure 4>

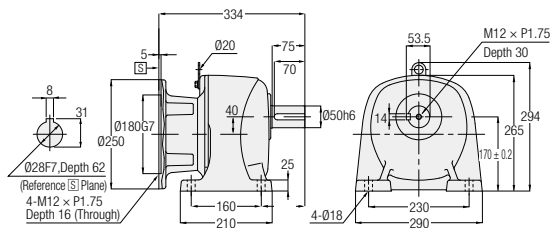

Power Class	Part Number	Reduction Ratio	Figure Number	Approx. Weight (kg)
0.4 kW	G3LS-50-***-040	600, 750, 900, 1200	1	48
0.75 kW	G3LS-50-***-075	300, 375, 450	2	48
1.5 kW	G3LS-50-***-150	100, 120, 160, 200	3	48
2.2 kW	G3LS-50-***-220	30, 40, 50, 60, 80, 100	4	48

Note: A reduction ratio will be indicated as *** in the nomenclature.
 Note: Please refer to page 179 for the performance table.
 Note: Please refer to page 568 for the details of the motor mounting area.

G3 Type Parallel Shaft Shaft Diameter **18** **Flange Mounting**

<Figure 1>

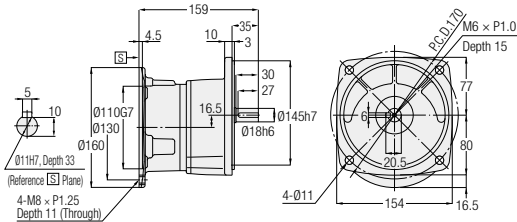

Power Class	Part Number	Reduction Ratio	Figure Number	Approx. Weight (kg)
0.1 kW	G3FS-18-***-010	5, 10, 15, 20, 25, 30, 40, 50	1	4
0.2 kW	G3FS-18-***-020	5, 10, 15, 20, 25	1	4

Note: A reduction ratio will be indicated as *** in the nomenclature.
 Note: Please refer to page 178 for the performance table.
 Note: Please refer to page 568 for the details of the motor mounting area.

G3 Type Parallel Shaft Shaft Diameter **22** **Flange Mounting**

<Figure 2>

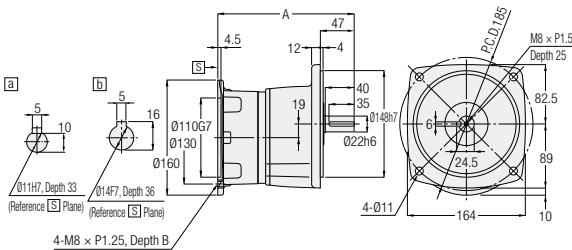

Power Class	Part Number	Reduction Ratio	Figure Number	Approx. Weight (kg)	Input Shaft	A	B
0.1 kW	G3FS-22-***-010	60, 80, 100, 120, 160, 200	2	5	a	185	11 (Through)
0.2 kW	G3FS-22-***-020	30, 40, 50, 60, 80, 100	2	5	a	185	11 (Through)
0.4 kW	G3FS-22-***-040	5, 10, 15, 20, 25	2	5.5	b	189.5	20

Note: A reduction ratio will be indicated as *** in the nomenclature.
 Note: Please refer to page 178 for the performance table.
 Note: Please refer to page 568 for the details of the motor mounting area.

G/G3 Type
Parallel Shaft

H/H2 Type
Right Angle Shaft

F Type
Right Angle Hollow Bore/
Right Angle Shaft

F2/F3 Type
Concentric Right Angle Hollow Bore/
Concentric Right Angle Shaft

Technical Documentation

G3 Type Parallel Shaft Shaft Diameter **28** **Flange Mounting**

<Figure 1>

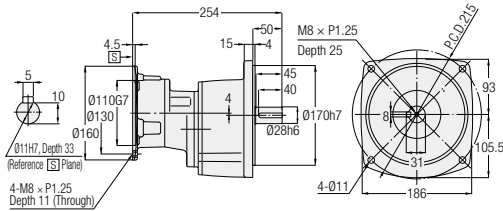

<Figure 2>

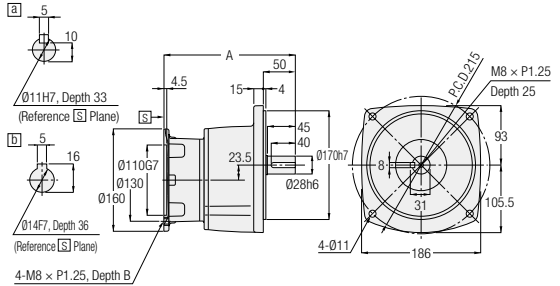

<Figure 3>

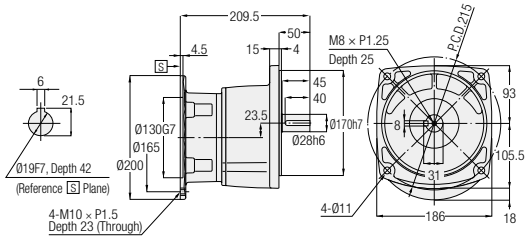

Power Class	Part Number	Reduction Ratio	Figure Number	Approx. Weight (kg)	Input Shaft	A	B
0.1 kW	G3FS-28-***-010	300, 375, 450	1	8	-	-	-
0.2 kW	G3FS-28-***-020	100, 120, 160, 200	2	7	a	198	11 (Through)
0.4 kW	G3FS-28-***-040	30, 40, 50, 60, 80, 100	2	7.5	b	205.5	20
0.75 kW	G3FS-28-***-075	5, 10, 15, 20, 25	3	7	-	-	-

Note: A reduction ratio will be indicated as *** in the nomenclature.
 Note: Please refer to page 178 for the performance table.
 Note: Please refer to page 568 for the details of the motor mounting area.

G3 Type Parallel Shaft Shaft Diameter **32** Flange Mounting

<Figure 1>

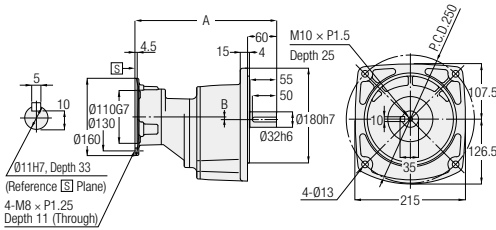

<Figure 2>

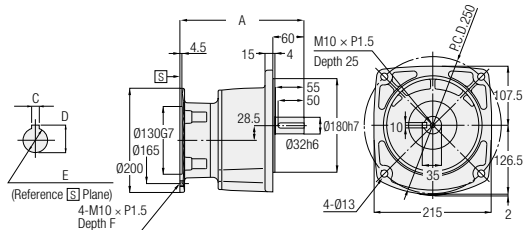

Power Class	Part Number	Reduction Ratio	Figure Number	Approx. Weight (kg)	A	B	C	D	E	F
0.1 kW	G3FS-32-***-010	600, 750, 900, 1200	1	11	273	-1	-	-	-	-
0.2 kW	G3FS-32-***-020	300, 375, 450	1	11	293	5.5	-	-	-	-
0.4 kW	G3FS-32-***-040	100, 120, 160, 200	2	10.5	224.5	-	5	16	Ø14F7, Depth 36	20
0.75 kW	G3FS-32-***-075	30, 40, 50, 60, 80, 100	2	10.5	238.5	-	6	21.5	Ø19F7, Depth 42	23 (Through)
1.5 kW	G3FS-32-***-150	5, 10, 15, 20, 25	2	11	256.5	-	8	27	Ø24F7, Depth 52	25

Note: A reduction ratio will be indicated as *** in the nomenclature.
 Note: Please refer to page 178 for the performance table.
 Note: Please refer to page 568 for the details of the motor mounting area.

G3 Type Parallel Shaft Shaft Diameter **40** Flange Mounting

<Figure 3>

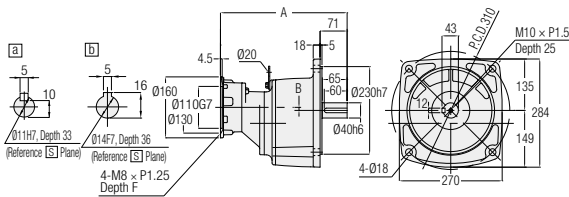

<Figure 4>

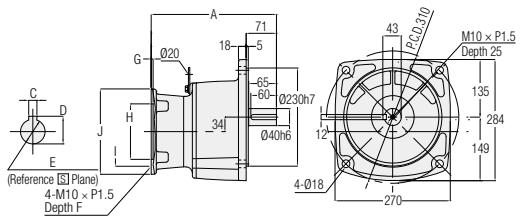

Note: Gearmotors with a motor power of 0.2 kW or 0.75 kW does not include the hanging plate.

Power Class	Part Number	Reduction Ratio	Figure Number	Approx. Weight (kg)	Input Shaft	A	B	C	D	E	F	G	H	I	J
0.2 kW	G3FS-40-***-020	600, 750, 900, 1200	3	18.5	a	315	0	-	-	-	11 (Through)	-	-	-	-
0.4 kW	G3FS-40-***-040	300, 375, 450	3	20	b	332.5	8	20	-	-	-	-	-	-	-
0.75 kW	G3FS-40-***-075	100, 120, 160, 200	4	18	-	260.5	-	6	21.5	Ø19F7, Depth 42	23 (Through)	4.5	130G7	165	200
1.5 kW	G3FS-40-***-150	30, 40, 50, 60, 80, 100	4	20	-	293.5	-	8	27	Ø24F7, Depth 52	25	4.5	130G7	165	200
2.2 kW	G3FS-40-***-220	5, 10, 15, 20, 25	4	19.5	-	290	-	8	31	Ø28F7, Depth 62	16 (Through)	5	130G7	215	250

Note: A reduction ratio will be indicated as *** in the nomenclature.
 Note: Please refer to page 178 for the performance table.
 Note: Please refer to page 568 for the details of the motor mounting area.

G3 Type Parallel Shaft Shaft Diameter **50** **Flange Mounting**

<Figure 1>

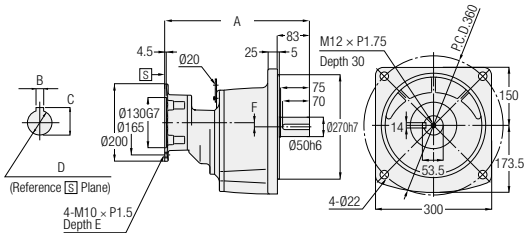

<Figure 2>

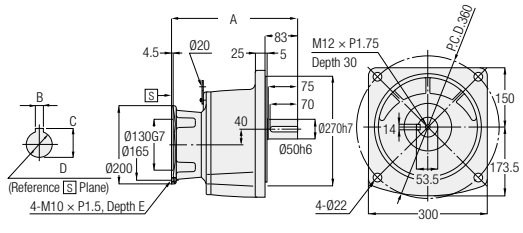

Power Class	Part Number	Reduction Ratio	Figure Number	Approx. Weight (kg)	A	B	C	D	E	F
0.4 kW	G3FS-50-***-040	600, 750, 900, 1200	1	53	360.5	5	16	Ø14F7, Depth 36	20	2
0.75 kW	G3FS-50-***-075	300, 375, 450	1	53	374.5	6	21.5	Ø19F7, Depth 42	23 (Through)	11
1.5 kW	G3FS-50-***-150	100, 120, 160, 200	2	53	321.5	8	27	Ø24F7, Depth 52	25	-
2.2 kW	G3FS-50-***-220	30, 40, 50, 60, 80, 100	2	53	334	8	31	Ø28F7, Depth 62	16 (Through)	-

Note: A reduction ratio will be indicated as *** in the nomenclature.
 Note: Please refer to page 179 for the performance table.
 Note: Please refer to page 568 for the details of the motor mounting area.

G3 Type Parallel Shaft Shaft Diameter **18** **Small Flange Mounting**

<Figure 3>

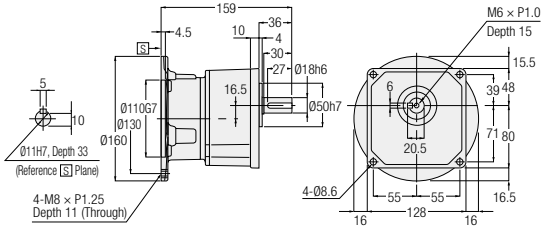

Power Class	Part Number	Reduction Ratio	Figure Number	Approx. Weight (kg)
0.1 kW	G3KS-18-***-010	5, 10, 15, 20, 25, 30, 40, 50	3	4
0.2 kW	G3KS-18-***-020	5, 10, 15, 20, 25	3	4

Note: A reduction ratio will be indicated as *** in the nomenclature.
 Note: Please refer to page 178 for the performance table.
 Note: Please refer to page 568 for the details of the motor mounting area.

G3 Type Parallel Shaft Shaft Diameter **28** **Small Flange Mounting**

<Figure 1>

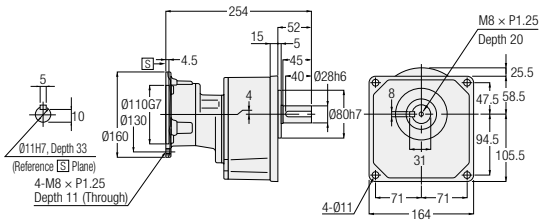

<Figure 2>

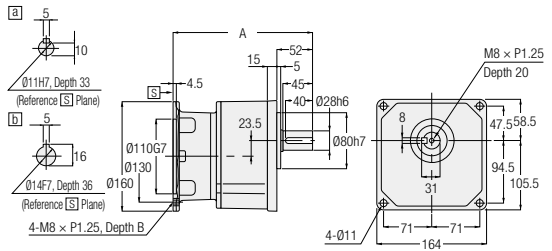

<Figure 3>

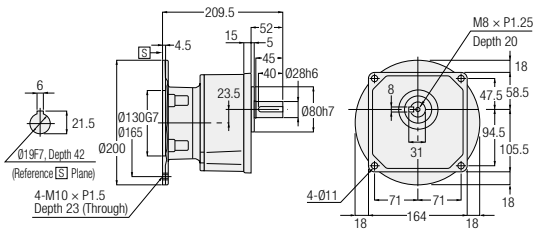

Power Class	Part Number	Reduction Ratio	Figure Number	Approx. Weight (kg)	Input Shaft	A	B
0.1 kW	G3KS-28-***-010	300, 375, 450	1	8	-	-	-
0.2 kW	G3KS-28-***-020	100, 120, 160, 200	2	7	a	198	11 (Through)
0.4 kW	G3KS-28-***-040	30, 40, 50, 60, 80, 100	2	7.5	b	205.5	20
0.75 kW	G3KS-28-***-075	5, 10, 15, 20, 25	3	7	-	-	-

Note: A reduction ratio will be indicated as *** in the nomenclature.
 Note: Please refer to page 178 for the performance table.
 Note: Please refer to page 568 for the details of the motor mounting area.

G3 Type Parallel Shaft Shaft Diameter **32** **Small Flange Mounting**

<Figure 1>

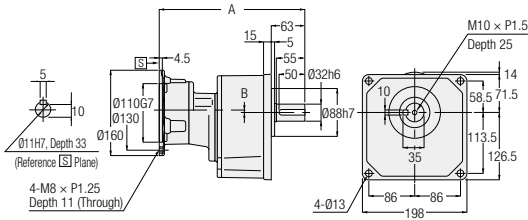

<Figure 2>

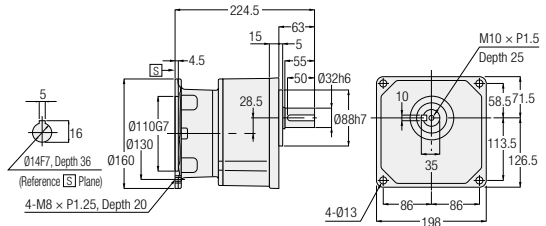

<Figure 3>

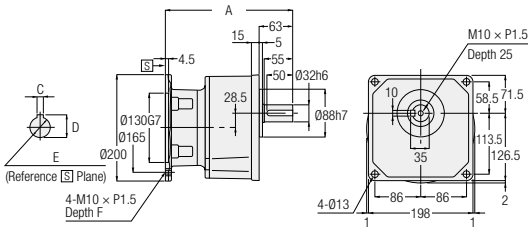

Power Class	Part Number	Reduction Ratio	Figure Number	Approx. Weight (kg)	A	B	C	D	E	F
0.1 kW	G3KS-32-***-010	600, 750, 900, 1200	1	11	273	-1	-	-	-	-
0.2 kW	G3KS-32-***-020	300, 375, 450	1	11	293	5.5	-	-	-	-
0.4 kW	G3KS-32-***-040	100, 120, 160, 200	2	10.5	-	-	-	-	-	-
0.75 kW	G3KS-32-***-075	30, 40, 50, 60, 80, 100	3	10.5	238.5	-	6	21.5	Ø19F7, Depth 42	23 (Through)
1.5 kW	G3KS-32-***-150	5, 10, 15, 20, 25	3	12	256.5	-	8	27	Ø24F7, Depth 52	25

Note: A reduction ratio will be indicated as *** in the nomenclature.
 Note: Please refer to page 178 for the performance table.
 Note: Please refer to page 568 for the details of the motor mounting area.

G/G3 Type Parallel Shaft

H/H2 Type Right Angle Shaft

F Type Right Angle Hollow Bore/Right Angle Shaft

F2/F3 Type Concentric Right Angle Hollow Bore/Concentric Right Angle Shaft

Technical Documentation

MEMO

G/G3 Type
Parallel Shaft

H/H2 Type
Right Angle Shaft

F Type
Right Angle Hollow Bore/
Right Angle Shaft

F2/F3 Type
Concentric Right Angle Hollow Bore/
Concentric Right Angle Shaft

Technical Documentation